

QUALITY • SERVICE • RANGE • VALUE

Stericut[®]

Product Catalogue

High performance blades and burs

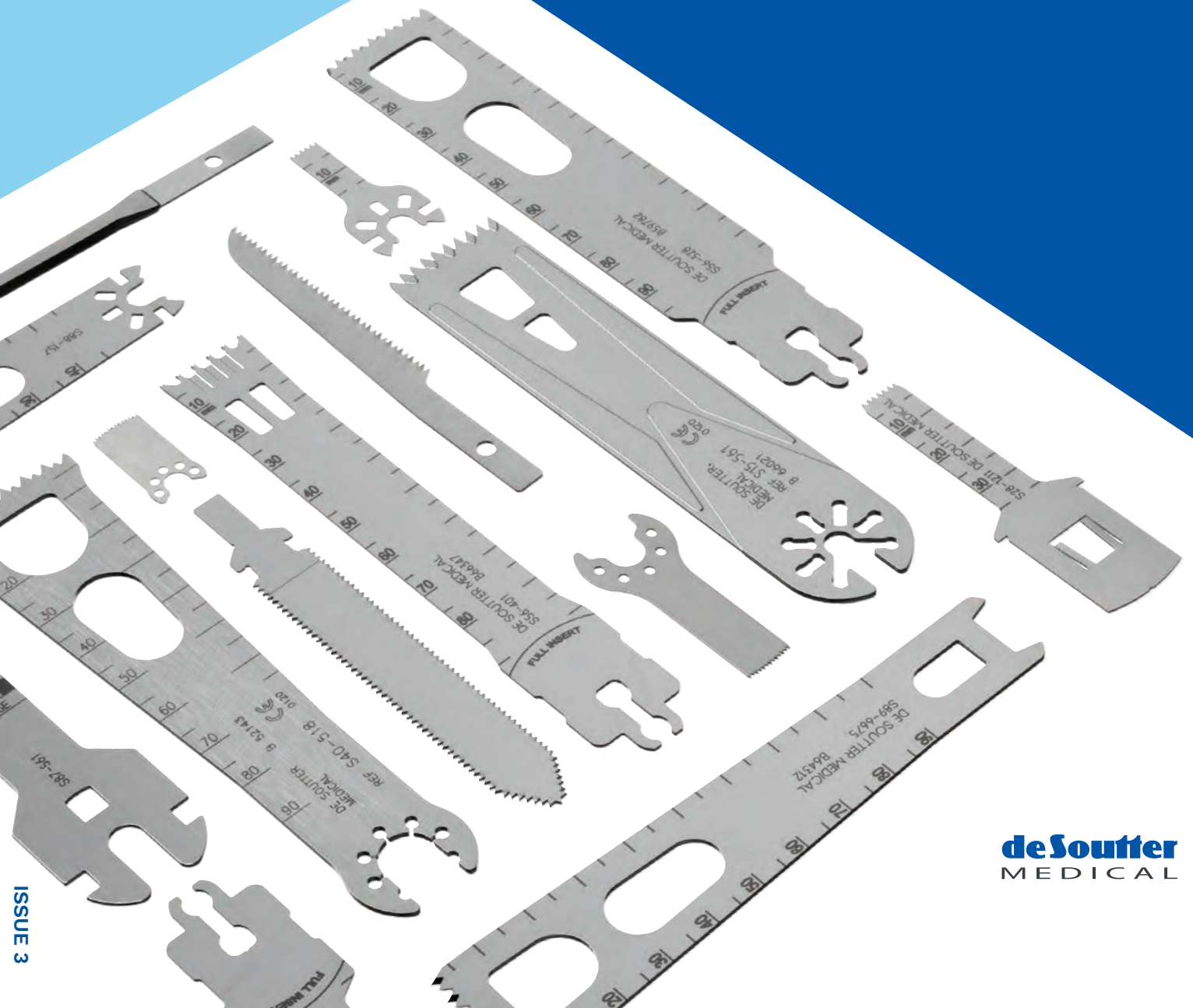

deSouther
MEDICAL



An Introduction to **Stericut®**

When you consider the cost of a surgical procedure and the importance of a “quality cut” to the bone, the decision to purchase a high-quality blade is in itself a cost saving.

Stericut® single-use saw blades, burs and drills are all manufactured by De Soutter Medical in the UK, at Tewkesbury, Gloucestershire. Our purpose-built factory has modern, state-of-the-art machinery installed to manufacture to the highest quality and provide sterile power tool consumables at competitive price levels.

Blades are manufactured using the latest CNC laser cutting and grinding machines. De Soutter Medical has over 65 years’ experience in the manufacture of powered instruments and its associated equipment giving our customers total confidence in the quality of our products.

Value Through Quality

When you consider the cost of a surgical procedure and the importance of a “quality cut” to the bone, the decision to purchase a high-quality blade is in itself a cost saving. For instance, poorly cut bone where a low quality blade inflicts





thermal necrosis, may be very costly in the long-term, leading to revisions. Also, some surgeons may identify that the blade is not cutting as it should and use two blades where one quality blade would suffice. De Soutter Medical therefore concentrates on a high-quality product which produces an optimum cutting edge to ensure a perfect cut even on the hardest of bone.

Service

De Soutter Medical currently has direct offices in the UK, Austria, Australia, Belgium, France, Germany, Italy, the Netherlands and U.S.A., as well as a comprehensive international distribution network across the rest of the world. In addition, we design and manufacture blades to customer specification whether that be an individual surgeon or companies such as implant manufacturers who require a specific blade design.

Our highly trained regional managers are always happy to come and see you to answer any questions you have and ensure you find the right product. We can provide you with samples to trial, if you are unsure of exactly what you need. Furthermore, our friendly and efficient customer service team are available to answer any questions about

De Soutter Medical products, both before and after their purchase, offering continuity of service throughout. Our customer service team is trained to troubleshoot and support customers on-site as required.

We understand the importance of on-time deliveries as most hospitals use a “just-in-time” approach to their consumable purchasing. Our standard delivery is next day for orders placed prior to 2 p.m., delivered before 5 p.m. the following day. Special deliveries are available for urgent orders, including same-day deliveries, and can be quoted as required.

Range

De Soutter Medical manufacture all of the blades for our wide range of power instruments, and in addition, we manufacture blades that are compatible with all other major power instrument manufacturers. As a specialist service we can, create a drawing from your specification for authorisation before taking to manufacture.



Blade Features

De Soutter Medical offer a comprehensive range of fully compatible saw blades for all current power tool systems.

These compatible blades are functionally equivalent both dimensionally and materially to the branded product that they've been designed to replace.

Compatibility with all current power tool systems on the market – around 50 hub options available.

Highest-grade surgical stainless steel is used. Consistent blade thickness increases overall cut accuracy due to a precise fit in the cutting jig.

De Soutter Medical's Precision Grinding Technology offers superior blade sharpness and sets a new standard for surgical blades.

Filleted edges along the blade length reduce soft tissue damage, and wear through cutting jigs.

A fully comprehensive range of tooth formations to match every possible procedure type.

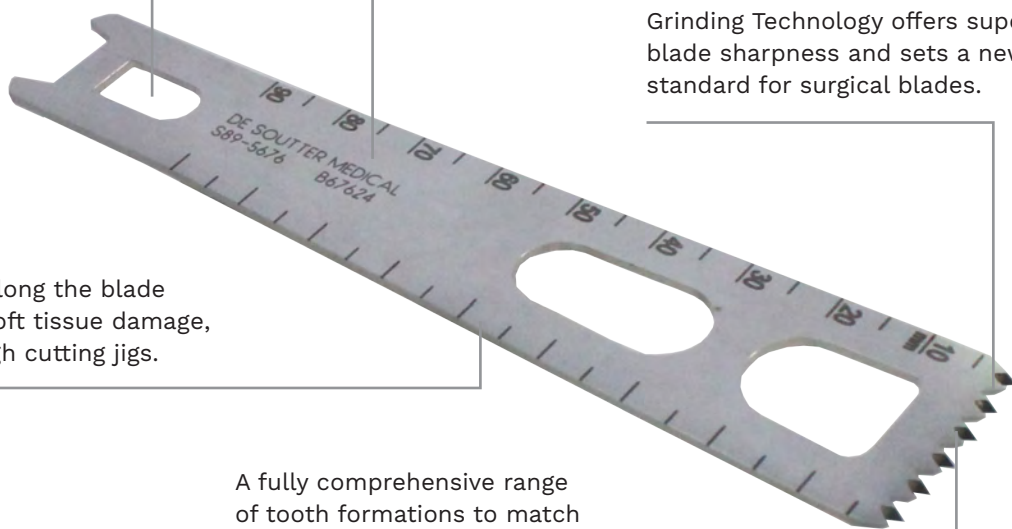

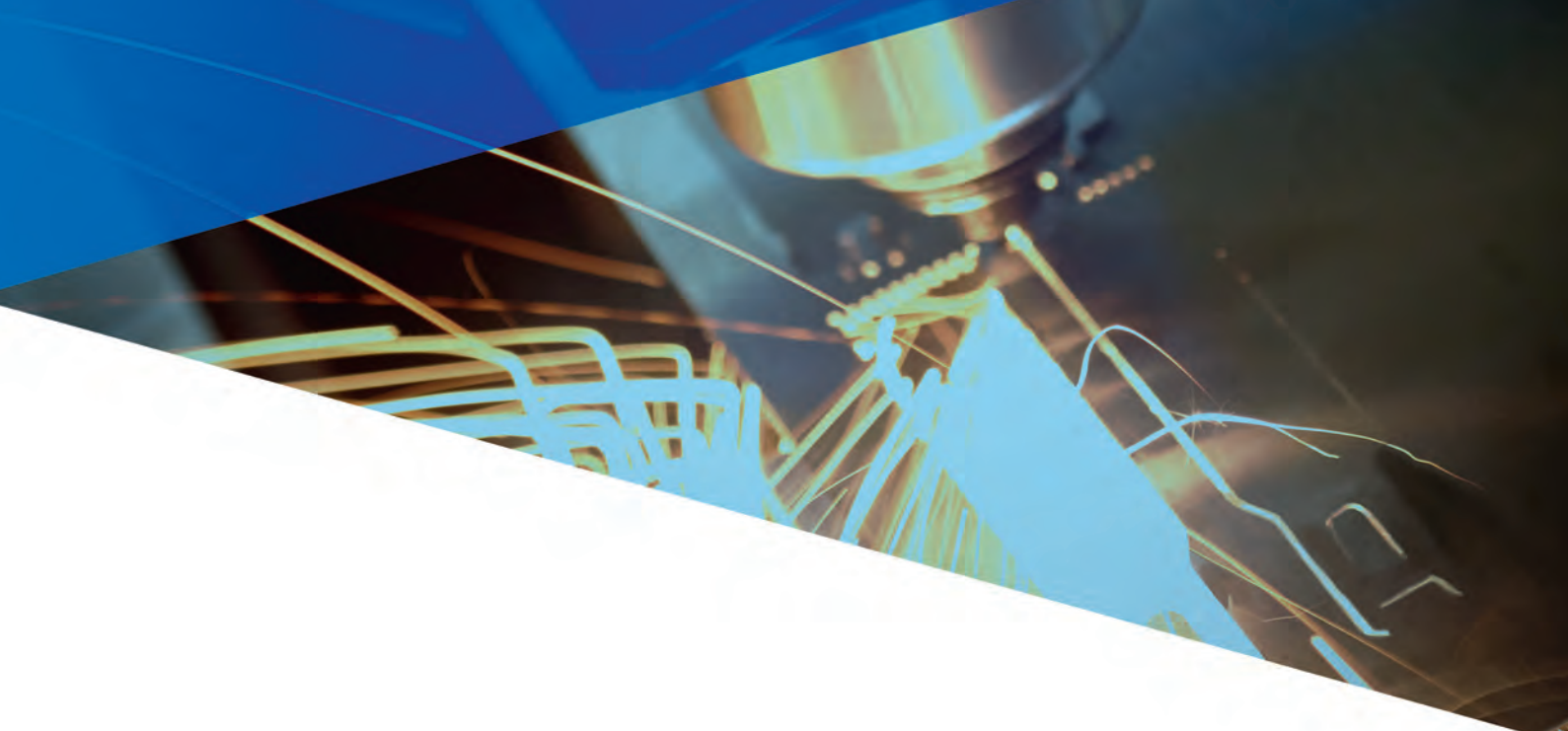

Quality Control

Our Stericut® range of products are supplied sterile double pouched, ready for operating theatre use. Our world-class clean room facility in the UK exceeds the requirements for BS EN ISO 14644-1 and ensures total confidence in the quality of product leaving our facility. We have regular microbiological sampling to monitor the performance of our contamination control systems.

The company is accredited to ISO 13485 quality standards and all our products and systems comply with the European Medical Devices Directive (93/42/EEC). All Stericut® products are recommended only for single-use and are suitably marked to ensure traceability.

Whilst De Soutter Medical clearly

recognise the importance of a technologically advanced product, we also believe that any product is only as good as the service which supports it. It is for this reason that we strive to provide high-quality customer service. Our goal is total customer satisfaction.



Glossary

Sagittal & Oscillating Blades

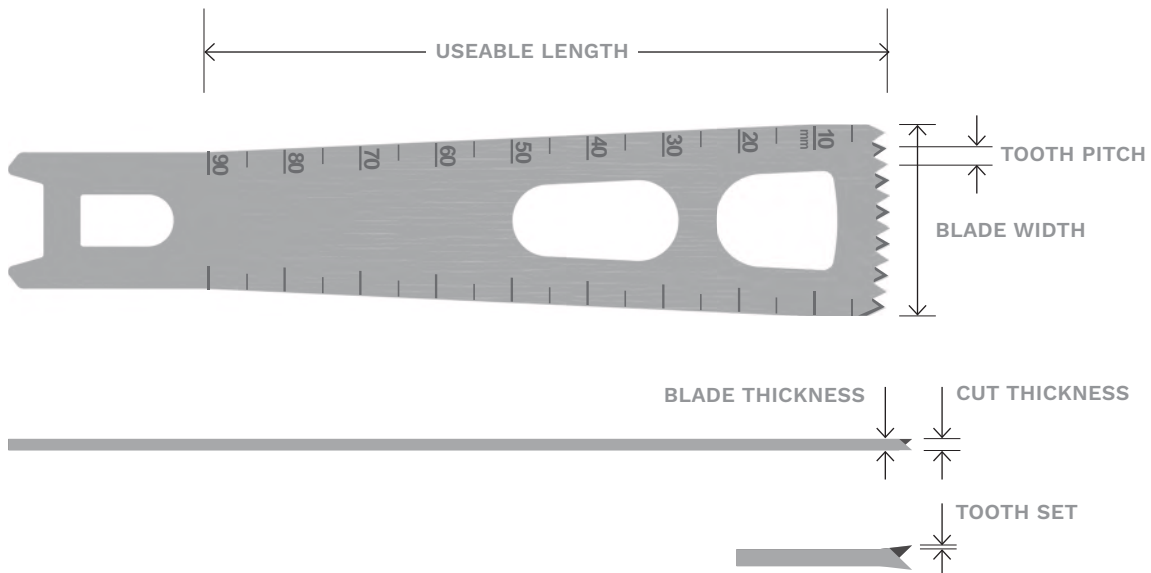

USEABLE LENGTH

The maximum depth of cut possible.

BLADE WIDTH

The width across the tooth form of the blade.

BLADE THICKNESS

The actual thickness of the blade material.

CUT THICKNESS

The distance across the tooth form. This can be greater than the blade thickness if there is a set on the teeth.

TOOTH SET

The difference between the blade and cut thicknesses. Tooth set allows for efficient bone debridement during cutting.

TOOTH PITCH

The distance between teeth on the cutting face. A smaller tooth pitch will produce a finer cut, a larger pitch will produce a coarser cut.

Tooth Formations



STANDARD

Conventional tooth formation for less aggressive cuts



OPPOSED

Teeth pointing in opposite directions improves blade stability



WEBLITE

Recessed blade surface, without tooth offset improves debris removal and reduces skiving



TWIN TOOTH

Twin tooth formation combined with debris removal channels ensures precise cuts



PRISMATIC

Prism shaped tooth formation gives knife edge sharpness for greater cutting efficiency



ULTRACUT

Zero offset prismatic tooth formation, combined with debris removal channels produces optimal cutting performance

Glossary

Reciprocating & Sternum Blades

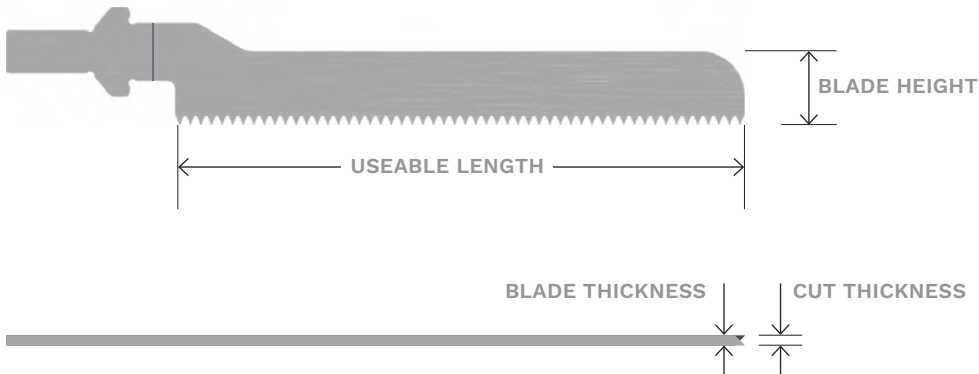

BLADE HEIGHT
The difference between the top of the blade and the tip of the teeth

USEABLE LENGTH
The length of the tooth form

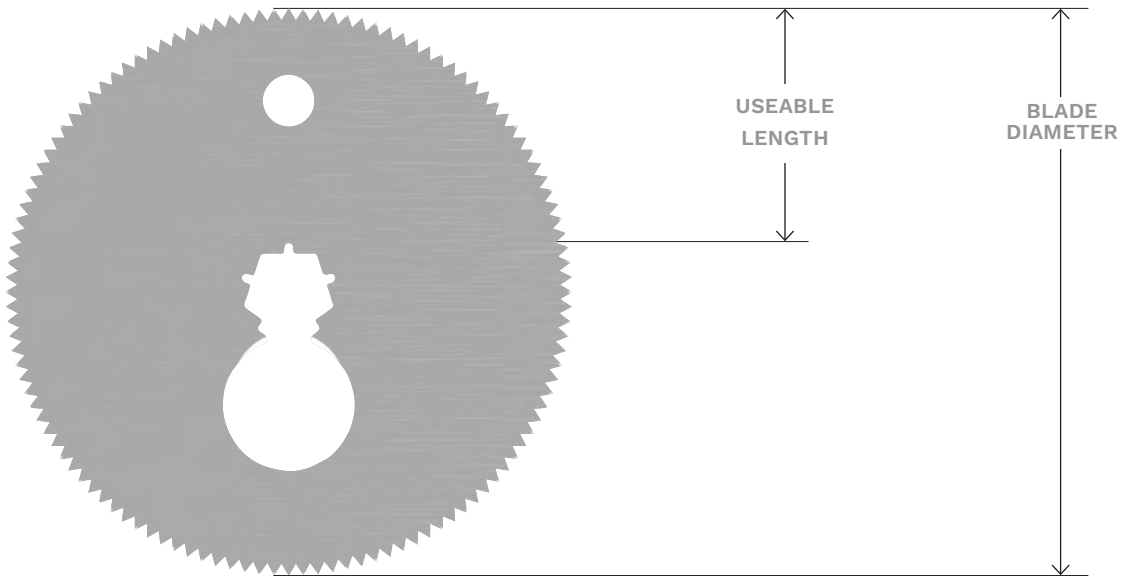

USEABLE LENGTH
The maximum depth of cut possible

BLADE DIAMETER
The total width of the blade

Catalogue Usage Guide

This catalogue is designed to help you find the blade you're after as quickly as possible. Divided into coloured sections according to the compatible manufacturer of the tool they fit, the blades are organised in numerical order within these sections.

Data Sections

At the beginning of each section is an introductory sheet showing the blade hubs featured within so you can easily find what you are looking for, as well as the tool type being listed alongside.

Within each manufacturer section the blades are arranged by number so each range is grouped together. This helps you to find the right blade quickly and alternative or additional blades for your tools easily.

The diagrams are actual size to aid with finding the right blade.

Reference

If you've got a reference number from another manufacturer, please consult our cross reference charts at the back of the catalogue. This will tell you our compatible part number.

	Linvatec®/Hall®
	Aesculap®
	Synthes®
	Stryker®
	Zimmer®
	Smith & Nephew® MicroAire® Arthrex® / Tuke™
	De Soutter Medical®
	Dermatome
	Drills / K Wires
	Reference

Order Information

Blades can be ordered easily using any of the methods below and are despatched on the day of order if ordered before 2.00pm GMT. See the back page for your local office.

Tel:+44 (0) 1296 634 000

Email: Orders@de-soutter.com

Delivery

UK Delivery

Delivery within the UK is next-day as standard if the order is received before 2.00pm.

Timed deliveries for before 10.30am, before 12 midday, and Saturday deliveries are available upon demand at additional cost. Same-day courier deliveries can also be arranged for urgent deliveries, from our headquarters in Buckinghamshire, transit times and costs will be quoted at time of request.

Rest of the World

Delivery times and costs using our couriers can be quoted upon receipt of an order. Alternatively, you may decide to make your own arrangements for collection of the goods.

Copyright Information

Aesculap® is a registered trademark of Aesculap AG & Co. KG.

Arthrex® is a registered trademark of Arthrex Inc.

Biomet® is a registered trademark of Biomet Inc.

Hall® is a registered trademark of ConMed Corporation.

Linvatec® is a registered trademark of ConMed Corporation.

MicroAire® is a registered trademark of MicroAire Surgical Instruments, LLC.

Smith & Nephew® (Formally Dyonics® Products) is a registered trademark of Smith & Nephew Inc.

Stryker® is a registered trademark of Stryker Corporation.

Synthes® is a registered trademark of Synthes-Stratec.

Tuke Saw™ is a trademark of MatOrtho.

Zimmer® is a registered trademark of Zimmer Inc.

Cordless Driver®, Hall 50®, MPower®, PowerPro®, Orthair®, Dyonics® Acculan®, are registered trademarks

CD4™, Sabo™, Tuke™, System 6™, System 7™, System 8™, Micro 100™, MicroPower™, MicroFree™, Mini-Driver™, Maxi-Driver™, ComPact™ Colibri™, Powerline™, TRS™, and Power System 300, Universal power™, are trademarks of Third Party Companies identified above.

De Soutter Medical are not associated with the above listed trademark owners and are owners of the Stericut® trademark only.

Data is correct at the time of publishing and is subject to change without notice.

Terms & Conditions of Sale

1. All cutting accessories in this catalogue manufactured by us are guaranteed for single use, unless otherwise specified, from the date of purchase from us or our agents against defective workmanship and materials, and goods proved to be defective during this period in these respects will be replaced or repaired free of charge.

In the case of goods merely supplied by but not manufactured by us we merely pass on the benefit of any guarantees, conditions, and warranties received by us in respect of such goods.

None of the previous statements in this paragraph affect customers statutory rights and such statements are in addition to such rights.

2. Every effort will be made to keep to the delivery dates, but no liability can be accepted for loss caused through delay for reasons beyond our control or by industrial dispute of any kind (whether involving any of our employees or not) or by any failure to obtain materials goods or equipment from a supplier through no fault of our own in due time to observe delivery dates. The right is reserved to suspend delivery as long as any payment for goods previously invoiced is in arrears.
3. In view of the fluctuations, raw material costs, etc., the prices quoted are subject to alteration without prior notice. Goods will be invoiced at prices ruling at date of despatch notwithstanding any quotation or prior acceptance of order.
4. Payment should be made in full within 30 days of invoice date unless other arrangements are settled.
5. All goods will remain our property until such time that the full invoice value has been paid.
6. Minimum order value is £50.00 or EUR 80.
7. Equipment may not be returned to us for credit without obtaining our prior written authorisation. All returned goods will be subject to a re-stocking charge.
8. All goods shall at all times be at buyers risk.
9. Post, carriage and packing will be charged extra in accordance with our published scale.
10. **Prices do not include V.A.T.** which will be charged extra as appropriate.
11. The applicable law shall be the law of England.
12. Whilst every reasonable care is taken to ensure that our products are safe, you are requested to pay particular attention to applying the proper health and safety precautions in the use of our products and where instruction manuals are issued, that the instructions therein are scrupulously observed.
13. The above terms and conditions shall apply notwithstanding customers terms and conditions and anything which may be stated or implied to the contrary in correspondence or other conditions.
14. Claims for shortages must be submitted in writing within 10 days from receipt of goods.
15. Goods returned for credit with seller's prior agreement will be subject to a standard re-stocking charge of 15% of the net invoiced value.

Conmed Linvatec® / Hall® Sterile Packed Compatible Blades

Sagittal
Saws

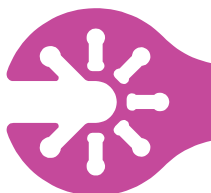

S15

Hall 50®
MPower2®
MPower®
PowerPro®



S18

MicroFree®
MicroPower+®
MicroPower®
Micro 100™



S18

MicroFree®
MicroPower™ +
MicroPower®
Micro 100™

Reciprocating
Saws



S22

Hall 50®
MPower2®
MPower®
PowerPro®



S22

MicroFree®
MicroPower+®
MicroPower®
Micro 100™

Sternum
Saws



S22

Hall 50®
MPower2®

All blades shown actual size (1:1). All measurements in mm.

Linvatec®, Hall®, Hall 50®, MicroPower+®, MicroPower®, Mpower®, PowerPro®, are registered trademarks and MicroFree®, Micro 100™ are trademarks of ConMed Corporation.

cm 1 2 3 4 5 6 7 8 9 10 11 12 13 14 15 16





Conmed Linvatec® / Hall® Sterile Packed Compatible Blades

Part No.	OEM Part No.	Useable Length	Blade Height/Width	Blade Thickness	Cut Thickness	Type
----------	--------------	----------------	--------------------	-----------------	---------------	------

S01-001	PROCEDURE PACK - 3 PACK - OXFORD CEMENTLESS - HALL® S22 & S15					
----------------	---	--	--	--	--	--



S22-381	-	15	14	2.93	2.93	CEMENTLESS
----------------	---	----	----	------	------	------------

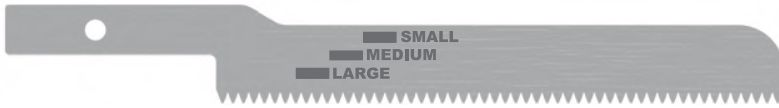

S22-364	-	76	10	1.00	1.20	-
----------------	---	----	----	------	------	---

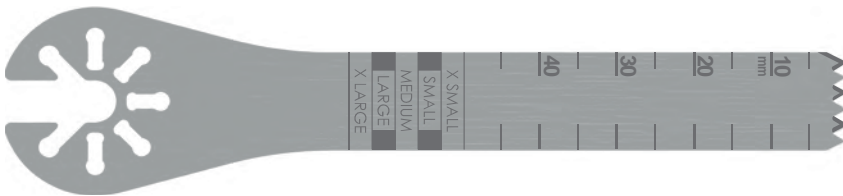

S15-562	-	85	13	0.89	0.89	-
----------------	---	----	----	------	------	---

All blades shown actual size (1:1). All measurements in mm.

Linvatec®, Hall®, Hall 50®, MicroPower+®, MicroPower®, Mpower®, PowerPro®, are registered trademarks and MicroFree®, Micro 100™ are trademarks of ConMed Corporation.

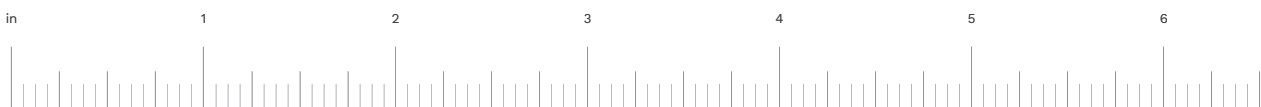

Conmed Linvatec® / Hall® Sterile Packed Compatible Blades

Part No.	OEM Part No.	Useable Length	Blade Width	Tooth Pitch	Blade Thickness	Cut Thickness
----------	--------------	----------------	-------------	-------------	-----------------	---------------

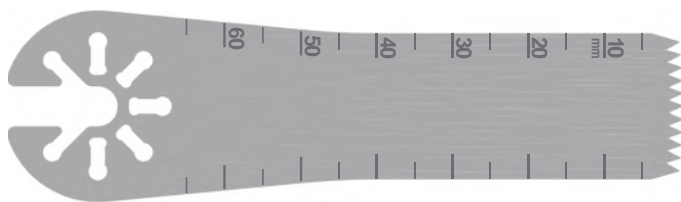

S15-102	5071-553	63	19.5	1.7	0.60	0.90
----------------	----------	----	------	-----	------	------



S15-103	5071-552	64	13.5	1.7	0.60	0.90
----------------	----------	----	------	-----	------	------

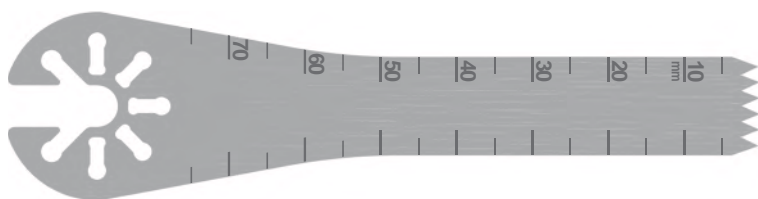

S15-105	5071-145	72	13	2.1	1.20	1.45
----------------	----------	----	----	-----	------	------

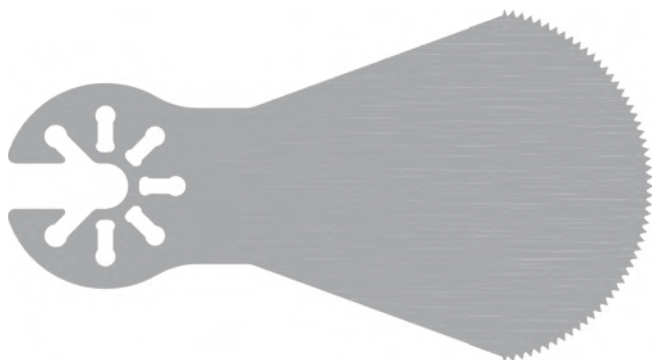

S15-125	-	54	44	1.1	0.60	1.00
----------------	---	----	----	-----	------	------

All blades shown actual size (1:1). All measurements in mm.

Linvatec®, Hall®, Hall 50®, MicroPower+®, MicroPower®, Mpower®, PowerPro®, are registered trademarks and MicroFree®, Micro 100™ are trademarks of ConMed Corporation.

cm 1 2 3 4 5 6 7 8 9 10 11 12 13 14 15 16



Conmed Linvatec® / Hall® Sterile Packed Compatible Blades

Part No.	OEM Part No.	Useable Length	Blade Width	Tooth Pitch	Blade Thickness	Cut Thickness
----------	--------------	----------------	-------------	-------------	-----------------	---------------

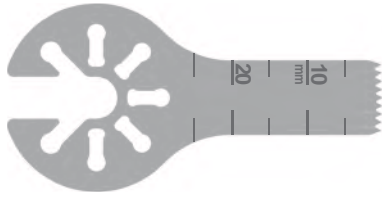

S15-133	5071-133	25.5	9.5	1.1	0.40	0.60
----------------	----------	------	-----	-----	------	------

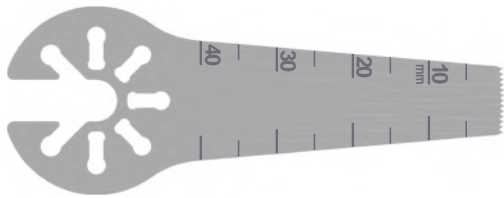

S15-134	5071-134	41	9	0.7	0.40	0.60
----------------	----------	----	---	-----	------	------

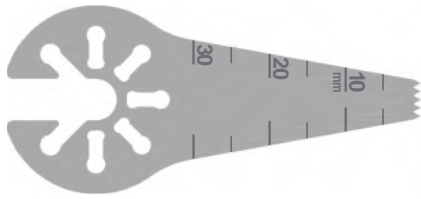

S15-135	5071-135	30	5	1.1	0.60	0.80
----------------	----------	----	---	-----	------	------

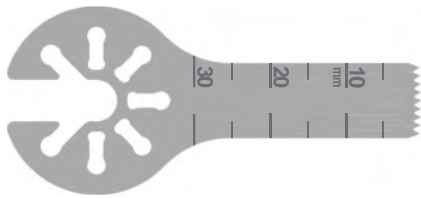

S15-171	5071-571	30	9.5	1.1	0.64	0.84
----------------	----------	----	-----	-----	------	------

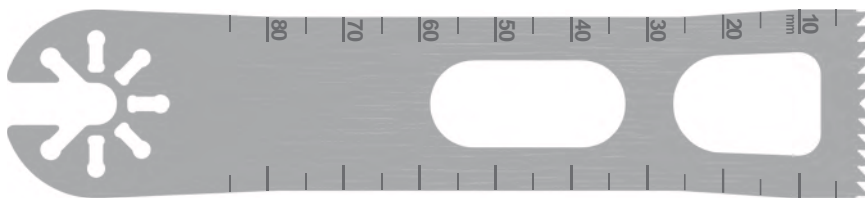

S15-200	5071-143	90	25.4	2.1	0.80	0.90
----------------	----------	----	------	-----	------	------

All blades shown actual size (1:1). All measurements in mm.

Linvatec®, Hall®, Hall 50®, MicroPower+®, MicroPower®, Mpower®, PowerPro®, are registered trademarks and MicroFree®, Micro 100™ are trademarks of ConMed Corporation.

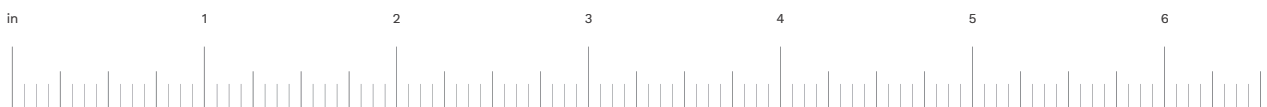

Conmed Linvatec® / Hall® Sterile Packed Compatible Blades

Part No.	OEM Part No.	Useable Length	Blade Width	Tooth Pitch	Blade Thickness	Cut Thickness
----------	--------------	----------------	-------------	-------------	-----------------	---------------

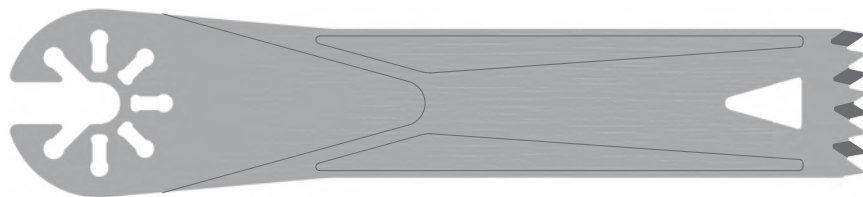

S15-201	5071-201	86	19.5	2.6	1.27	1.27
----------------	----------	----	------	-----	------	------

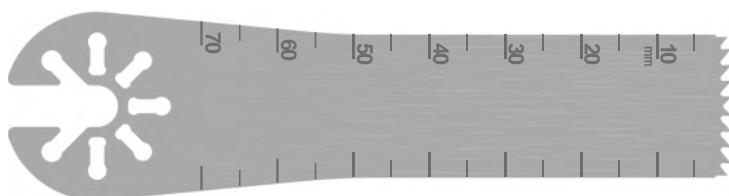

S15-202	-	71	19	2.1	0.80	0.80
----------------	---	----	----	-----	------	------

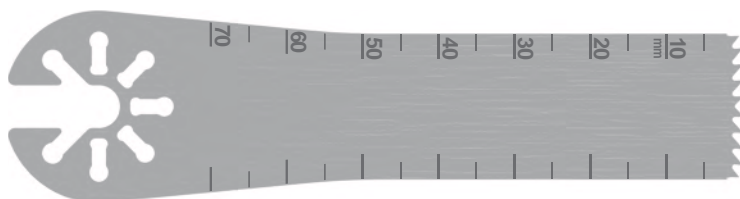

S15-203	5071-187	71	19.5	2.1	0.80	0.90
----------------	----------	----	------	-----	------	------

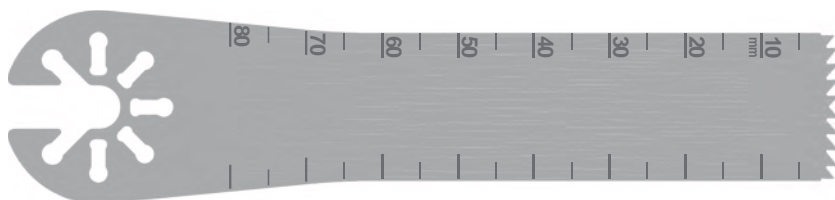

S15-204	5071-188	80	19.5	2.1	0.80	0.90
----------------	----------	----	------	-----	------	------

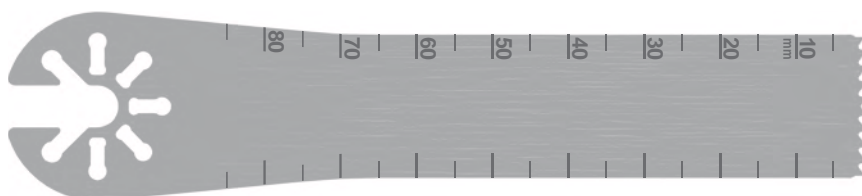

S15-205	5071-141	85	19.5	2.1	1.20	1.40
----------------	----------	----	------	-----	------	------

All blades shown actual size (1:1). All measurements in mm.

Linvatec®, Hall®, Hall 50®, MicroPower+®, MicroPower®, Mpower®, PowerPro®, are registered trademarks and MicroFree®, Micro 100™ are trademarks of ConMed Corporation.

cm 1 2 3 4 5 6 7 8 9 10 11 12 13 14 15 16



Conmed Linvatec® / Hall® Sterile Packed Compatible Blades

Part No.	OEM Part No.	Useable Length	Blade Width	Tooth Pitch	Blade Thickness	Cut Thickness
----------	--------------	----------------	-------------	-------------	-----------------	---------------

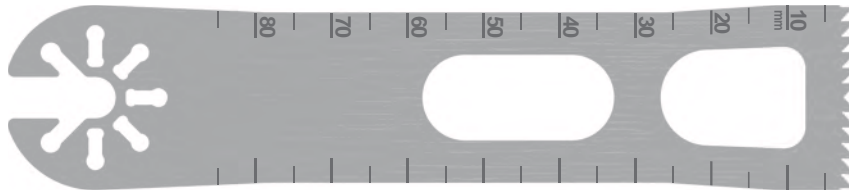

S15-206	5071-142	90	25.4	2.1	1.20	1.40
----------------	----------	----	------	-----	------	------

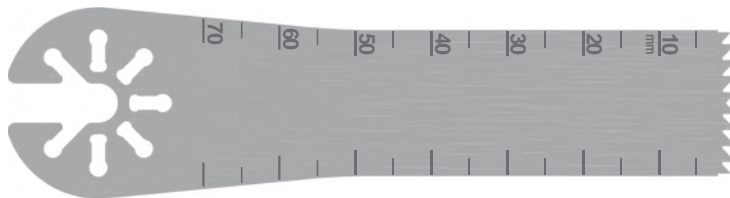

S15-207	5071-554	71	19.5	2.1	1.20	1.40
----------------	----------	----	------	-----	------	------

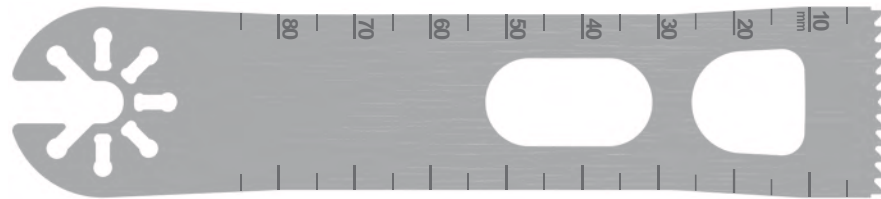

S15-209	-	90	25	2.1	1.47	1.47
----------------	---	----	----	-----	------	------

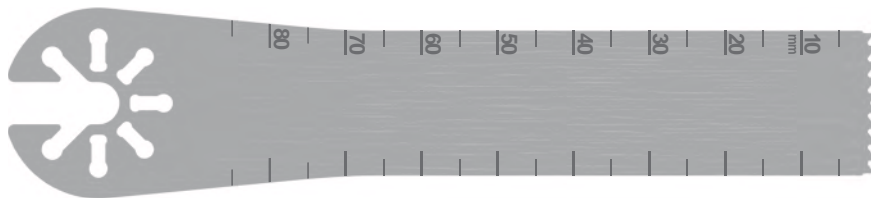

S15-215	-	90	19	2.1	1.00	1.20
----------------	---	----	----	-----	------	------

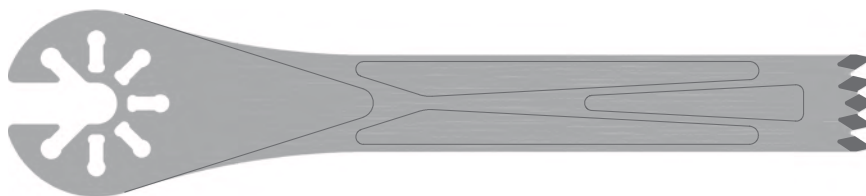

S15-220	5071-582	90	13	2.9	1.27	1.27
----------------	----------	----	----	-----	------	------

All blades shown actual size (1:1). All measurements in mm.

Linvatec®, Hall®, Hall 50®, MicroPower+®, MicroPower®, Mpower®, PowerPro®, are registered trademarks and MicroFree®, Micro 100™ are trademarks of ConMed Corporation.

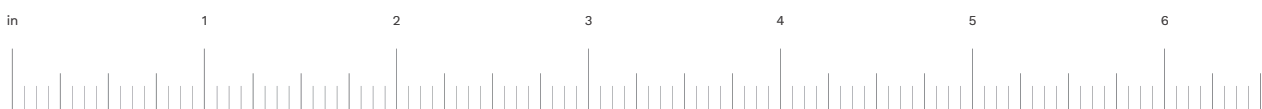

Conmed Linvatec® / Hall® Sterile Packed Compatible Blades

Part No.	OEM Part No.	Useable Length	Blade Width	Tooth Pitch	Blade Thickness	Cut Thickness
----------	--------------	----------------	-------------	-------------	-----------------	---------------

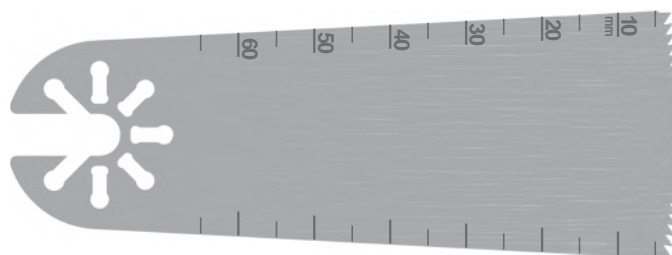

S15-256	-	65	33	1.4	0.80	0.95
----------------	---	----	----	-----	------	------

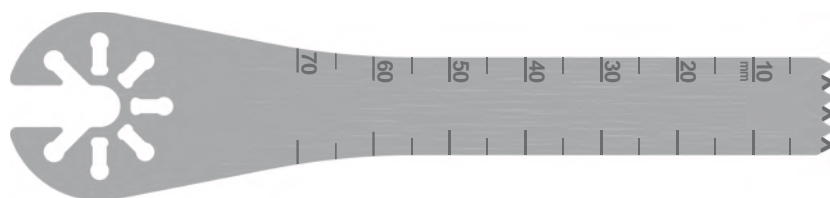

S15-501	-	85	13	2.1	1.19	1.27
----------------	---	----	----	-----	------	------

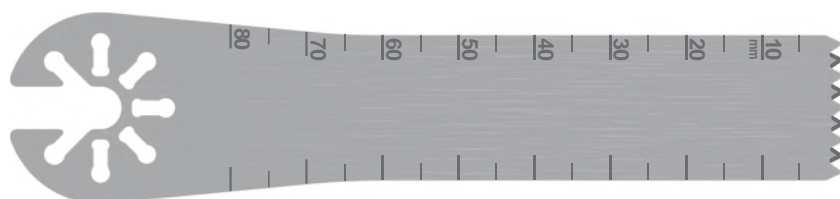

S15-503	-	85	19	2.1	1.19	1.27
----------------	---	----	----	-----	------	------

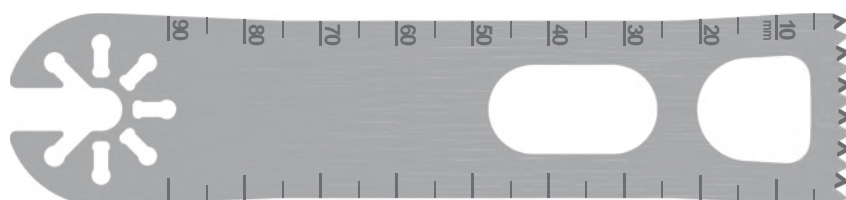

S15-506	-	85	25	2.1	1.19	1.27
----------------	---	----	----	-----	------	------

All blades shown actual size (1:1). All measurements in mm.

Linvatec®, Hall®, Hall 50®, MicroPower+®, MicroPower®, Mpower®, PowerPro®, are registered trademarks and MicroFree®, Micro 100™ are trademarks of ConMed Corporation.

cm 1 2 3 4 5 6 7 8 9 10 11 12 13 14 15 16



Conmed Linvatec® / Hall® Sterile Packed Compatible Blades

Part No.	OEM Part No.	Useable Length	Blade Width	Tooth Pitch	Blade Thickness	Cut Thickness
----------	--------------	----------------	-------------	-------------	-----------------	---------------

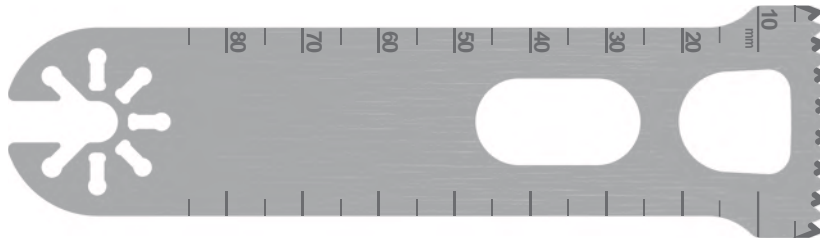

S15-508	-	85	31	2.1	1.19	1.27
----------------	---	----	----	-----	------	------

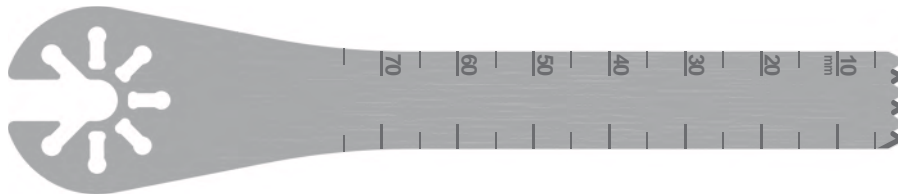

S15-511	-	95	13	2.1	1.19	1.27
----------------	---	----	----	-----	------	------

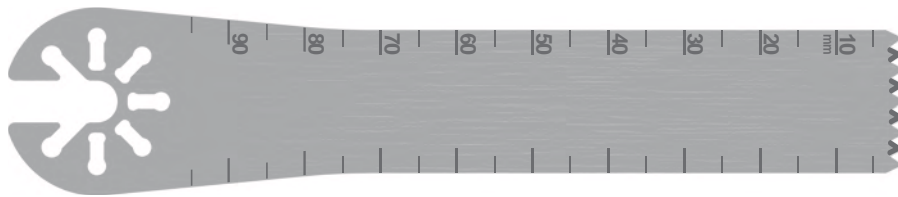

S15-513	-	95	19	2.1	1.19	1.27
----------------	---	----	----	-----	------	------

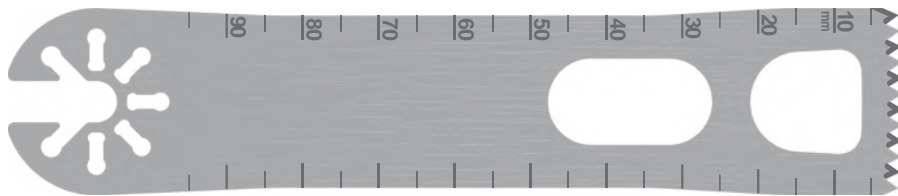

S15-516	-	95	25	2.1	1.19	1.27
----------------	---	----	----	-----	------	------

All blades shown actual size (1:1). All measurements in mm.

Linvatec®, Hall®, Hall 50®, MicroPower+®, MicroPower®, Mpower®, PowerPro®, are registered trademarks and MicroFree®, Micro 100™ are trademarks of ConMed Corporation.

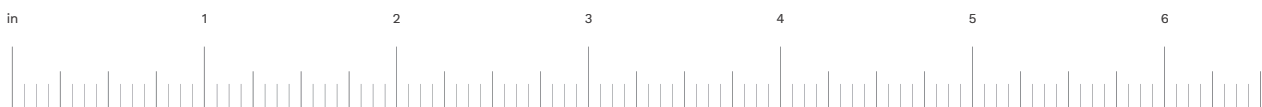

Conmed Linvatec® / Hall® Sterile Packed Compatible Blades

Part No.	OEM Part No.	Useable Length	Blade Width	Tooth Pitch	Blade Thickness	Cut Thickness
----------	--------------	----------------	-------------	-------------	-----------------	---------------

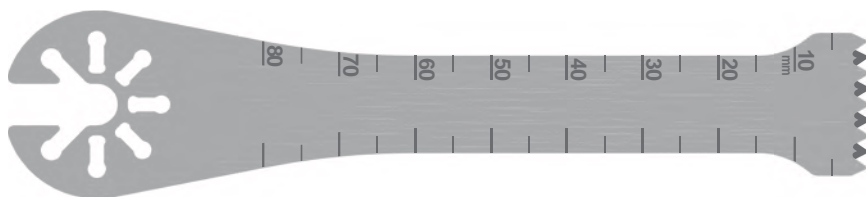

S15-523	-	90	19	2.1	1.37	1.37
----------------	---	----	----	-----	------	------

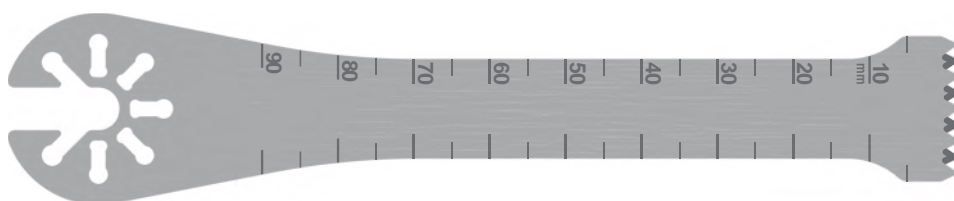

S15-524	-	100	19	2.1	1.19	1.19
----------------	---	-----	----	-----	------	------

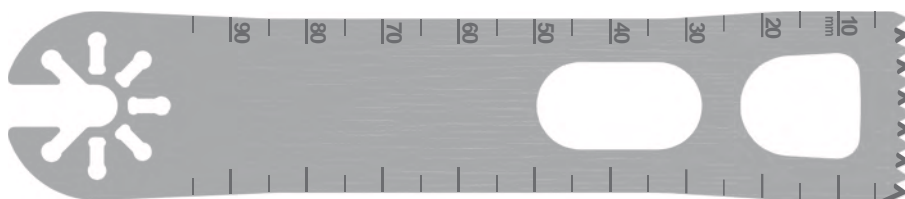

S15-527	-	95	25	2.1	1.30	1.37
----------------	---	----	----	-----	------	------

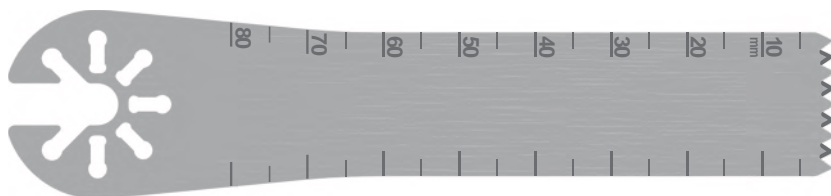

S15-553	-	85	19	2.1	0.89	0.95
----------------	---	----	----	-----	------	------

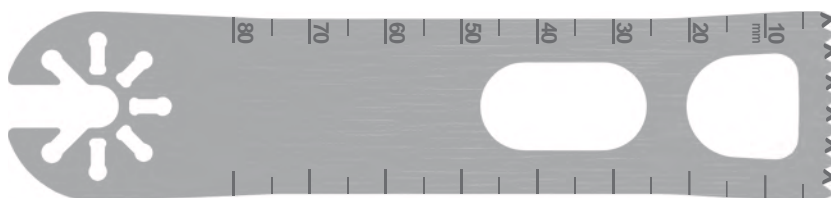

S15-556	-	85	25	2.1	0.89	0.97
----------------	---	----	----	-----	------	------

All blades shown actual size (1:1). All measurements in mm.

Linvatec®, Hall®, Hall 50®, MicroPower+®, MicroPower®, Mpower®, PowerPro®, are registered trademarks and MicroFree®, Micro 100™ are trademarks of ConMed Corporation.

cm 1 2 3 4 5 6 7 8 9 10 11 12 13 14 15 16





Conmed Linvatec® / Hall® Sterile Packed Compatible Blades

Part No.	OEM Part No.	Useable Length	Blade Width	Tooth Pitch	Blade Thickness	Cut Thickness
----------	--------------	----------------	-------------	-------------	-----------------	---------------

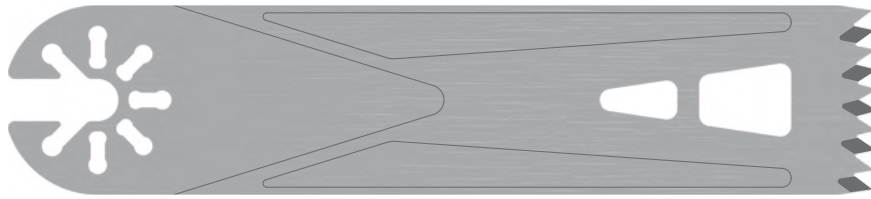

S15-561	5071-161	90	25.4	2.6	1.27	1.27
----------------	----------	----	------	-----	------	------

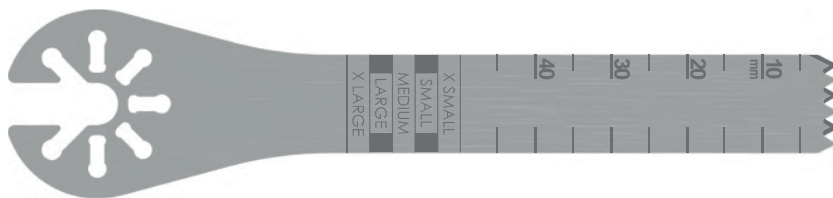

S15-562	-	85	13	2.1	0.89	0.89
----------------	---	----	----	-----	------	------

All blades shown actual size (1:1). All measurements in mm.

Linvatec®, Hall®, Hall 50®, MicroPower+®, MicroPower®, Mpower®, PowerPro®, are registered trademarks and MicroFree®, Micro 100™ are trademarks of ConMed Corporation.

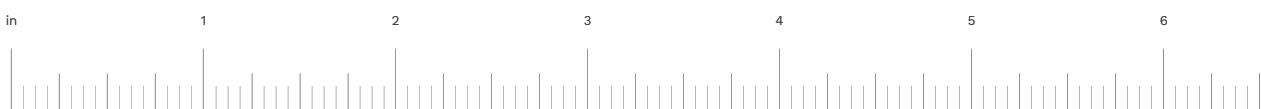

Conmed Linvatec® / Hall® Sterile Packed Compatible Blades

Part No.	OEM Part No.	Useable Length	Blade Width	Tooth Pitch	Blade Thickness	Cut Thickness
----------	--------------	----------------	-------------	-------------	-----------------	---------------

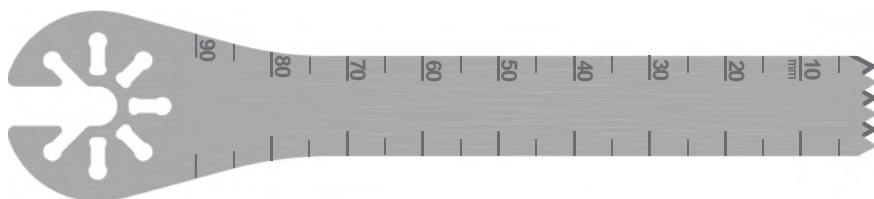

S15-6632	T130-089-90 V130-089-90 5071-340	90	13	2.1	0.89	0.89
S15-6633	T130-100-90 V130-100-90 5071-341	90	13	2.1	1.00	1.00
S15-6635	T130-119-90 V130-119-90 5071-343	90	13	2.1	1.19	1.19
S15-6636	T130-127-90 V130-127-90 5071-344	90	13	2.1	1.27	1.27

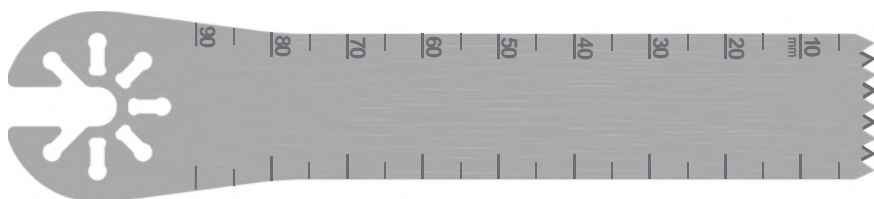

S15-6652	T190-089-90 V190-089-90 5071-300	90	19	2.1	0.89	0.89
S15-6653	T190-100-90 V190-100-90 5071-301	90	19	2.1	1.00	1.00
S15-6655	T190-119-90 V190-119-90 5071-303	90	19	2.1	1.19	1.19
S15-6656	T190-127-90 V190-127-90 5071-304	90	19	2.1	1.27	1.27
S15-6657	T190-137-90 V190-137-90 5071-305	90	19	2.1	1.37	1.37
S15-6658	T190-147-90 V190-147-90 5071-306	90	19	2.1	1.47	1.47

All blades shown actual size (1:1). All measurements in mm.

Linvatec®, Hall®, Hall 50®, MicroPower+®, MicroPower®, Mpower®, PowerPro®, are registered trademarks and MicroFree®, Micro 100™ are trademarks of ConMed Corporation.

cm 1 2 3 4 5 6 7 8 9 10 11 12 13 14 15 16





Conmed Linvatec® / Hall® Sterile Packed Compatible Blades

Part No.	OEM Part No.	Useable Length	Blade Width	Tooth Pitch	Blade Thickness	Cut Thickness
----------	--------------	----------------	-------------	-------------	-----------------	---------------

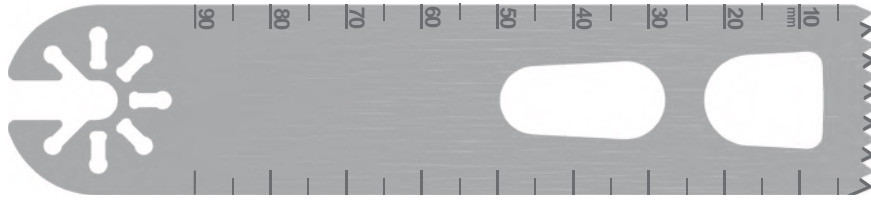

S15-6672	T250-089-90 V250-089-90 5071-320	90	25	2.1	0.89	0.89
S15-6673	T250-100-90 V250-100-90 5071-321	90	25	2.1	1.00	1.00
S15-6675	T250-119-90 V250-119-90 5071-323	90	25	2.1	1.19	1.19
S15-6676	T250-127-90 V250-127-90 5071-324	90	25	2.1	1.27	1.27
S15-6677	T250-137-90 V250-137-90 5071-325	90	25	2.1	1.37	1.37
S15-6678	T250-147-90 V250-147-90 5071-326	90	25	2.1	1.47	1.47

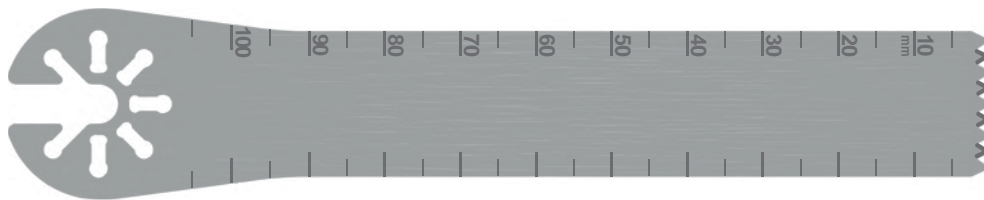

S15-6755	T190-119-05 V190-119-05	105	19	2.1	1.19	1.19
S15-6756	T190-127-05 V190-127-05 5071-529	105	19	2.1	1.27	1.27

All blades shown actual size (1:1). All measurements in mm.

Linvatec®, Hall®, Hall 50®, MicroPower+®, MicroPower®, Mpower®, PowerPro®, are registered trademarks and MicroFree®, Micro 100™ are trademarks of ConMed Corporation.

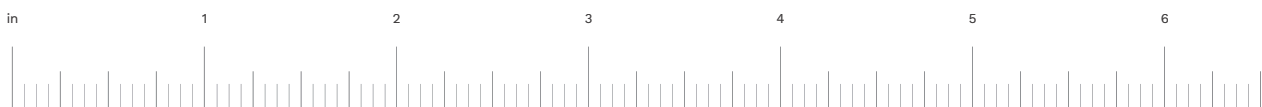

Conmed Linvatec® / Hall® Sterile Packed Compatible Blades

Part No.	OEM Part No.	Useable Length	Blade Width	Tooth Pitch	Blade Thickness	Cut Thickness
----------	--------------	----------------	-------------	-------------	-----------------	---------------



S18-104	-	16	10	1.1	0.38	0.70
----------------	---	----	----	-----	------	------



S18-118	5023-118	25.5	9.5	0.8	0.40	0.60
----------------	----------	------	-----	-----	------	------



S18-130	5023-130	25.5	19.5	1.4	0.40	0.60
----------------	----------	------	------	-----	------	------



S18-131	5023-131	41	19.5	1.4	0.40	0.60
----------------	----------	----	------	-----	------	------



S18-132	5023-132	25.5	5.5	1.4	0.40	0.60
----------------	----------	------	-----	-----	------	------

All blades shown actual size (1:1). All measurements in mm.

Linvatec®, Hall®, Hall 50®, MicroPower+®, MicroPower®, Mpower®, PowerPro®, are registered trademarks and MicroFree®, Micro 100™ are trademarks of ConMed Corporation.

cm 1 2 3 4 5 6 7 8 9 10 11 12 13 14 15 16





Conmed Linvatec® / Hall® Sterile Packed Compatible Blades

Part No.	OEM Part No.	Useable Length	Blade Width	Tooth Pitch	Blade Thickness	Cut Thickness
----------	--------------	----------------	-------------	-------------	-----------------	---------------



S18-133	5023-133	41	14	1.4	0.40	0.60
----------------	----------	----	----	-----	------	------

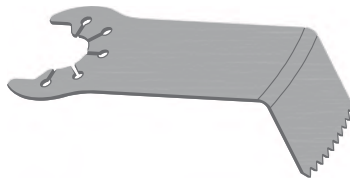

S18-136	5023-136	15.5	14	1.4	0.40	0.60
----------------	----------	------	----	-----	------	------



S18-137	5023-137	25.5	14	1.4	0.40	0.60
----------------	----------	------	----	-----	------	------



S18-138	5023-138	25.5	9.5	0.7	0.40	0.60
----------------	----------	------	-----	-----	------	------



S18-139	5023-139	25.5	4.5	0.7	0.40	0.60
----------------	----------	------	-----	-----	------	------

All blades shown actual size (1:1). All measurements in mm.

Linvatec®, Hall®, Hall 50®, MicroPower+®, MicroPower®, Mpower®, PowerPro®, are registered trademarks and MicroFree®, Micro 100™ are trademarks of ConMed Corporation.

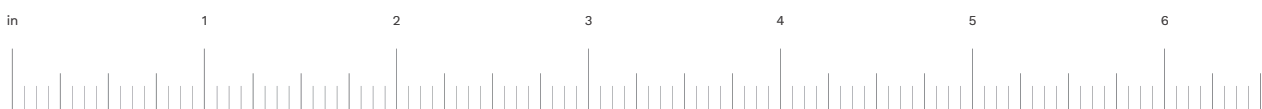

Conmed Linvatec® / Hall® Sterile Packed Compatible Blades

Part No.	OEM Part No.	Useable Length	Blade Width	Tooth Pitch	Blade Thickness	Cut Thickness
----------	--------------	----------------	-------------	-------------	-----------------	---------------



S18-140	5023-140	41	9.5	0.7	0.40	0.60
----------------	----------	----	-----	-----	------	------



S18-141	5023-141	34	6	0.7	0.40	0.60
----------------	----------	----	---	-----	------	------



S18-142	5023-142	34	4	0.7	0.40	0.60
----------------	----------	----	---	-----	------	------



S18-143	5023-143	25.5	9.5	1.4	0.40	0.60
----------------	----------	------	-----	-----	------	------



S18-144	5023-144	18.5	5.5	0.7	0.40	0.60
----------------	----------	------	-----	-----	------	------

All blades shown actual size (1:1). All measurements in mm.

Linvatec®, Hall®, Hall 50®, MicroPower+®, MicroPower®, Mpower®, PowerPro®, are registered trademarks and MicroFree®, Micro 100™ are trademarks of ConMed Corporation.

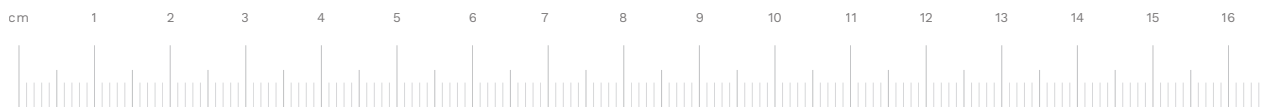



Conmed Linvatec® / Hall® Sterile Packed Compatible Blades

Part No.	OEM Part No.	Useable Length	Blade Width	Tooth Pitch	Blade Thickness	Cut Thickness
----------	--------------	----------------	-------------	-------------	-----------------	---------------



S18-160	5023-160	12	5.5	0.7	0.40	0.60
----------------	----------	----	-----	-----	------	------



S18-161	5023-161	12	10	0.7	0.40	0.60
----------------	----------	----	----	-----	------	------



S18-162	5023-162	18.5	5.5	0.7	0.40	0.60
----------------	----------	------	-----	-----	------	------



S18-163	5023-163	18.5	10	0.7	0.40	0.60
----------------	----------	------	----	-----	------	------



S18-164	5023-164	28.5	5.5	0.7	0.40	0.60
----------------	----------	------	-----	-----	------	------



S18-165	5023-165	28.5	10	0.7	0.40	0.60
----------------	----------	------	----	-----	------	------



S18-166	5023-166	28.5	18.5	0.7	0.40	0.60
----------------	----------	------	------	-----	------	------

All blades shown actual size (1:1). All measurements in mm.

Linvatec®, Hall®, Hall 50®, MicroPower+®, MicroPower®, Mpower®, PowerPro®, are registered trademarks and MicroFree®, Micro 100™ are trademarks of ConMed Corporation.

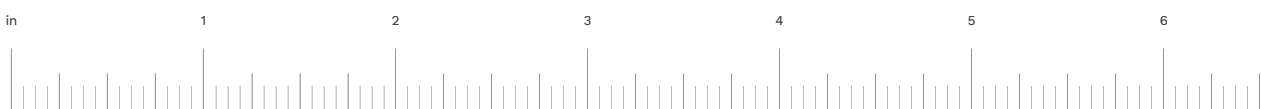

Conmed Linvatec® / Hall® Sterile Packed Compatible Blades

Part No.	OEM Part No.	Useable Length	Blade Width	Tooth Pitch	Blade Thickness	Cut Thickness
S18-173	5023-169	35	10	0.7	0.40	0.60



S18

Conmed Linvatec® / Hall® Sterile Packed Compatible Blades

All blades shown actual size (1:1). All measurements in mm.

Linvatec®, Hall®, Hall 50®, MicroPower+®, MicroPower®, Mpower®, PowerPro®, are registered trademarks and MicroFree®, Micro 100™ are trademarks of ConMed Corporation.

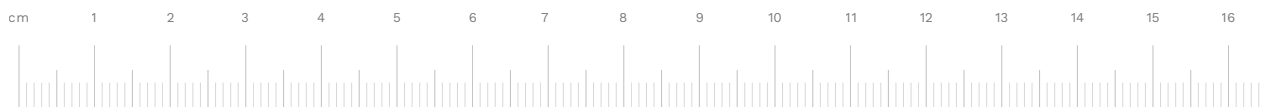

S1-17



Conmed Linvatec® / Hall® Sterile Packed Compatible Blades

Part No.	OEM Part No.	Useable Length	Blade Height	Tooth Pitch	Blade Thickness	Cut Thickness
----------	--------------	----------------	--------------	-------------	-----------------	---------------



S22-020	5053-220	25.5	7.6	1.1	0.40	0.60
----------------	----------	------	-----	-----	------	------



S22-021	5053-221	38	7.6	1.1	0.40	0.60
----------------	----------	----	-----	-----	------	------

All blades shown actual size (1:1). All measurements in mm.

Linvatec®, Hall®, Hall 50®, MicroPower+®, MicroPower®, Mpower®, PowerPro®, are registered trademarks and MicroFree®, Micro 100™ are trademarks of ConMed Corporation.

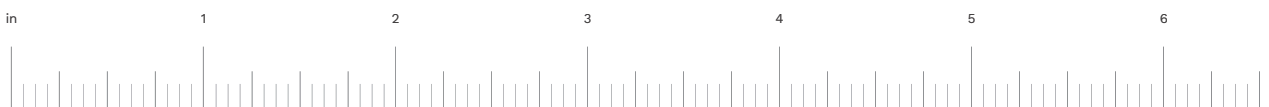

Conmed Linvatec® / Hall® Sterile Packed Compatible Blades

S22

Part No.	OEM Part No.	Useable Length	Blade Height	Blade Thickness	Cut Thickness	Sternum Guard
----------	--------------	----------------	--------------	-----------------	---------------	---------------



S22-032	5059-532	35	10	0.60	1.00	REF. OEM
----------------	----------	----	----	------	------	----------

Conmed Linvatec® / Hall® Sterile Packed Compatible Blades

All blades shown actual size (1:1). All measurements in mm.

Linvatec®, Hall®, Hall 50®, MicroPower+®, MicroPower®, Mpower®, PowerPro®, are registered trademarks and MicroFree®, Micro 100™ are trademarks of ConMed Corporation.

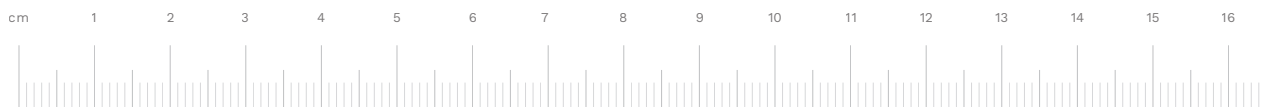

S1-19



Conmed Linvatec® / Hall® Sterile Packed Compatible Blades

Part No.	OEM Part No.	Useable Length	Blade Height	Blade Thickness	Cut Thickness	Shank Type
----------	--------------	----------------	--------------	-----------------	---------------	------------



S22-054	5053-054	25	7.4	0.40	0.60	ROUND
----------------	----------	----	-----	------	------	-------

All blades shown actual size (1:1). All measurements in mm.

Linvatec®, Hall®, Hall 50®, MicroPower+®, MicroPower®, Mpower®, PowerPro®, are registered trademarks and MicroFree®, Micro 100™ are trademarks of ConMed Corporation.

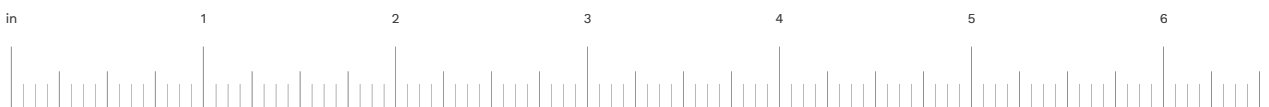

Conmed Linvatec® / Hall® Sterile Packed Compatible Blades

S22

Part No.	OEM Part No.	Useable Length	Blade Height	Tooth Pitch	Blade Thickness	Cut Thickness
----------	--------------	----------------	--------------	-------------	-----------------	---------------



S22-058	5052-258	89	12.5	1.4	0.60	1.00
----------------	----------	----	------	-----	------	------



S22-059	5052-259	54.5	9.4	1.4	0.60	1.00
----------------	----------	------	-----	-----	------	------



S22-060	5052-260	38	9.4	1.1	0.40	0.60
----------------	----------	----	-----	-----	------	------



S22-061	5052-261	89	12.5	1.4	1.50	1.60
----------------	----------	----	------	-----	------	------



S22-063	-	54.5	9.4	1.4	1.30	1.70
----------------	---	------	-----	-----	------	------



S22-273	5052-173	73.5	12.5	1.3	0.80	1.00
----------------	----------	------	------	-----	------	------



S22-275	-	80	12.5	1.3	1.00	1.20
----------------	---	----	------	-----	------	------

All blades shown actual size (1:1). All measurements in mm.

Linvatec®, Hall®, Hall 50®, MicroPower+®, MicroPower®, Mpower®, PowerPro®, are registered trademarks and MicroFree®, Micro 100™ are trademarks of ConMed Corporation.

cm 1 2 3 4 5 6 7 8 9 10 11 12 13 14 15 16





Conmed Linvatec® / Hall® Sterile Packed Compatible Blades

Part No.	OEM Part No.	Useable Length	Blade Height	Tooth Pitch	Blade Thickness	Cut Thickness
----------	--------------	----------------	--------------	-------------	-----------------	---------------

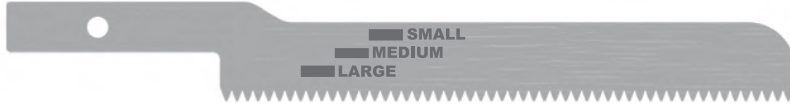

S22-364	-	76	10	1.4	1.00	1.20
----------------	---	----	----	-----	------	------

All blades shown actual size (1:1). All measurements in mm.

Linvatec®, Hall®, Hall 50®, MicroPower+®, MicroPower®, Mpower®, PowerPro®, are registered trademarks and MicroFree®, Micro 100™ are trademarks of ConMed Corporation.

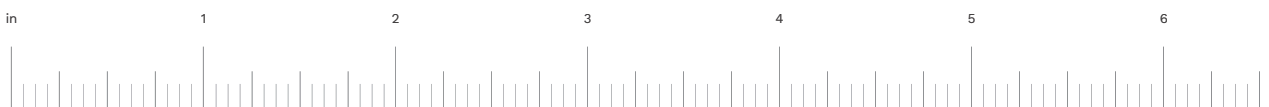

Conmed Linvatec® / Hall® Sterile Packed Compatible Blades

S22

Part No.	OEM Part No.	Useable Length	Blade Height	Blade Thickness	Cut Thickness	Type
----------	--------------	----------------	--------------	-----------------	---------------	------



S22-381	-	15	14	2.93	2.93	CEMENTLESS
----------------	---	----	----	------	------	------------

Conmed Linvatec® / Hall® Sterile Packed Compatible Blades

All blades shown actual size (1:1). All measurements in mm.

Linvatec®, Hall®, Hall 50®, MicroPower+®, MicroPower®, Mpower®, PowerPro®, are registered trademarks and MicroFree®, Micro 100™ are trademarks of ConMed Corporation.



S1-23

Aesculap® Sterile Packed Compatible Blades

**Sagittal
Saws**



S28

Acculan 4
Acculan® 3Ti

**Reciprocating
Saws**



S25

Acculan 4
Acculan® 3Ti

**Sternum
Saws**



S25

Acculan 4
Acculan® 3Ti

All blades shown actual size (1:1). All measurements in mm.

Aesculap® and Acculan® 3Ti are registered trademarks of Aesculap AG & Co. KG.

cm 1 2 3 4 5 6 7 8 9 10 11 12 13 14 15 16





Aesculap® Sterile Packed Compatible Blades

Part No.	OEM Part No.	Useable Length	Blade Height/Width	Blade Thickness	Cut Thickness	Type
----------	--------------	----------------	--------------------	-----------------	---------------	------

S02-001	PROCEDURE PACK - 3 PACK - OXFORD CEMENTLESS - AESCULAP® S25 & S28					
----------------	--	--	--	--	--	--



S25-381	-	15	14	2.93	2.93	CEMENTLESS
----------------	---	----	----	------	------	------------

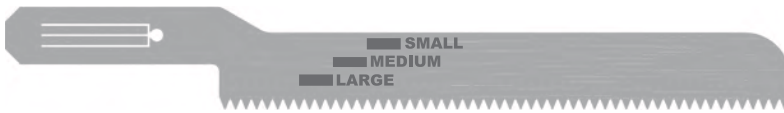

S25-364	-	76	10	1.00	1.20	-
----------------	---	----	----	------	------	---

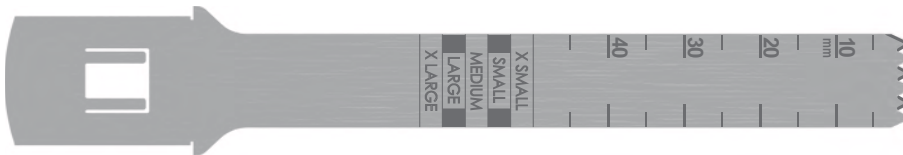

S28-6632	GE234SU	90	13	0.89	0.89	-
-----------------	---------	----	----	------	------	---

All blades shown actual size (1:1). All measurements in mm.

Aesculap® and Acculan® 3Ti are registered trademarks of Aesculap AG & Co. KG.

in 1 2 3 4 5 6



Aesculap® Sterile Packed Compatible Blades

S25

Part No.	OEM Part No.	Useable Length	Blade Width	Tooth Pitch	Blade Thickness	Cut Thickness
----------	--------------	----------------	-------------	-------------	-----------------	---------------



S25-273	GC770R	75	12	1.3	0.70	0.90
----------------	--------	----	----	-----	------	------

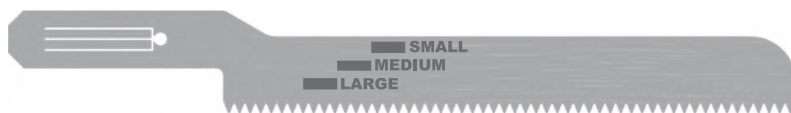

S25-364	-	76	10	1.4	1.00	1.20
----------------	---	----	----	-----	------	------

All blades shown actual size (1:1). All measurements in mm.

Aesculap® and Acculan® 3Ti are registered trademarks of Aesculap AG & Co. KG.

cm 1 2 3 4 5 6 7 8 9 10 11 12 13 14 15 16





Aesculap® Sterile Packed Compatible Blades

Part No.	OEM Part No.	Useable Length	Blade Height	Blade Thickness	Cut Thickness	Type
----------	--------------	----------------	--------------	-----------------	---------------	------



S25-381	-	15	14	2.93	2.93	CEMENTLESS
----------------	---	----	----	------	------	------------

All blades shown actual size (1:1). All measurements in mm.

Aesculap® and Acculan® 3Ti are registered trademarks of Aesculap AG & Co. KG.



Aesculap® Sterile Packed Compatible Blades

S25

Part No.	OEM Part No.	Useable Length	Blade Height	Blade Thickness	Cut Thickness	Sternum Guard
----------	--------------	----------------	--------------	-----------------	---------------	---------------



S25-624	GC624R	34	7.4	0.70	1.30	REF. OEM
----------------	--------	----	-----	------	------	----------



S25-761	GC761R	34	7.4	0.70	1.10	REF. OEM
----------------	--------	----	-----	------	------	----------

All blades shown actual size (1:1). All measurements in mm.

Aesculap® and Acculan® 3Ti are registered trademarks of Aesculap AG & Co. KG.





Aesculap® Sterile Packed Compatible Blades

Part No.	OEM Part No.	Useable Length	Blade Height	Tooth Pitch	Blade Thickness	Cut Thickness
----------	--------------	----------------	--------------	-------------	-----------------	---------------



S25-768	GC768R	75	10	1.3	0.70	0.90
----------------	--------	----	----	-----	------	------

All blades shown actual size (1:1). All measurements in mm.

Aesculap® and Acculan® 3Ti are registered trademarks of Aesculap AG & Co. KG.



Aesculap® Sterile Packed Compatible Blades

S28

Part No.	OEM Part No.	Useable Length	Blade Width	Tooth Pitch	Blade Thickness	Cut Thickness
----------	--------------	----------------	-------------	-------------	-----------------	---------------

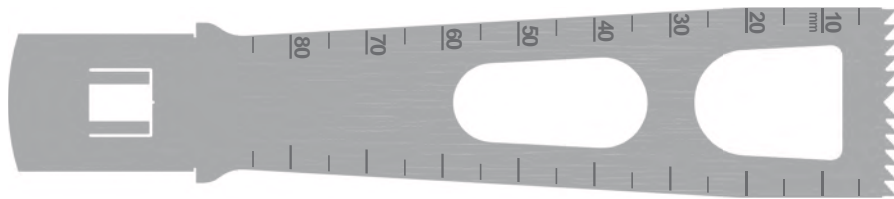

S28-206	-	90	25	2.1	1.19	1.27
----------------	---	----	----	-----	------	------

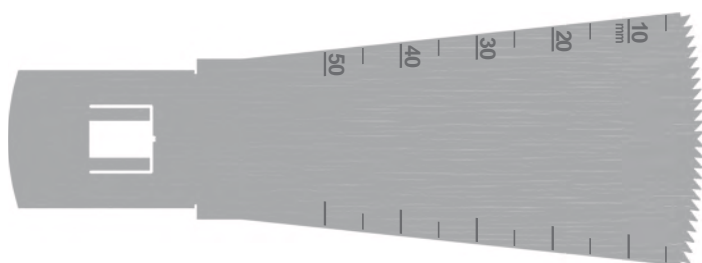

S28-256	-	60	33	1.4	0.80	0.95
----------------	---	----	----	-----	------	------

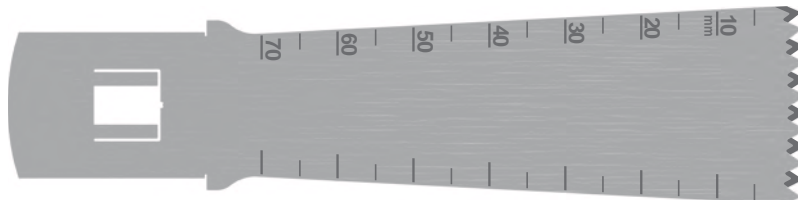

S28-502	-	70	25	2.1	0.80	1.00
----------------	---	----	----	-----	------	------



S28-511	-	95	13	2.1	1.19	1.27
----------------	---	----	----	-----	------	------



S28-513	-	95	19	2.1	1.19	1.27
----------------	---	----	----	-----	------	------

All blades shown actual size (1:1). All measurements in mm.

Aesculap® and Acculan® 3Ti are registered trademarks of Aesculap AG & Co. KG.

cm 1 2 3 4 5 6 7 8 9 10 11 12 13 14 15 16



Aesculap® Sterile Packed Compatible Blades

Part No.	OEM Part No.	Useable Length	Blade Width	Tooth Pitch	Blade Thickness	Cut Thickness
----------	--------------	----------------	-------------	-------------	-----------------	---------------

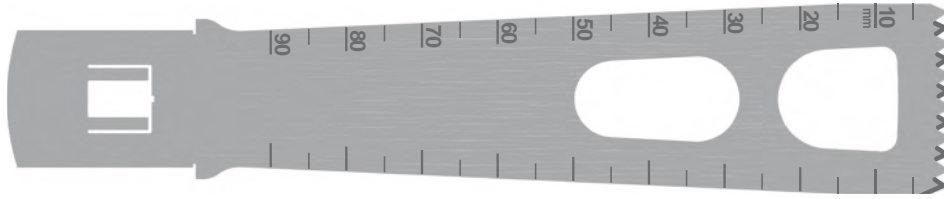

S28-526	GC296SU	95	25	2.1	1.27	1.27
----------------	---------	----	----	-----	------	------

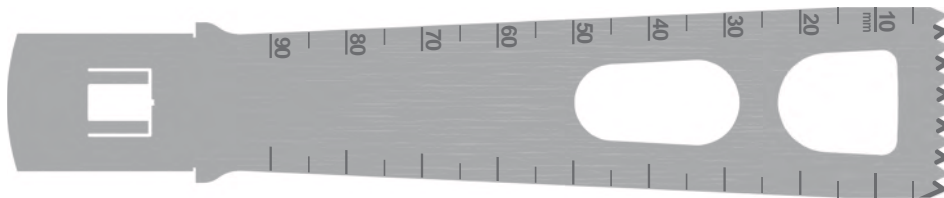

S28-527	-	95	25	2.1	1.30	1.37
----------------	---	----	----	-----	------	------

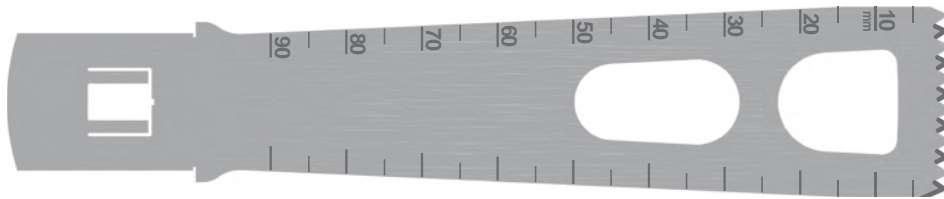

S28-528	-	95	25	2.1	1.27	1.47
----------------	---	----	----	-----	------	------

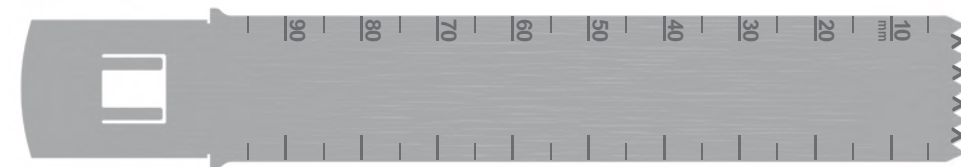

S28-533	GE239SU	95	19	2.1	1.00	1.00
----------------	---------	----	----	-----	------	------

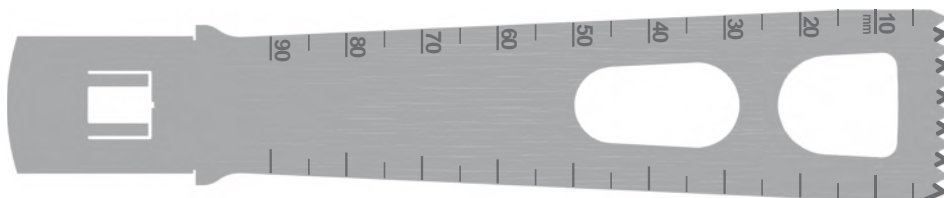

S28-536	GC244R	95	25	2.1	1.00	1.00
----------------	--------	----	----	-----	------	------

All blades shown actual size (1:1). All measurements in mm.

Aesculap® and Acculan® 3Ti are registered trademarks of Aesculap AG & Co. KG.

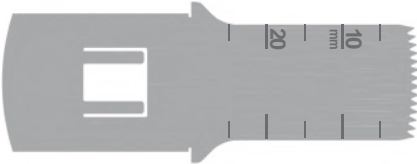
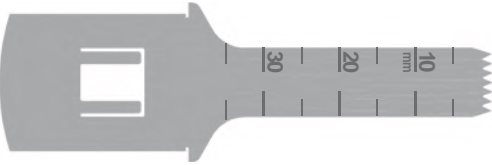
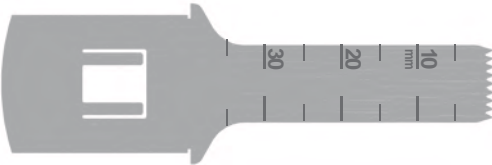
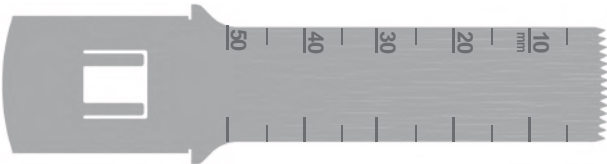
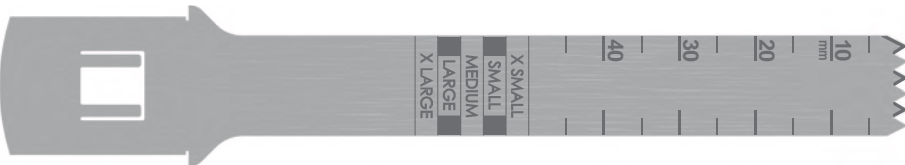

Aesculap® Sterile Packed Compatible Blades

Part No.	OEM Part No.	Useable Length	Blade Width	Tooth Pitch	Blade Thickness	Cut Thickness
						
S28-1140	GC208R	25	15	1.1	0.50	0.50
						
S28-1211	-	35	9	1.3	0.60	0.80
						
S28-1221	GC209R	35	10	1.1	0.50	0.80
						
S28-1341	GC216R	50	15	1.1	0.50	0.80
						
S28-6632	GE234SU	90	13	2.1	0.89	0.89
S28-6636	GE236SU	90	13	2.1	1.27	1.27

All blades shown actual size (1:1). All measurements in mm.

Aesculap® and Acculan® 3Ti are registered trademarks of Aesculap AG & Co. KG.

cm 1 2 3 4 5 6 7 8 9 10 11 12 13 14 15 16



Aesculap® Sterile Packed Compatible Blades

Part No.	OEM Part No.	Useable Length	Blade Width	Tooth Pitch	Blade Thickness	Cut Thickness
----------	--------------	----------------	-------------	-------------	-----------------	---------------

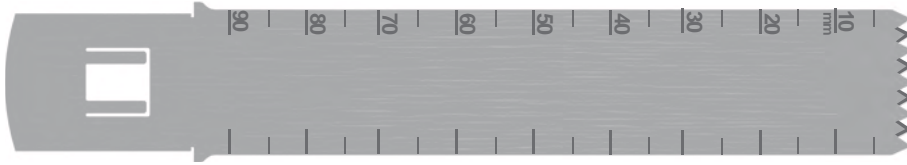

S28-6652	GE238SU	90	19	2.1	0.89	0.89
S28-6655	GE240SU	90	19	2.1	1.19	1.19
S28-6656	GE241SU	90	19	2.1	1.27	1.27

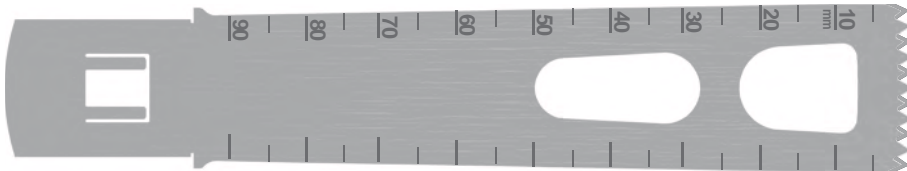

S28-6663	GE244SU	90	22	2.1	1.00	1.00
S28-6665	GE245SU	90	22	2.1	1.19	1.19
S28-6666	GE246SU	90	22	2.1	1.27	1.27
S28-6667	GE247SU	90	22	2.1	1.37	1.37

All blades shown actual size (1:1). All measurements in mm.

Aesculap® and Acculan® 3Ti are registered trademarks of Aesculap AG & Co. KG.



Synthes® Sterile Packed Compatible Blades

Sagittal Saws



S40

TRS
 Battery Power Line I/II
 ComPact™ Air Drive I/II
 Air Power Line I/II



S44

Colibri™ I/II



S42

Electric Pen Drive
 Air Pen Drive

Reciprocating Saws



S48

TRS
 Battery Power Line I
 ComPact™ Air Drive I/II
 Air Power Line I/II

All blades shown actual size (1:1). All measurements in mm.

Synthes® is a registered trademark and ComPact™ and Colibri™ are trademarks of Synthes-Stratec.

cm 1 2 3 4 5 6 7 8 9 10 11 12 13 14 15 16



Synthes® Sterile Packed Compatible Blades

Part No.	OEM Part No.	Useable Length	Blade Height/Width	Blade Thickness	Cut Thickness	Type
----------	--------------	----------------	--------------------	-----------------	---------------	------

S04-001	PROCEDURE PACK - 3 PACK - OXFORD CEMENTLESS - SYNTHES S48 & S40					
----------------	---	--	--	--	--	--



S48-381	-	15	14	2.93	2.93	CEMENTLESS
----------------	---	----	----	------	------	------------

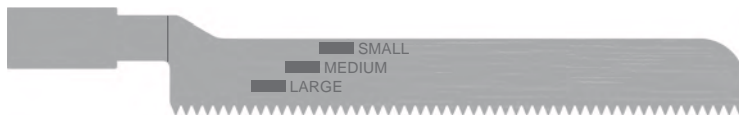

S48-364	-	76	10	1.00	1.20	-
----------------	---	----	----	------	------	---

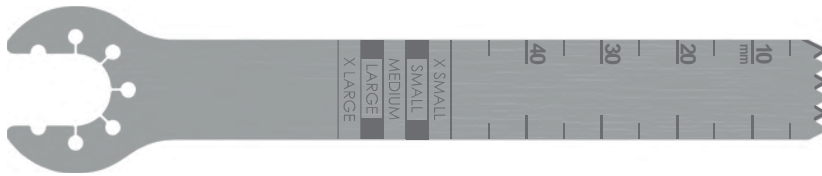

S40-561	05.002.201S	85	13	0.89	0.89	-
----------------	-------------	----	----	------	------	---

All blades shown actual size (1:1). All measurements in mm.

Synthes® is a registered trademark and ComPact™ and Colibri™ are trademarks of Synthes-Stratec.

in 1 2 3 4 5 6

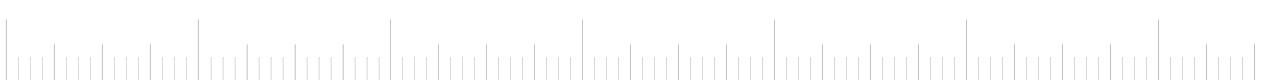

Synthes® Sterile Packed Compatible Blades

S40

Part No.	OEM Part No.	Useable Length	Blade Width	Tooth Pitch	Blade Thickness	Cut Thickness
----------	--------------	----------------	-------------	-------------	-----------------	---------------



S40-004	05.003.112S	90	19	2.1	1.00	1.00
----------------	-------------	----	----	-----	------	------

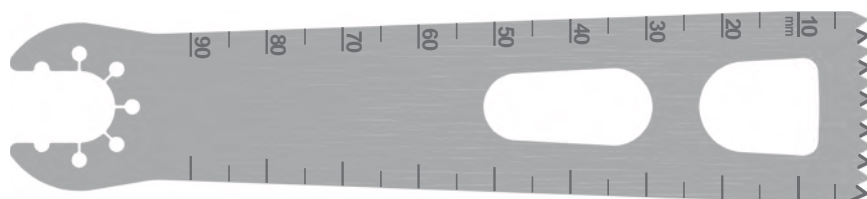

S40-005	05.003.132S	90	25	2.1	1.00	1.00
----------------	-------------	----	----	-----	------	------

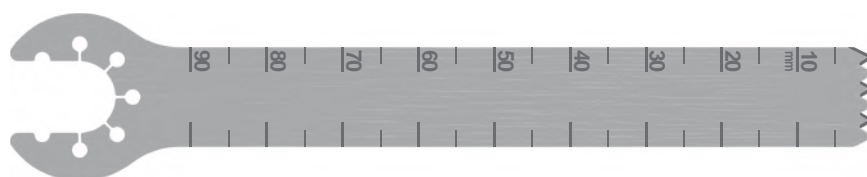

S40-006	05.002.405S	90	12.5	2.1	0.90	1.00
----------------	-------------	----	------	-----	------	------

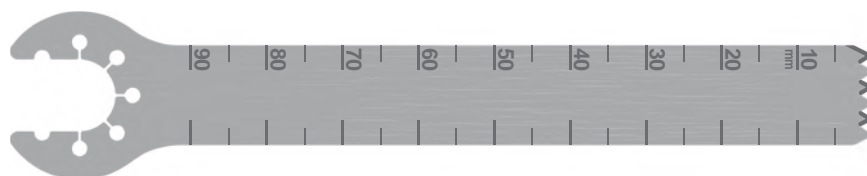

S40-007	05.003.106S	90	12.5	2.1	1.27	1.27
----------------	-------------	----	------	-----	------	------

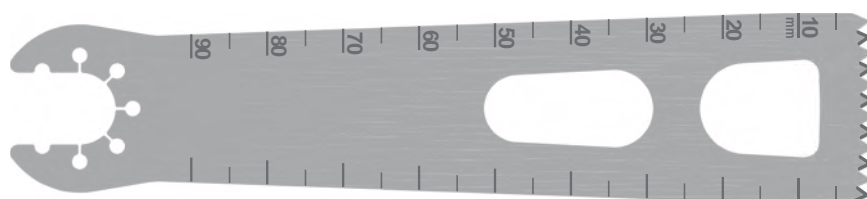

S40-008	05.003.130S	90	25	2.1	0.89	0.89
----------------	-------------	----	----	-----	------	------

All blades shown actual size (1:1). All measurements in mm.

Synthes® is a registered trademark and ComPact™ and Colibri™ are trademarks of Synthes-Stratec.

cm 1 2 3 4 5 6 7 8 9 10 11 12 13 14 15 16



Synthes® Sterile Packed Compatible Blades

Part No.	OEM Part No.	Useable Length	Blade Width	Tooth Pitch	Blade Thickness	Cut Thickness
----------	--------------	----------------	-------------	-------------	-----------------	---------------

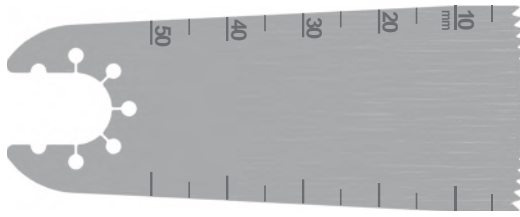

S40-010	519.100S	49	27	1.5	0.38	0.60
----------------	----------	----	----	-----	------	------

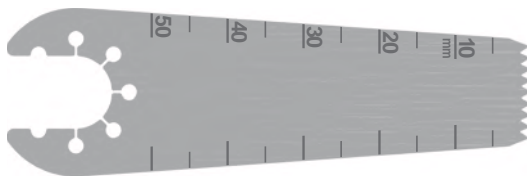

S40-015	519.150S	49	14	1.5	0.38	0.60
----------------	----------	----	----	-----	------	------

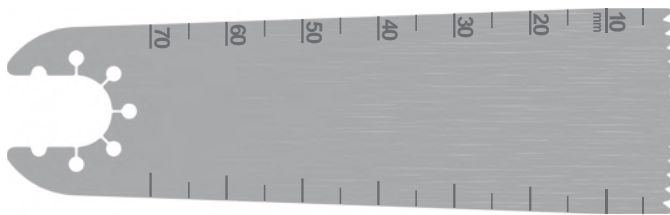

S40-017	519.170S	69	27	1.9	0.60	0.80
----------------	----------	----	----	-----	------	------

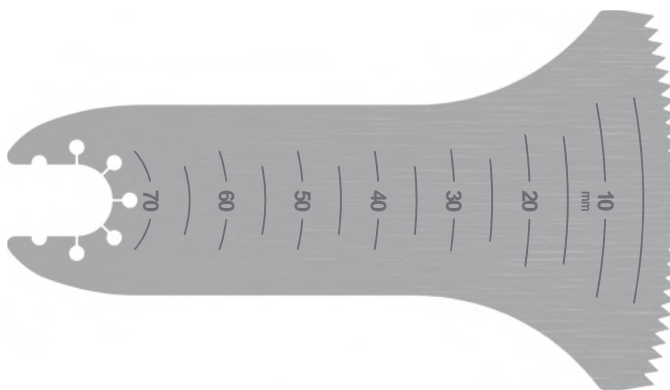

S40-019	519.190S	69	50	1.9	0.60	0.80
----------------	----------	----	----	-----	------	------

All blades shown actual size (1:1). All measurements in mm.

Synthes® is a registered trademark and ComPact™ and Colibri™ are trademarks of Synthes-Stratec.



Synthes® Sterile Packed Compatible Blades

S40

Part No.	OEM Part No.	Useable Length	Blade Width	Tooth Pitch	Blade Thickness	Cut Thickness
----------	--------------	----------------	-------------	-------------	-----------------	---------------

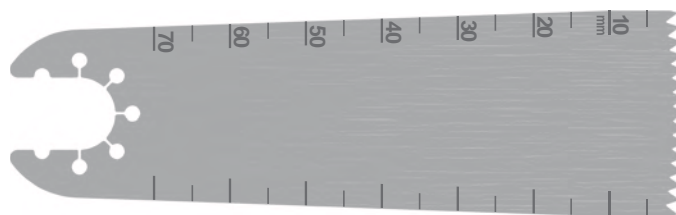

S40-020	519.200S	69	27	1.9	0.80	1.00
----------------	----------	----	----	-----	------	------

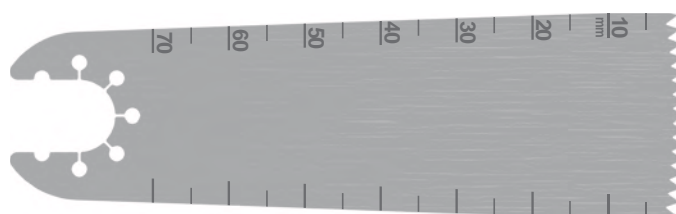

S40-021	519.210S	69	27	1.9	1.00	1.20
----------------	----------	----	----	-----	------	------

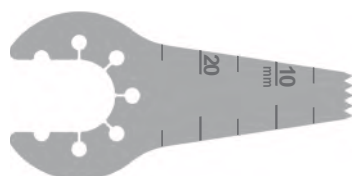

S40-023	519.230S	25	6	1.3	0.38	0.60
----------------	----------	----	---	-----	------	------

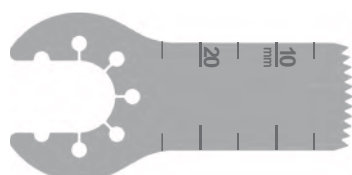

S40-025	519.250S	25	14	1.3	0.38	0.60
----------------	----------	----	----	-----	------	------

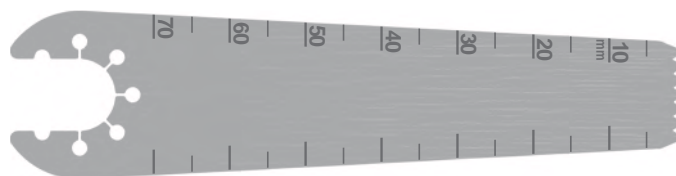

S40-057	-	70	14	1.9	0.60	0.80
----------------	---	----	----	-----	------	------

All blades shown actual size (1:1). All measurements in mm.

Synthes® is a registered trademark and ComPact™ and Colibri™ are trademarks of Synthes-Stratec.

cm 1 2 3 4 5 6 7 8 9 10 11 12 13 14 15 16



Synthes® Sterile Packed Compatible Blades

Part No.	OEM Part No.	Useable Length	Blade Width	Tooth Pitch	Blade Thickness	Cut Thickness
----------	--------------	----------------	-------------	-------------	-----------------	---------------

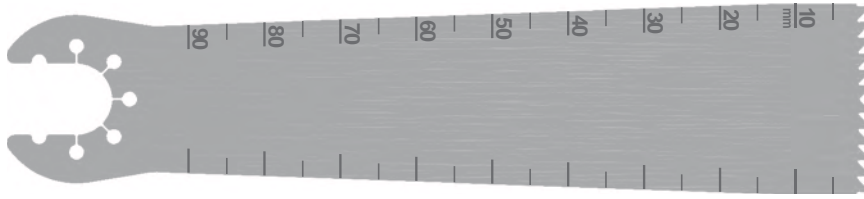

S40-200	-	90	25	2.1	0.80	0.97
----------------	---	----	----	-----	------	------

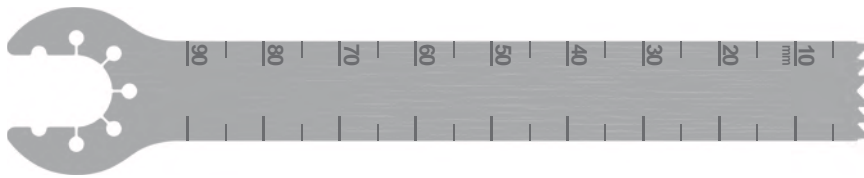

S40-201	05.003.100S	90	12.5	2.1	0.89	0.89
----------------	-------------	----	------	-----	------	------

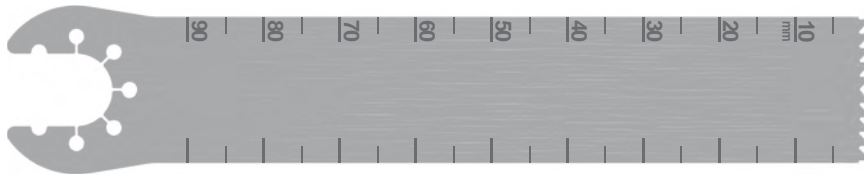

S40-205	-	90	19	1.9	1.20	1.27
----------------	---	----	----	-----	------	------

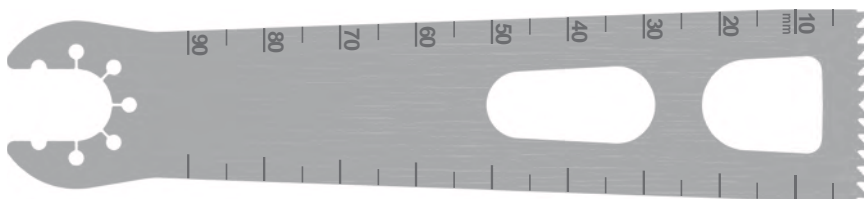

S40-206	-	90	25	2.1	1.20	1.27
----------------	---	----	----	-----	------	------

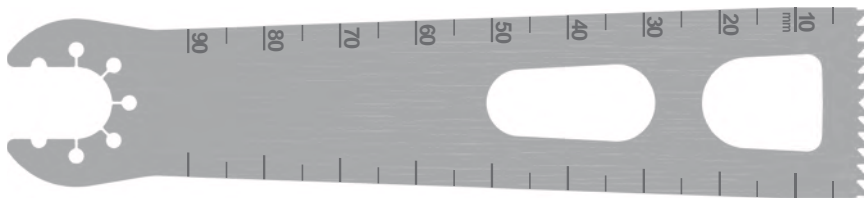

S40-209	-	90	25	2.1	1.47	1.47
----------------	---	----	----	-----	------	------

All blades shown actual size (1:1). All measurements in mm.

Synthes® is a registered trademark and ComPact™ and Colibri™ are trademarks of Synthes-Stratec.



Synthes® Sterile Packed Compatible Blades

S40

Part No.	OEM Part No.	Useable Length	Blade Width	Tooth Pitch	Blade Thickness	Cut Thickness
----------	--------------	----------------	-------------	-------------	-----------------	---------------

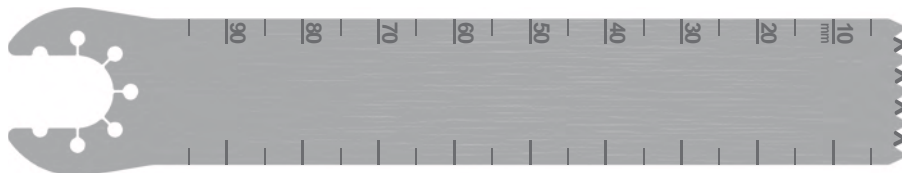

S40-513	05.002.003S	95	19	2.1	1.20	1.27
----------------	-------------	----	----	-----	------	------

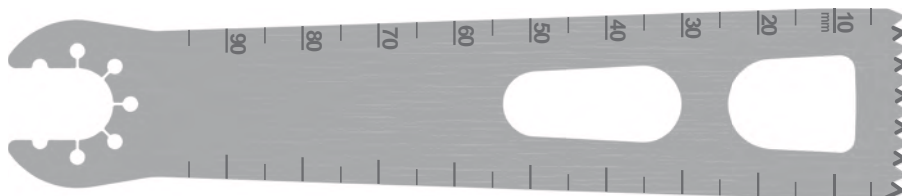

S40-516	05.002.103S	95	25	2.1	1.20	1.27
----------------	-------------	----	----	-----	------	------

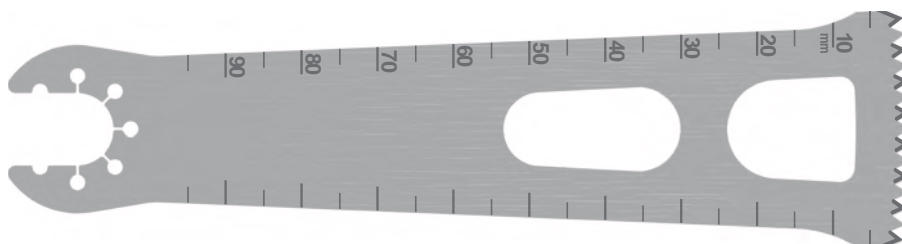

S40-518	-	95	31	2.1	1.20	1.27
----------------	---	----	----	-----	------	------

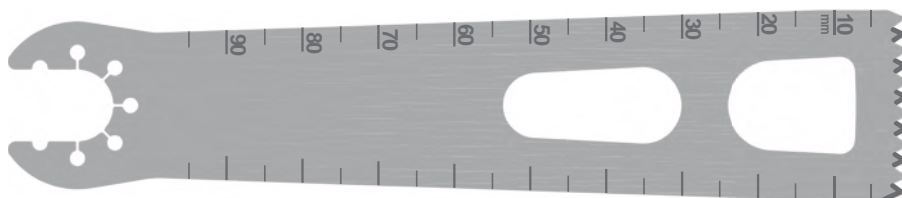

S40-528	-	95	25	2.1	1.47	1.47
----------------	---	----	----	-----	------	------

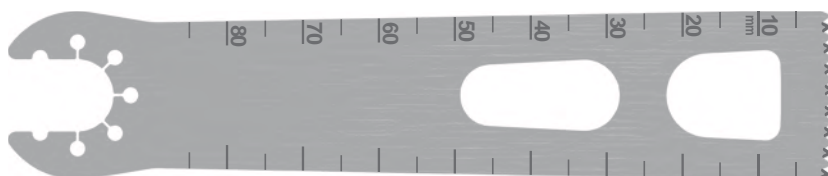

S40-530	-	85	22	1.4	0.90	1.00
----------------	---	----	----	-----	------	------

All blades shown actual size (1:1). All measurements in mm.

Synthes® is a registered trademark and ComPact™ and Colibri™ are trademarks of Synthes-Stratec.

cm 1 2 3 4 5 6 7 8 9 10 11 12 13 14 15 16



Synthes® Sterile Packed Compatible Blades

Part No.	OEM Part No.	Useable Length	Blade Width	Tooth Pitch	Blade Thickness	Cut Thickness
----------	--------------	----------------	-------------	-------------	-----------------	---------------

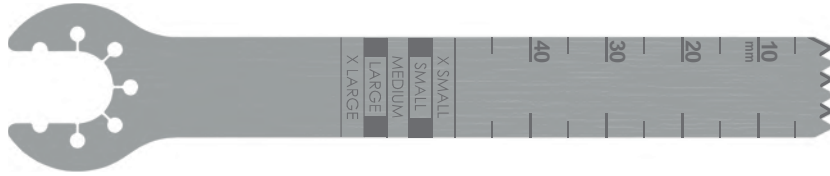

S40-561	-	85	13	2.1	0.89	0.89
----------------	---	----	----	-----	------	------

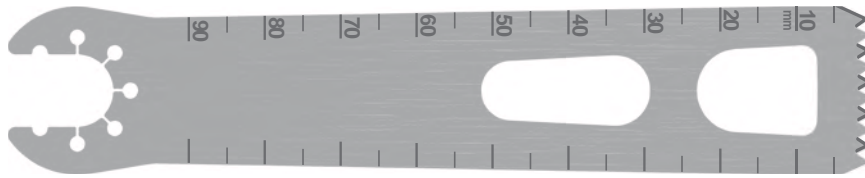

S40-571	-	90	22	2.1	1.00	1.00
----------------	---	----	----	-----	------	------

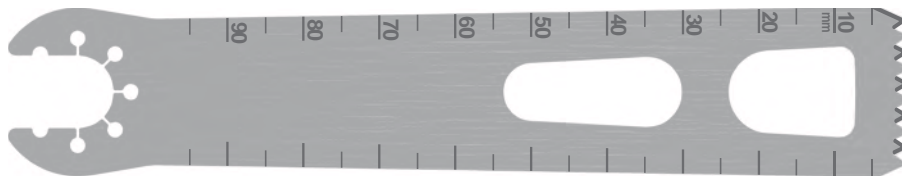

S40-575	-	95	22	2.1	1.20	1.27
----------------	---	----	----	-----	------	------

All blades shown actual size (1:1). All measurements in mm.

Synthes® is a registered trademark and ComPact™ and Colibri™ are trademarks of Synthes-Stratec.



Synthes® Sterile Packed Compatible Blades

S40

Part No.	OEM Part No.	Useable Length	Blade Width	Tooth Pitch	Blade Thickness	Cut Thickness
----------	--------------	----------------	-------------	-------------	-----------------	---------------



S40-6657	05.003.117S	90	19	2.1	1.37	1.37
-----------------	-------------	----	----	-----	------	------

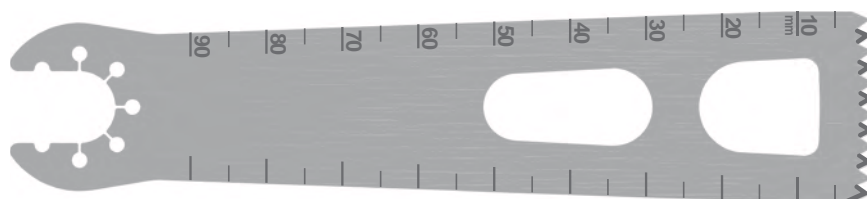

S40-6675	05.003.134S	90	25	2.1	1.19	1.19
S40-6677	05.003.137S	90	25	2.1	1.37	1.37

All blades shown actual size (1:1). All measurements in mm.

Synthes® is a registered trademark and ComPact™ and Colibri™ are trademarks of Synthes-Stratec.

cm 1 2 3 4 5 6 7 8 9 10 11 12 13 14 15 16



Synthes® Sterile Packed Compatible Blades

Part No.	OEM Part No.	Useable Length	Blade Width	Tooth Pitch	Blade Thickness	Cut Thickness
----------	--------------	----------------	-------------	-------------	-----------------	---------------



S42-300	03.000.300S	18	4	0.7	0.30	0.38
----------------	-------------	----	---	-----	------	------

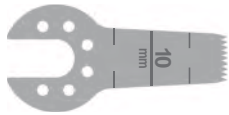

S42-301	03.000.301S	15	6	0.7	0.30	0.38
----------------	-------------	----	---	-----	------	------



S42-302	03.000.302S	31	6	0.7	0.30	0.38
----------------	-------------	----	---	-----	------	------

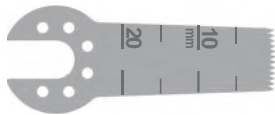

S42-303	03.000.303S	22	8	0.7	0.30	0.38
----------------	-------------	----	---	-----	------	------



S42-304	03.000.304S	15	10	0.7	0.30	0.38
----------------	-------------	----	----	-----	------	------



S42-305	03.000.305S	31	10	0.7	0.30	0.38
----------------	-------------	----	----	-----	------	------





All blades shown actual size (1:1). All measurements in mm.

Synthes® is a registered trademark and ComPact™ and Colibri™ are trademarks of Synthes-Stratec.



Synthes® Sterile Packed Compatible Blades

S42

Part No.	OEM Part No.	Useable Length	Blade Width	Tooth Pitch	Blade Thickness	Cut Thickness
						
S42-306	03.000.306S	22	12	0.7	0.30	0.38
						
S42-307	03.000.307S	15	16	0.7	0.30	0.38
						
S42-308	03.000.308S	27	6	1.4	0.40	0.60
						
S42-309	03.000.309S	27	10	1.4	0.40	0.60
						
S42-310	03.000.310S	27	14	1.4	0.40	0.60
						
S42-314	03.000.314S	18	2.5	0.7	0.30	0.38

All blades shown actual size (1:1). All measurements in mm.

Synthes® is a registered trademark and ComPact™ and Colibri™ are trademarks of Synthes-Stratec.

cm 1 2 3 4 5 6 7 8 9 10 11 12 13 14 15 16



Synthes® Sterile Packed Compatible Blades

Part No.	OEM Part No.	Useable Length	Blade Width	Tooth Pitch	Blade Thickness	Cut Thickness
----------	--------------	----------------	-------------	-------------	-----------------	---------------



S44-041	532.041S	15	6	-	0.30	0.40
----------------	----------	----	---	---	------	------

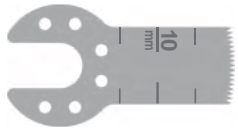

S44-042	532.042S	15	10	-	0.30	0.40
----------------	----------	----	----	---	------	------

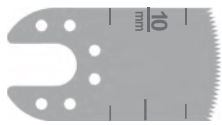

S44-043	532.043S	15	16	-	0.30	0.40
----------------	----------	----	----	---	------	------



S44-044	532.044S	18	4	-	0.30	0.40
----------------	----------	----	---	---	------	------

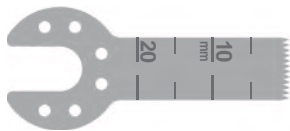

S44-045	532.045S	22	8	-	0.30	0.40
----------------	----------	----	---	---	------	------

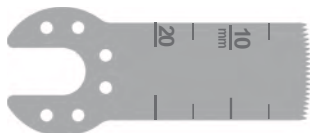

S44-046	532.046S	22	12	-	0.30	0.40
----------------	----------	----	----	---	------	------



All blades shown actual size (1:1). All measurements in mm.

Synthes® is a registered trademark and ComPact™ and Colibri™ are trademarks of Synthes-Stratec.

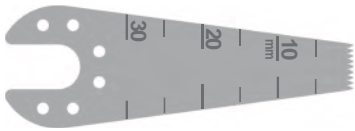
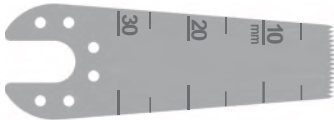
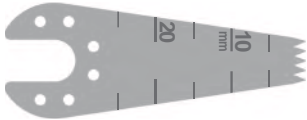

Synthes® Sterile Packed Compatible Blades

S44

Part No.	OEM Part No.	Useable Length	Blade Width	Tooth Pitch	Blade Thickness	Cut Thickness	
	S44-047	532.047S	31	6	-	0.30	0.40
	S44-048	532.048S	31	10	-	0.30	0.40
	S44-061	532.061S	27	6	-	0.40	0.60
	S44-062	532.062S	27	10	-	0.40	0.60
	S44-063	532.063S	27	14	-	0.40	0.60
	S44-064	532.064S	50	10	-	0.40	0.60

All blades shown actual size (1:1). All measurements in mm.

Synthes® is a registered trademark and ComPact™ and Colibri™ are trademarks of Synthes-Stratec.

cm 1 2 3 4 5 6 7 8 9 10 11 12 13 14 15 16



Synthes® Sterile Packed Compatible Blades

Part No.	OEM Part No.	Useable Length	Blade Width	Tooth Pitch	Blade Thickness	Cut Thickness
----------	--------------	----------------	-------------	-------------	-----------------	---------------



S44-065	532.065S	50	14	-	0.40	0.60
----------------	----------	----	----	---	------	------

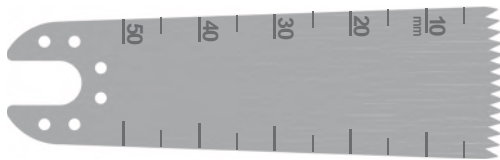

S44-066	532.066S	50	20	-	0.40	0.60
----------------	----------	----	----	---	------	------

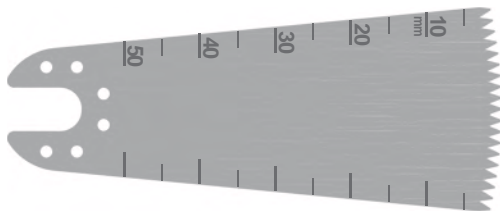

S44-067	532.067S	50	27	-	0.40	0.60
----------------	----------	----	----	---	------	------

All blades shown actual size (1:1). All measurements in mm.

Synthes® is a registered trademark and ComPact™ and Colibri™ are trademarks of Synthes-Stratec.



Synthes® Sterile Packed Compatible Blades

S48

Part No.	OEM Part No.	Useable Length	Blade Height	Tooth Pitch	Blade Thickness	Cut Thickness
----------	--------------	----------------	--------------	-------------	-----------------	---------------

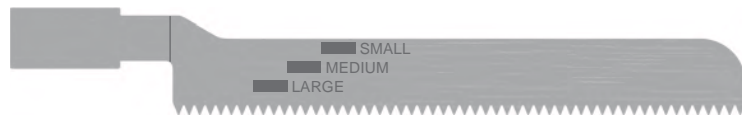

S48-364	-	76	10	1.4	1.00	1.20
----------------	---	----	----	-----	------	------

All blades shown actual size (1:1). All measurements in mm.

Synthes® is a registered trademark and ComPact™ and Colibri™ are trademarks of Synthes-Stratec.





Synthes® Sterile Packed Compatible Blades

Part No.	OEM Part No.	Useable Length	Blade Height	Blade Thickness	Cut Thickness	Type
----------	--------------	----------------	--------------	-----------------	---------------	------



S48-381	-	15	14	2.93	2.93	CEMENTLESS
----------------	---	----	----	------	------	------------

All blades shown actual size (1:1). All measurements in mm.

Synthes® is a registered trademark and ComPact™ and Colibri™ are trademarks of Synthes-Stratec.



Synthes® Sterile Packed Compatible Blades

S48

Part No.	OEM Part No.	Useable Length	Blade Height	Tooth Pitch	Blade Thickness	Cut Thickness
----------	--------------	----------------	--------------	-------------	-----------------	---------------



S48-905	511.905S	80	12	1.3	0.80	1.05
----------------	----------	----	----	-----	------	------



S48-912	511.912S	68	12	1.3	0.80	1.10
----------------	----------	----	----	-----	------	------



S48-920	-	56	10	1.2	0.60	0.80
----------------	---	----	----	-----	------	------

All blades shown actual size (1:1). All measurements in mm.

Synthes® is a registered trademark and ComPact™ and Colibri™ are trademarks of Synthes-Stratec.

cm 1 2 3 4 5 6 7 8 9 10 11 12 13 14 15 16



Stryker® Sterile Packed Compatible Blades

Sagittal
Saws



S56

System 6/7/8™



S59

Cordless Driver 4/8®

Reciprocating
Saws



S57

System 6/7/8™

Sternum
Saws



S57

System 6/7/8™

All blades shown actual size (1:1). All measurements in mm.

Stryker®, Orthopower®, Cordless Driver® is a registered trademarks and System 5™, System 6™, System 7™ and System 8™ are trademarks of Stryker Corporation.



Stryker® Sterile Packed Compatible Blades

Part No.	OEM Part No.	Useable Length	Blade Height/Width	Blade Thickness	Cut Thickness	Type
----------	--------------	----------------	--------------------	-----------------	---------------	------

S05-001	PROCEDURE PACK - 3 PACK - OXFORD CEMENTLESS - STRYKER S57 & S56					
----------------	---	--	--	--	--	--



S57-381	-	15	14	2.93	2.93	CEMENTLESS
----------------	---	----	----	------	------	------------

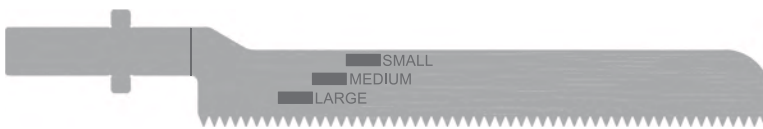

S57-364	-	76	10	1.00	1.20	-
----------------	---	----	----	------	------	---

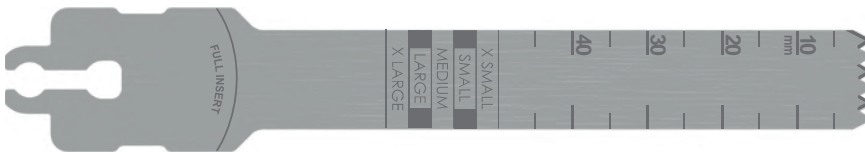

S56-561	-	85	13	0.89	0.89	-
----------------	---	----	----	------	------	---

All blades shown actual size (1:1). All measurements in mm.

Stryker®, Orthopower®, Cordless Driver® is a registered trademarks and System 5™, System 6™, System 7™ and System 8™ are trademarks of Stryker Corporation.



Stryker® Sterile Packed Compatible Blades

S56

Part No.	OEM Part No.	Useable Length	Blade Width	Tooth Pitch	Blade Thickness	Cut Thickness
----------	--------------	----------------	-------------	-------------	-----------------	---------------

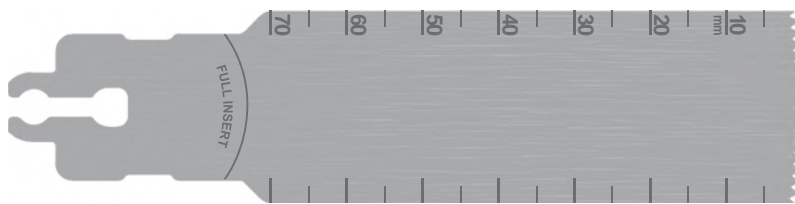

S56-100	2108-100	73	25	1.5	0.64	0.80
----------------	----------	----	----	-----	------	------



S56-102	2108-102	90	25	2.1	0.89	1.00
----------------	----------	----	----	-----	------	------



S56-115	2108-115	73	18.5	2.1	0.76	0.90
----------------	----------	----	------	-----	------	------

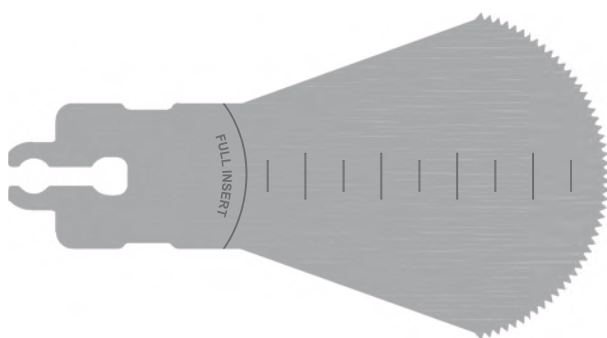

S56-125	2108-125	48	43	1.2	0.64	0.80
----------------	----------	----	----	-----	------	------

All blades shown actual size (1:1). All measurements in mm.

Stryker®, Orthopower®, Cordless Driver® is a registered trademarks and System 5™, System 6™, System 7™ and System 8™ are trademarks of Stryker Corporation.

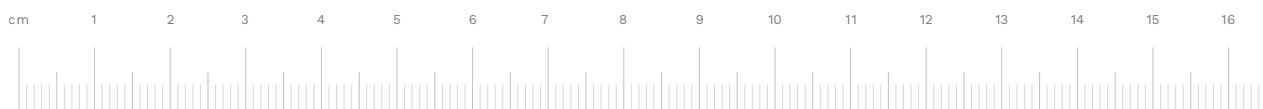

Stryker® Sterile Packed Compatible Blades

Part No.	OEM Part No.	Useable Length	Blade Width	Tooth Pitch	Blade Thickness	Cut Thickness
----------	--------------	----------------	-------------	-------------	-----------------	---------------

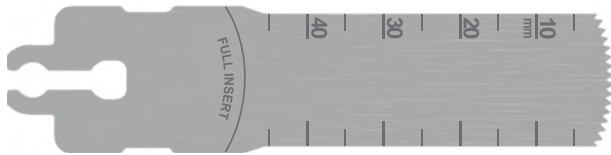

S56-131	2108-131	48	17.5	1.2	0.64	0.80
----------------	----------	----	------	-----	------	------

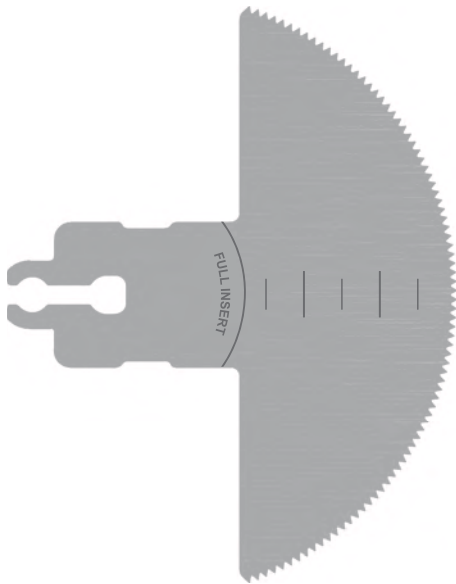

S56-137	2108-137	28	76	1.2	0.64	0.80
----------------	----------	----	----	-----	------	------

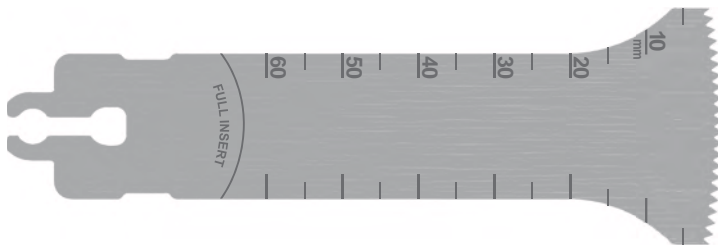

S56-140	-	63	31	1.5	0.64	0.90
----------------	---	----	----	-----	------	------

All blades shown actual size (1:1). All measurements in mm.

Stryker®, Orthopower®, Cordless Driver® is a registered trademarks and System 5™, System 6™, System 7™ and System 8™ are trademarks of Stryker Corporation.

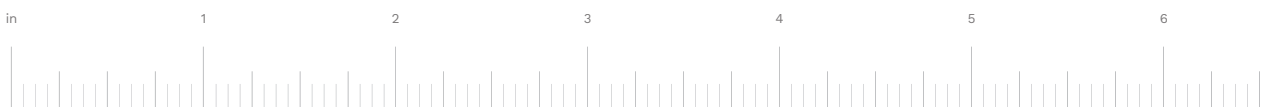

Stryker® Sterile Packed Compatible Blades

S56

Part No.	OEM Part No.	Useable Length	Blade Width	Tooth Pitch	Blade Thickness	Cut Thickness
----------	--------------	----------------	-------------	-------------	-----------------	---------------

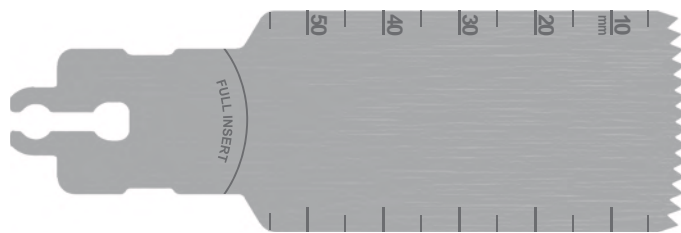

S56-141	2108-140	58	29	2.1	0.64	0.90
----------------	----------	----	----	-----	------	------



S56-145	2108-145	24	9	1.2	0.64	0.80
----------------	----------	----	---	-----	------	------

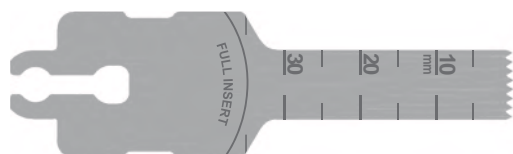

S56-148	2108-148	35	9	1.2	0.64	0.80
----------------	----------	----	---	-----	------	------

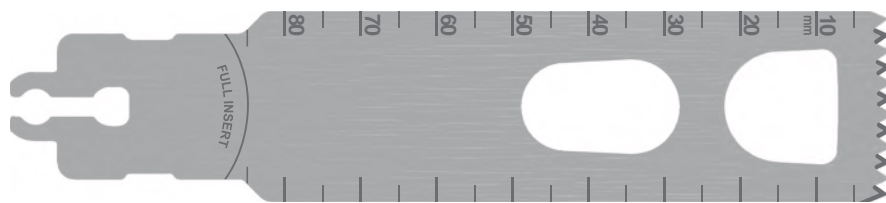

S56-151	2108-151	85	25	2.1	1.19	1.19
----------------	----------	----	----	-----	------	------

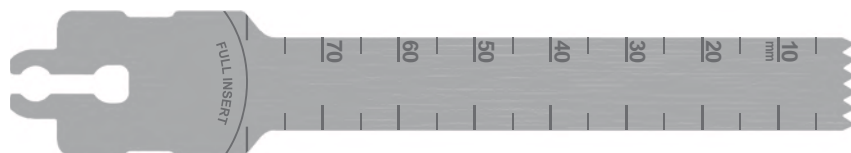

S56-156	2108-156	80	12.5	2.1	1.27	1.47
----------------	----------	----	------	-----	------	------

All blades shown actual size (1:1). All measurements in mm.

Stryker®, Orthopower®, Cordless Driver® is a registered trademarks and System 5™, System 6™, System 7™ and System 8™ are trademarks of Stryker Corporation.



Stryker® Sterile Packed Compatible Blades

Part No.	OEM Part No.	Useable Length	Blade Width	Tooth Pitch	Blade Thickness	Cut Thickness
----------	--------------	----------------	-------------	-------------	-----------------	---------------

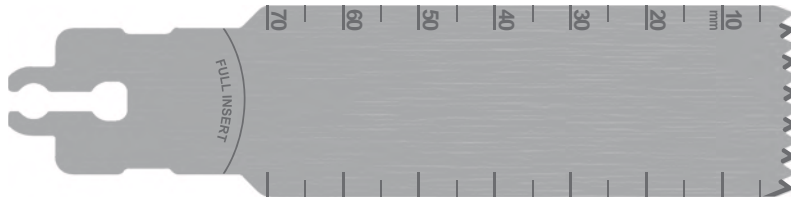

S56-177	-	73	25	2.1	1.30	1.30
----------------	---	----	----	-----	------	------



S56-182	2108-182	84	18.5	2.1	1.24	1.24
----------------	----------	----	------	-----	------	------

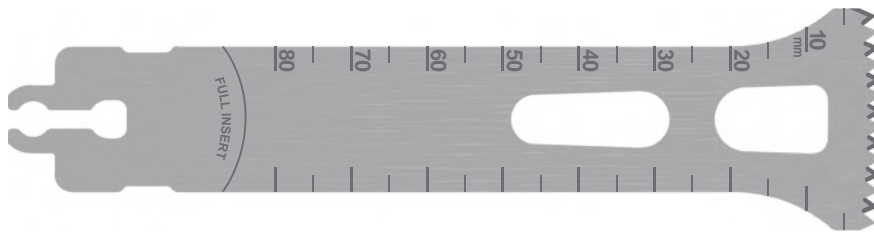

S56-183	2108-183	84	29	2.1	1.27	1.27
----------------	----------	----	----	-----	------	------

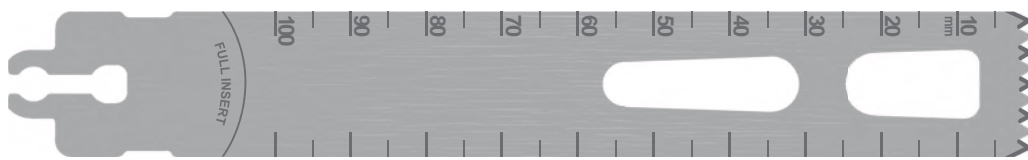

S56-185	2108-185	104	18.5	2.1	1.27	1.27
----------------	----------	-----	------	-----	------	------



S56-187	-	104	19	2.1	1.30	1.37
----------------	---	-----	----	-----	------	------

All blades shown actual size (1:1). All measurements in mm.

Stryker®, Orthopower®, Cordless Driver® is a registered trademarks and System 5™, System 6™, System 7™ and System 8™ are trademarks of Stryker Corporation.



Stryker® Sterile Packed Compatible Blades

S56

Part No.	OEM Part No.	Useable Length	Blade Width	Tooth Pitch	Blade Thickness	Cut Thickness
----------	--------------	----------------	-------------	-------------	-----------------	---------------

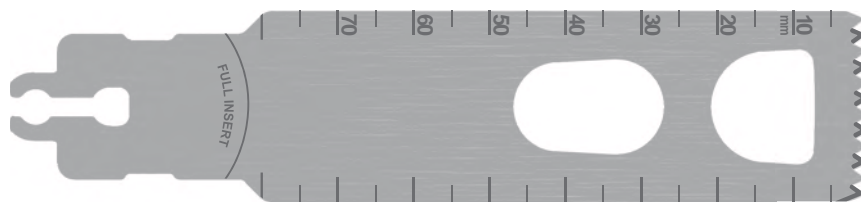

S56-189	2108-189	82	25	2.1	1.27	1.27
----------------	----------	----	----	-----	------	------

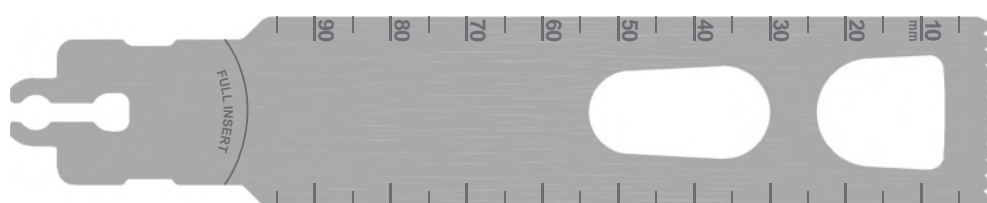

S56-218	-	99	25	2.1	1.20	1.20
----------------	---	----	----	-----	------	------



S56-328	2108-328	99	25	2.1	1.24	1.24
----------------	----------	----	----	-----	------	------



S56-401	4118-089-090	90	18	3.4	0.80	0.89
----------------	--------------	----	----	-----	------	------

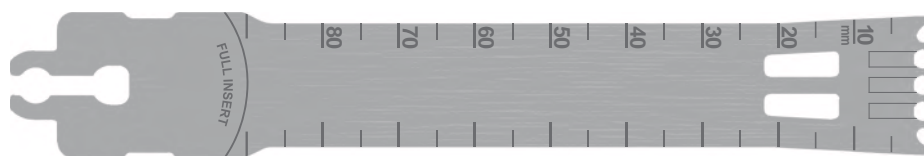

S56-402	4118-127-090	90	18	3.4	1.20	1.27
----------------	--------------	----	----	-----	------	------

All blades shown actual size (1:1). All measurements in mm.

Stryker®, Orthopower®, Cordless Driver® is a registered trademarks and System 5™, System 6™, System 7™ and System 8™ are trademarks of Stryker Corporation.

cm 1 2 3 4 5 6 7 8 9 10 11 12 13 14 15 16





Stryker® Sterile Packed Compatible Blades

Part No.	OEM Part No.	Useable Length	Blade Width	Tooth Pitch	Blade Thickness	Cut Thickness
----------	--------------	----------------	-------------	-------------	-----------------	---------------

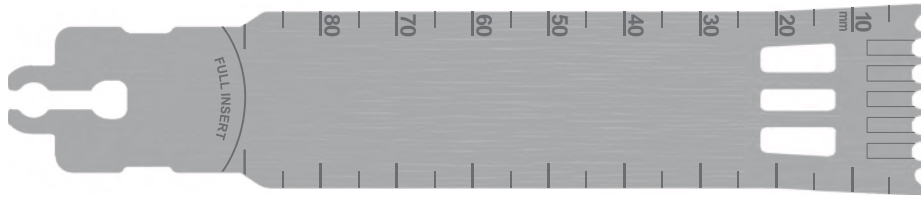

S56-403	4125-127-090	90	25	3.4	1.20	1.27
----------------	--------------	----	----	-----	------	------

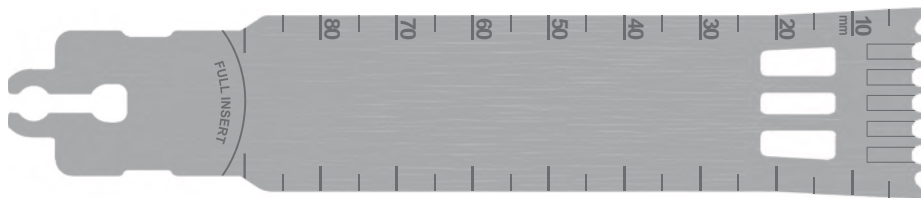

S56-404	4125-135-090	90	25	3.4	1.26	1.35
----------------	--------------	----	----	-----	------	------

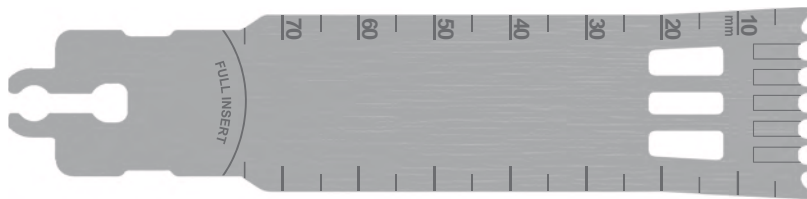

S56-405	4125-089-075	75	25	3.4	0.80	0.89
----------------	--------------	----	----	-----	------	------

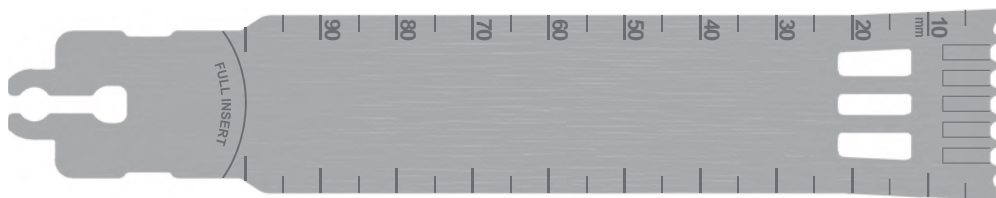

S56-406	4125-127-100	100	25	3.4	1.20	1.27
----------------	--------------	-----	----	-----	------	------

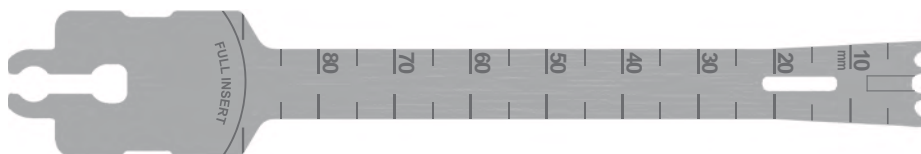

S56-407	4111-089-090	90	11	3.4	0.80	0.89
----------------	--------------	----	----	-----	------	------

All blades shown actual size (1:1). All measurements in mm.

Stryker®, Orthopower®, Cordless Driver® is a registered trademarks and System 5™, System 6™, System 7™ and System 8™ are trademarks of Stryker Corporation.



Stryker® Sterile Packed Compatible Blades

S56

Part No.	OEM Part No.	Useable Length	Blade Width	Tooth Pitch	Blade Thickness	Cut Thickness
----------	--------------	----------------	-------------	-------------	-----------------	---------------



S56-408	4111-127-090	90	11	3.4	1.20	1.27
----------------	--------------	----	----	-----	------	------

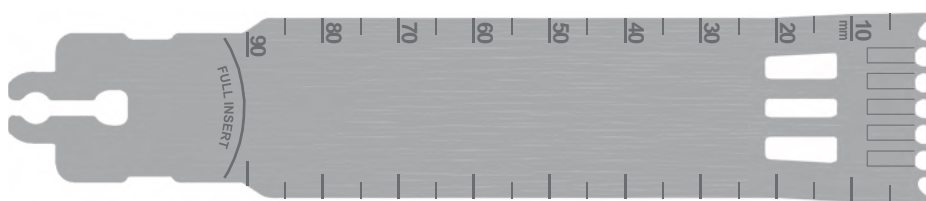

S56-409	4125-089-090	90	25	3.4	0.80	0.89
----------------	--------------	----	----	-----	------	------

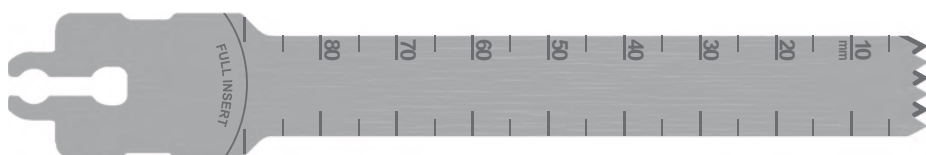

S56-502	6113-127-090	90	13	2.1	1.27	1.27
----------------	--------------	----	----	-----	------	------

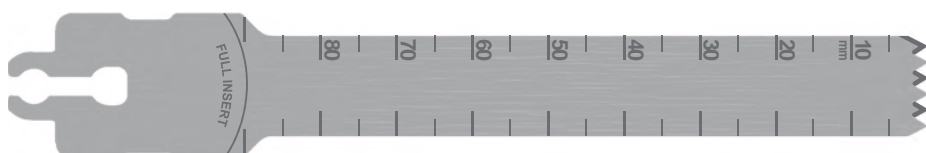

S56-505	-	90	13	2.1	1.30	1.37
----------------	---	----	----	-----	------	------

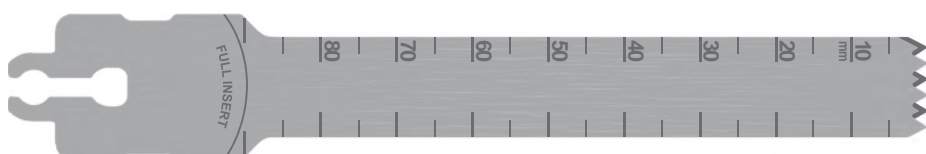

S56-507	-	90	13	2.1	1.10	1.19
----------------	---	----	----	-----	------	------

All blades shown actual size (1:1). All measurements in mm.

Stryker®, Orthopower®, Cordless Driver® is a registered trademarks and System 5™, System 6™, System 7™ and System 8™ are trademarks of Stryker Corporation.



Stryker® Sterile Packed Compatible Blades

Part No.	OEM Part No.	Useable Length	Blade Width	Tooth Pitch	Blade Thickness	Cut Thickness
----------	--------------	----------------	-------------	-------------	-----------------	---------------

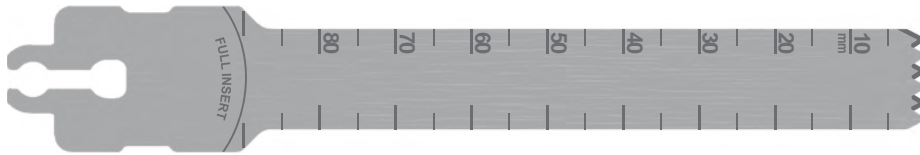

S56-510	-	90	13	2.1	0.90	0.90
----------------	---	----	----	-----	------	------

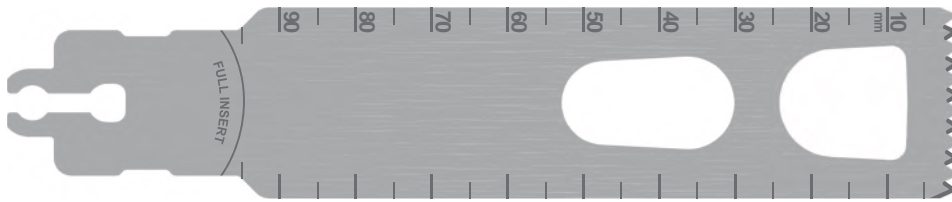

S56-515	6125-119-090	95	25	2.1	1.19	1.19
----------------	--------------	----	----	-----	------	------

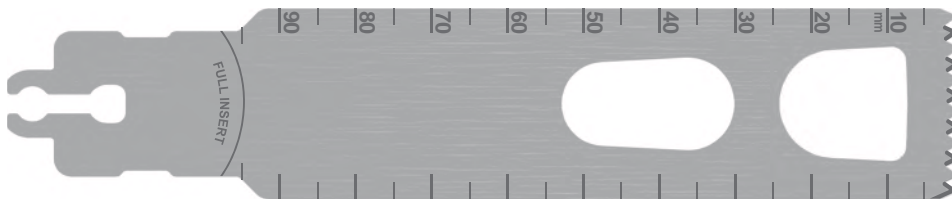

S56-518	6125-127-090	95	25	2.1	1.27	1.27
----------------	--------------	----	----	-----	------	------

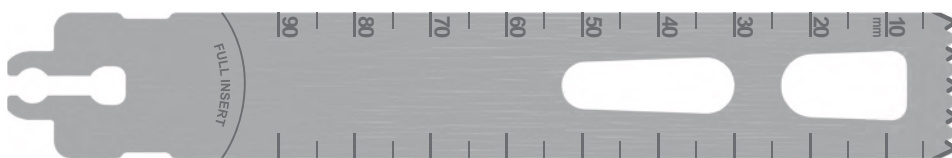

S56-522	-	95	19	2.1	1.19	1.19
----------------	---	----	----	-----	------	------



S56-528	6125-147-090	95	25	2.1	1.47	1.47
----------------	--------------	----	----	-----	------	------

All blades shown actual size (1:1). All measurements in mm.

Stryker®, Orthopower®, Cordless Driver® is a registered trademarks and System 5™, System 6™, System 7™ and System 8™ are trademarks of Stryker Corporation.



Stryker® Sterile Packed Compatible Blades

S56

Part No.	OEM Part No.	Useable Length	Blade Width	Tooth Pitch	Blade Thickness	Cut Thickness
----------	--------------	----------------	-------------	-------------	-----------------	---------------

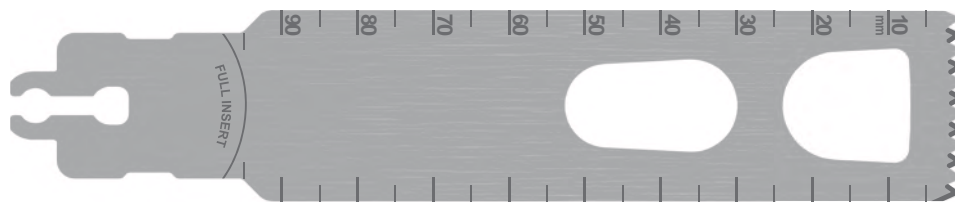

S56-529	6125-137-090	95	25	2.1	1.37	1.37
----------------	--------------	----	----	-----	------	------

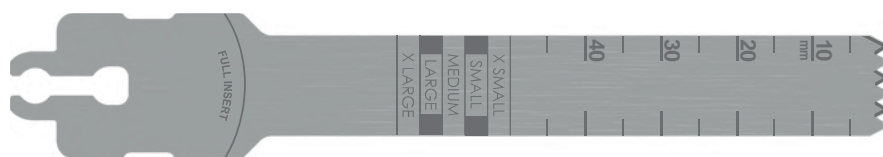

S56-561	-	85	13	2.1	0.89	0.89
----------------	---	----	----	-----	------	------



S56-585	-	110	19	2.1	1.20	1.27
----------------	---	-----	----	-----	------	------

All blades shown actual size (1:1). All measurements in mm.

Stryker®, Orthopower®, Cordless Driver® is a registered trademarks and System 5™, System 6™, System 7™ and System 8™ are trademarks of Stryker Corporation.

cm 1 2 3 4 5 6 7 8 9 10 11 12 13 14 15 16





Stryker® Sterile Packed Compatible Blades

Part No.	OEM Part No.	Useable Length	Blade Width	Tooth Pitch	Blade Thickness	Cut Thickness
----------	--------------	----------------	-------------	-------------	-----------------	---------------

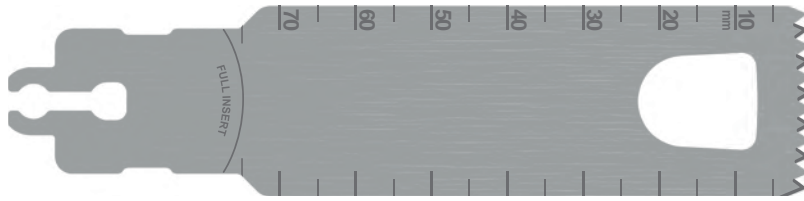

S56-6572	6125-089-075	75	25	2.1	0.89	0.89
S56-6575	-	75	25	2.1	1.19	1.19



S56-6632	6113-089-090	90	13	2.1	0.89	0.89
-----------------	--------------	----	----	-----	------	------

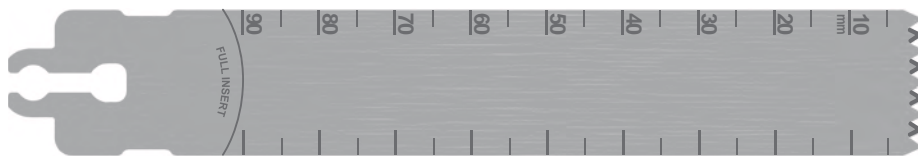

S56-6655	6118-119-090	90	18	2.1	1.19	1.19
S56-6656	6118-127-090	90	18	2.1	1.27	1.27

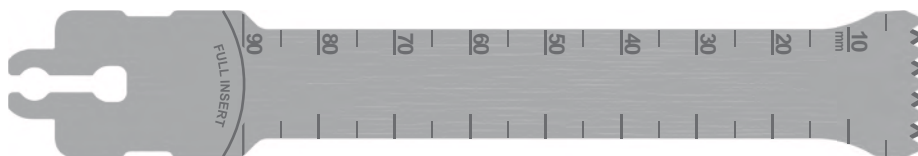

S56-9656	2108-382-3	90	18.5	2.1	1.27	1.27
S56-9657	2108-382-2	90	18.5	2.1	1.37	1.37

All blades shown actual size (1:1). All measurements in mm.

Stryker®, Orthopower®, Cordless Driver® is a registered trademarks and System 5™, System 6™, System 7™ and System 8™ are trademarks of Stryker Corporation.



Stryker® Sterile Packed Compatible Blades

S57

Part No.	OEM Part No.	Useable Length	Blade Height	Blade Thickness	Cut Thickness	Sternum Guard
----------	--------------	----------------	--------------	-----------------	---------------	---------------



S57-100	298-97-100	32	6.3	0.80	1.10	REF. OEM
----------------	------------	----	-----	------	------	----------

Stryker® Sterile Packed Compatible Blades



All blades shown actual size (1:1). All measurements in mm.

Stryker®, Orthopower®, Cordless Driver® is a registered trademarks and System 5™, System 6™, System 7™ and System 8™ are trademarks of Stryker Corporation.



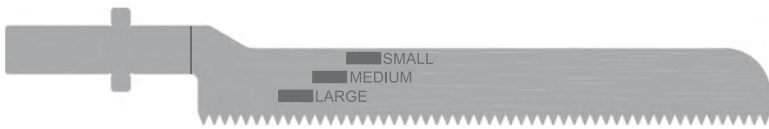

Stryker® Sterile Packed Compatible Blades

Part No.	OEM Part No.	Useable Length	Blade Height	Tooth Pitch	Blade Thickness	Cut Thickness
						
S57-275	277-96-275	70	12.5	1.3	0.64	1.00
						
S57-277	277-96-277	70	12.5	1.3	1.00	1.20
						
S57-325	277-96-325	78	11.2	1.6	0.76	1.10
						
S57-364	-	76	10	1.4	1.00	1.20

All blades shown actual size (1:1). All measurements in mm.

Stryker®, Orthopower®, Cordless Driver® is a registered trademarks and System 5™, System 6™, System 7™ and System 8™ are trademarks of Stryker Corporation.



Stryker® Sterile Packed Compatible Blades

S57

Part No.	OEM Part No.	Useable Length	Blade Height	Blade Thickness	Cut Thickness	Type
----------	--------------	----------------	--------------	-----------------	---------------	------



S57-381	-	15	14	2.93	2.93	CEMENTLESS
----------------	---	----	----	------	------	------------

All blades shown actual size (1:1). All measurements in mm.

Stryker®, Orthopower®, Cordless Driver® is a registered trademarks and System 5™, System 6™, System 7™ and System 8™ are trademarks of Stryker Corporation.





Stryker® Sterile Packed Compatible Blades

Part No.	OEM Part No.	Useable Length	Blade Width	Tooth Pitch	Blade Thickness	Cut Thickness
----------	--------------	----------------	-------------	-------------	-----------------	---------------



S59-101	2296-3-101	10	9	0.8	0.38	0.38
S59-601	2296-33-101	10	9	0.8	0.51	0.51



S59-102	2296-3-102	18.5	16.5	0.8	0.38	0.38
S59-602	2296-33-102	18.5	16.5	0.8	0.51	0.51



S59-103	2296-3-103	15	7	0.8	0.38	0.38
S59-603	2296-33-103	15	7	0.8	0.51	0.51



S59-104	2296-3-104	34.5	16.5	0.8	0.38	0.38
S59-604	2296-33-104	34.5	16.5	0.8	0.51	0.51



S59-105	2296-3-105	18.5	9	0.8	0.38	0.38
S59-605	2296-33-105	18.5	9	0.8	0.51	0.51

All blades shown actual size (1:1). All measurements in mm.

Stryker®, Orthopower®, Cordless Driver® is a registered trademarks and System 5™, System 6™, System 7™ and System 8™ are trademarks of Stryker Corporation.



Stryker® Sterile Packed Compatible Blades

S59

Part No.	OEM Part No.	Useable Length	Blade Width	Tooth Pitch	Blade Thickness	Cut Thickness
----------	--------------	----------------	-------------	-------------	-----------------	---------------



S59-106	2296-3-106	34.5	13	0.8	0.38	0.38
S59-606	2296-33-106	34.5	13	0.8	0.51	0.51



S59-108	2296-3-108	39	13	0.8	0.38	0.38
S59-608	2296-33-108	39	13	0.8	0.51	0.51



S59-111	2296-3-111	25	9	0.8	0.38	0.38
S59-611	2296-33-111	25	9	0.8	0.51	0.51



S59-114	2296-3-114	18.5	7	0.8	0.38	0.38
S59-614	2296-33-114	18.5	7	0.8	0.51	0.51



S59-115	2296-3-115	29.5	7	0.8	0.38	0.38
S59-615	2296-33-115	29.5	7	0.8	0.51	0.51

All blades shown actual size (1:1). All measurements in mm.

Stryker®, Orthopower®, Cordless Driver® is a registered trademarks and System 5™, System 6™, System 7™ and System 8™ are trademarks of Stryker Corporation.

cm 1 2 3 4 5 6 7 8 9 10 11 12 13 14 15 16





Stryker® Sterile Packed Compatible Blades

Part No.	OEM Part No.	Useable Length	Blade Width	Tooth Pitch	Blade Thickness	Cut Thickness
----------	--------------	----------------	-------------	-------------	-----------------	---------------



S59-125	2296-3-125	31	9	0.8	0.38	0.38
S59-625	2296-33-125	31	9	0.8	0.51	0.51



S59-206	2296-3-206	34.5	12	1.1	0.38	0.38
S59-706	2296-33-206	34.5	12	1.1	0.51	0.51



S59-212	2296-3-212	18	5.5	1.1	0.38	0.38
S59-712	2296-33-212	18	5.5	1.1	0.51	0.51



S59-225	2296-3-225	31	9	1.1	0.38	0.38
S59-725	2296-33-225	31	9	1.1	0.51	0.51



S59-410	2296-3-410	11.5	5.5	0.8	0.38	0.38
S59-910	2296-33-410	11.5	5.5	0.8	0.51	0.51

All blades shown actual size (1:1). All measurements in mm.

Stryker®, Orthopower®, Cordless Driver® is a registered trademarks and System 5™, System 6™, System 7™ and System 8™ are trademarks of Stryker Corporation.



Stryker® Sterile Packed Compatible Blades

S59

Part No.	OEM Part No.	Useable Length	Blade Width	Tooth Pitch	Blade Thickness	Cut Thickness
----------	--------------	----------------	-------------	-------------	-----------------	---------------



S59-911	2296-33-411	11.5	9	0.8	0.51	0.51
----------------	-------------	------	---	-----	------	------



S59-412	2296-3-412	18	5.5	0.8	0.38	0.38
S59-912	2296-33-412	18	5.5	0.8	0.51	0.51



S59-413	2296-3-413	18	2.5	0.8	0.38	0.38
S59-913	2296-33-413	18	2.5	0.8	0.51	0.51



S59-414	2296-3-414	25	5.5	0.8	0.38	0.38
S59-914	2296-33-414	25	5.5	0.8	0.51	0.51

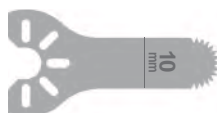

S59-951	2296-33-51	18.5	6.5	0.8	0.51	0.51
----------------	------------	------	-----	-----	------	------

All blades shown actual size (1:1). All measurements in mm.

Stryker®, Orthopower®, Cordless Driver® is a registered trademarks and System 5™, System 6™, System 7™ and System 8™ are trademarks of Stryker Corporation.





Stryker® Sterile Packed Compatible Blades

Part No.	OEM Part No.	Useable Length	Blade Width	Tooth Pitch	Blade Thickness	Cut Thickness
----------	--------------	----------------	-------------	-------------	-----------------	---------------



S59-7624	5400-3-115	30	7	1.2	0.38	0.51
-----------------	------------	----	---	-----	------	------



S59-7985	5400-003-254S1	50	19.5	1.2	0.51	0.60
-----------------	----------------	----	------	-----	------	------



S59-9268	-	15	14	1.0	0.60	0.80
-----------------	---	----	----	-----	------	------

All blades shown actual size (1:1). All measurements in mm.

Stryker®, Orthopower®, Cordless Driver® is a registered trademarks and System 5™, System 6™, System 7™ and System 8™ are trademarks of Stryker Corporation.



Zimmer[®] Sterile Packed Compatible Blades

Sagittal Saws

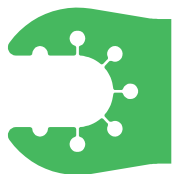

S40

Universal Power
System

Reciprocating Saws



S64

Universal Power
System

All blades shown actual size (1:1). All measurements in mm.

Zimmer[®] is a registered trademark of Zimmer Inc.

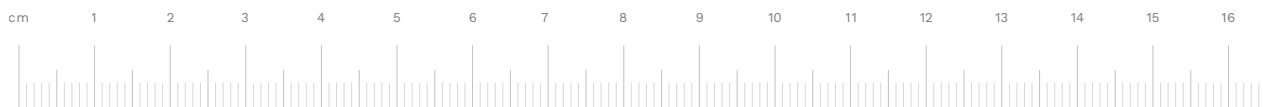

Zimmer® Sterile Packed Compatible Blades

Part No.	OEM Part No.	Useable Length	Blade Width	Tooth Pitch	Blade Thickness	Cut Thickness
----------	--------------	----------------	-------------	-------------	-----------------	---------------

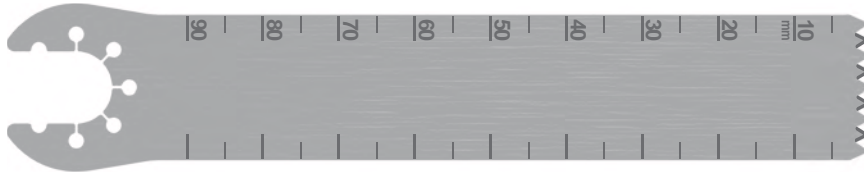

S40-004	-	90	19	2.1	1.00	1.00
----------------	---	----	----	-----	------	------

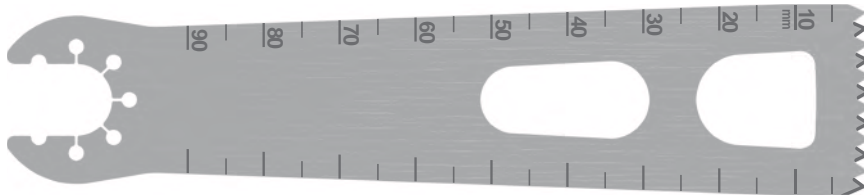

S40-005	-	90	25	2.1	1.00	1.00
----------------	---	----	----	-----	------	------

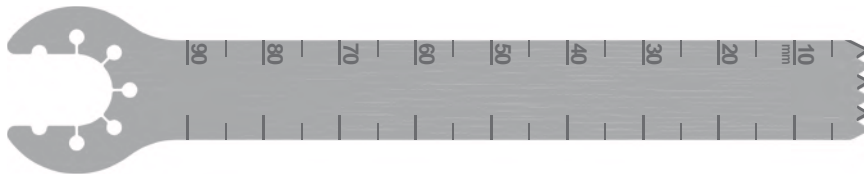

S40-006	-	90	12.5	2.1	0.90	1.00
----------------	---	----	------	-----	------	------

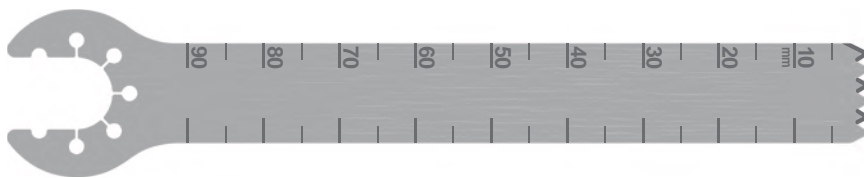

S40-007	-	90	12.5	2.1	1.27	1.27
----------------	---	----	------	-----	------	------

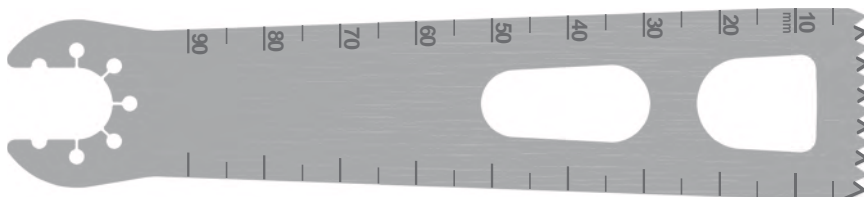

S40-008	-	90	25	2.1	0.89	0.89
----------------	---	----	----	-----	------	------

All blades shown actual size (1:1). All measurements in mm.

Zimmer® is a registered trademark of Zimmer Inc.



Zimmer® Sterile Packed Compatible Blades

S40

Part No.	OEM Part No.	Useable Length	Blade Width	Tooth Pitch	Blade Thickness	Cut Thickness
----------	--------------	----------------	-------------	-------------	-----------------	---------------

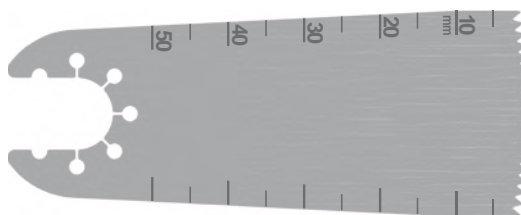

S40-010	-	49	27	1.5	0.38	0.60
----------------	---	----	----	-----	------	------

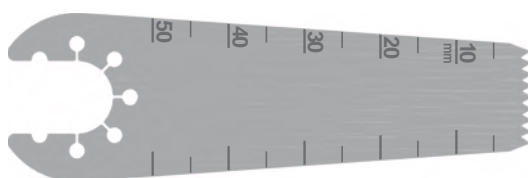

S40-015	-	49	14	1.5	0.38	0.60
----------------	---	----	----	-----	------	------

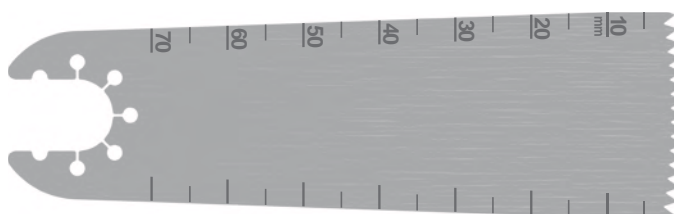

S40-017	-	69	27	1.9	0.60	0.80
----------------	---	----	----	-----	------	------

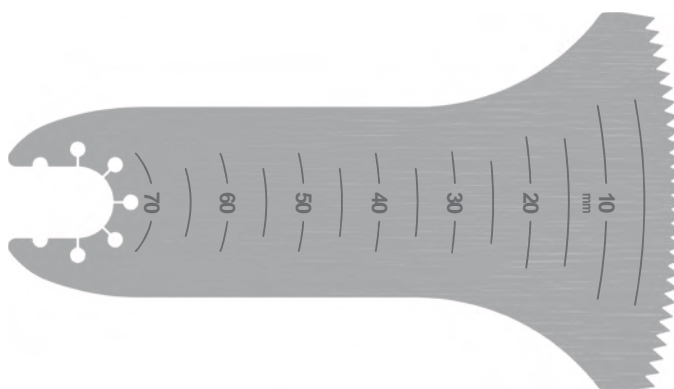

S40-019	-	69	50	1.9	0.60	0.80
----------------	---	----	----	-----	------	------

All blades shown actual size (1:1). All measurements in mm.

Zimmer® is a registered trademark of Zimmer Inc.

cm 1 2 3 4 5 6 7 8 9 10 11 12 13 14 15 16



Zimmer® Sterile Packed Compatible Blades

Part No.	OEM Part No.	Useable Length	Blade Width	Tooth Pitch	Blade Thickness	Cut Thickness
----------	--------------	----------------	-------------	-------------	-----------------	---------------

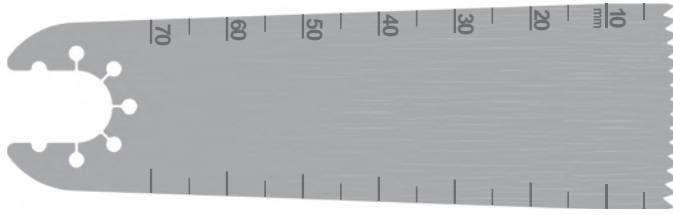

S40-020	-	69	27	1.9	0.80	1.00
----------------	---	----	----	-----	------	------

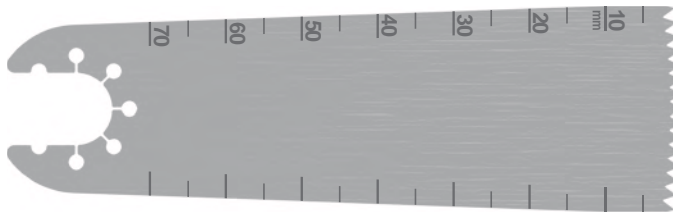

S40-021	-	69	27	1.9	1.00	1.20
----------------	---	----	----	-----	------	------

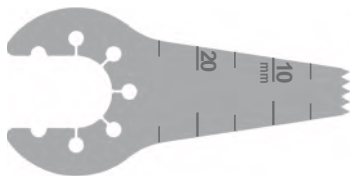

S40-023	-	25	6	1.3	0.38	0.60
----------------	---	----	---	-----	------	------

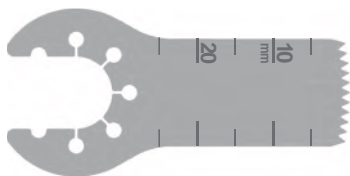

S40-025	-	25	14	1.3	0.38	0.60
----------------	---	----	----	-----	------	------

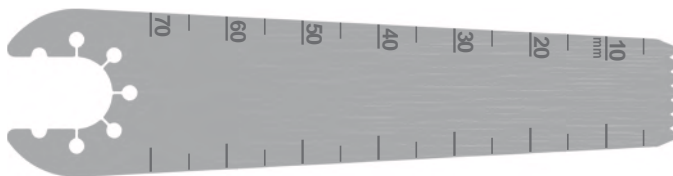

S40-057	-	70	14	1.9	0.60	0.80
----------------	---	----	----	-----	------	------

All blades shown actual size (1:1). All measurements in mm.

Zimmer® is a registered trademark of Zimmer Inc.



Zimmer® Sterile Packed Compatible Blades

S40

Part No.	OEM Part No.	Useable Length	Blade Width	Tooth Pitch	Blade Thickness	Cut Thickness
----------	--------------	----------------	-------------	-------------	-----------------	---------------

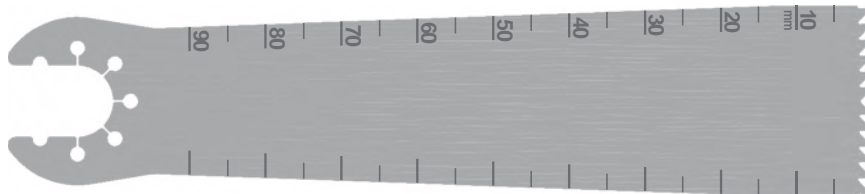

S40-200	-	90	25	2.1	0.80	0.97
----------------	---	----	----	-----	------	------

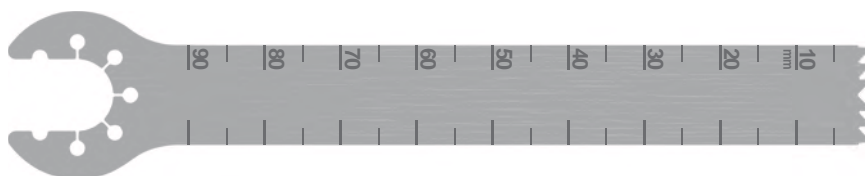

S40-201	-	90	12.5	2.1	0.89	0.89
----------------	---	----	------	-----	------	------

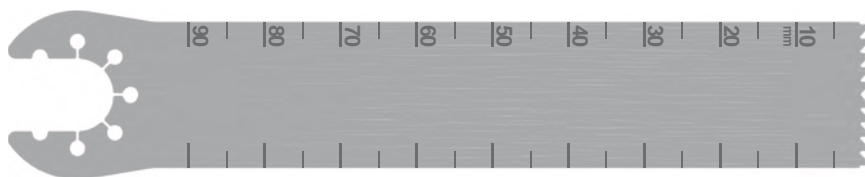

S40-205	-	90	19	1.9	1.20	1.27
----------------	---	----	----	-----	------	------

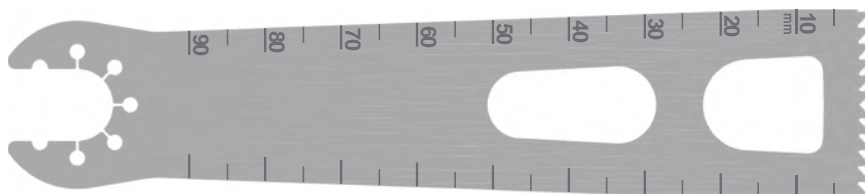

S40-206	-	90	25	2.1	1.20	1.27
----------------	---	----	----	-----	------	------

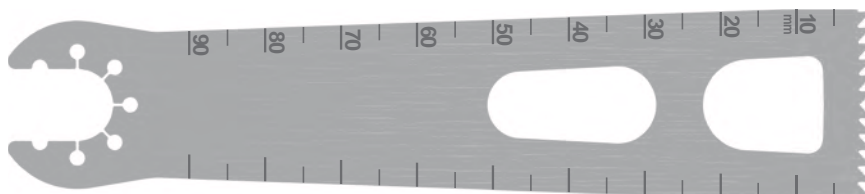

S40-209	-	90	25	2.1	1.47	1.47
----------------	---	----	----	-----	------	------

All blades shown actual size (1:1). All measurements in mm.

Zimmer® is a registered trademark of Zimmer Inc.

cm 1 2 3 4 5 6 7 8 9 10 11 12 13 14 15 16



Zimmer® Sterile Packed Compatible Blades

Part No.	OEM Part No.	Useable Length	Blade Width	Tooth Pitch	Blade Thickness	Cut Thickness
----------	--------------	----------------	-------------	-------------	-----------------	---------------

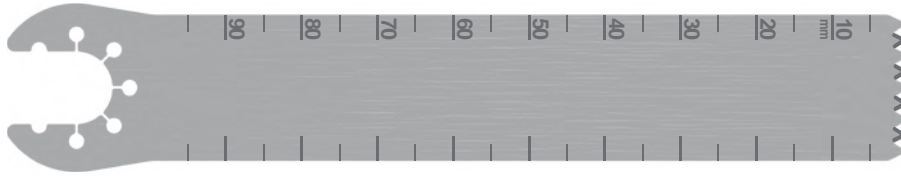

S40-513	-	95	19	2.1	1.20	1.27
----------------	---	----	----	-----	------	------

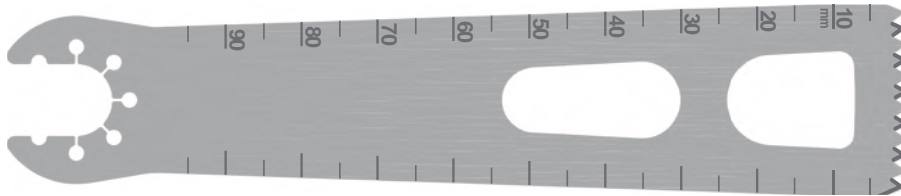

S40-516	-	95	25	2.1	1.20	1.27
----------------	---	----	----	-----	------	------

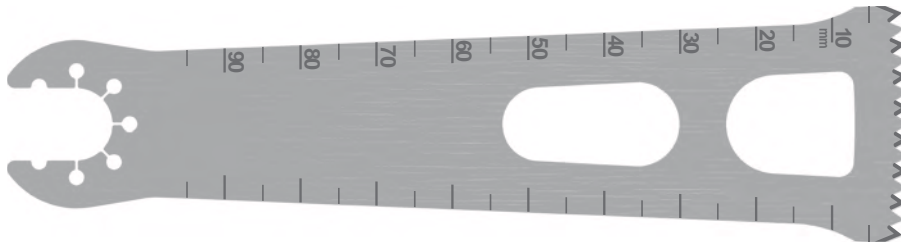

S40-518	-	95	31	2.1	1.20	1.27
----------------	---	----	----	-----	------	------

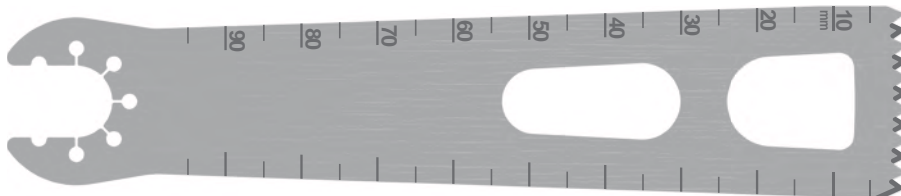

S40-528	-	95	25	2.1	1.47	1.47
----------------	---	----	----	-----	------	------

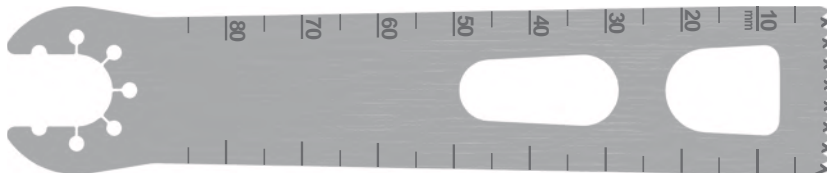

S40-530	-	85	22	1.4	0.90	1.00
----------------	---	----	----	-----	------	------

All blades shown actual size (1:1). All measurements in mm.

Zimmer® is a registered trademark of Zimmer Inc.



Zimmer® Sterile Packed Compatible Blades

S40

Part No.	OEM Part No.	Useable Length	Blade Width	Tooth Pitch	Blade Thickness	Cut Thickness
----------	--------------	----------------	-------------	-------------	-----------------	---------------

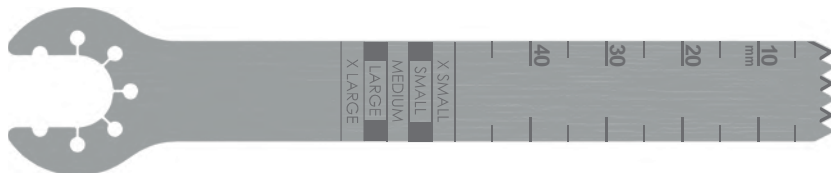

S40-561	-	85	13	2.1	0.89	0.89
----------------	---	----	----	-----	------	------

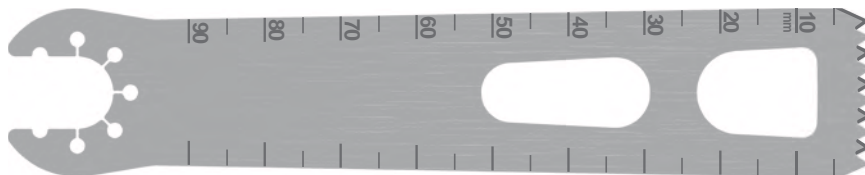

S40-571	-	90	22	2.1	1.00	1.00
----------------	---	----	----	-----	------	------

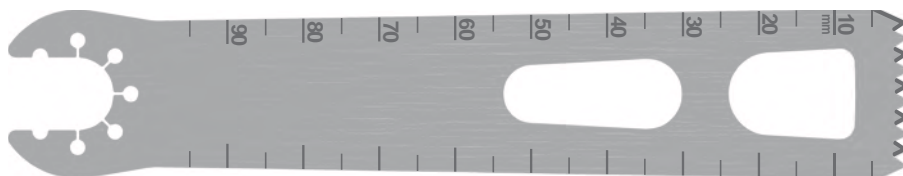

S40-575	-	95	22	2.1	1.20	1.27
----------------	---	----	----	-----	------	------

All blades shown actual size (1:1). All measurements in mm.

Zimmer® is a registered trademark of Zimmer Inc.

cm 1 2 3 4 5 6 7 8 9 10 11 12 13 14 15 16



Zimmer® Sterile Packed Compatible Blades

Part No.	OEM Part No.	Useable Length	Blade Width	Tooth Pitch	Blade Thickness	Cut Thickness
----------	--------------	----------------	-------------	-------------	-----------------	---------------

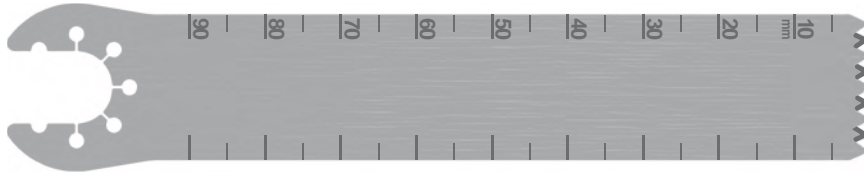

S40-6657	-	90	19	2.1	1.37	1.37
-----------------	---	----	----	-----	------	------

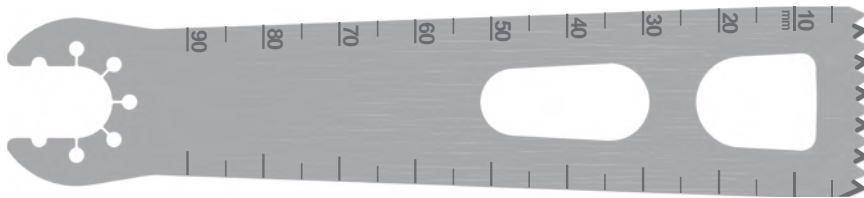

S40-6675	-	90	25	2.1	1.19	1.19
S40-6677	-	90	25	2.1	1.37	1.37

All blades shown actual size (1:1). All measurements in mm.

Zimmer® is a registered trademark of Zimmer Inc.



Zimmer® Sterile Packed Compatible Blades

S64

Part No.	OEM Part No.	Useable Length	Blade Height	Tooth Pitch	Blade Thickness	Cut Thickness
----------	--------------	----------------	--------------	-------------	-----------------	---------------



S64-358	12-0901-19U-R1	90	11.9	1.4	0.80	1.00
----------------	----------------	----	------	-----	------	------



S64-359	-	54	11.5	1.4	0.80	1.00
----------------	---	----	------	-----	------	------



S64-361	-	90	11.9	1.4	1.30	1.50
----------------	---	----	------	-----	------	------

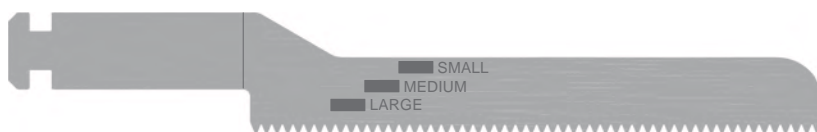

S64-364	-	76	10	1.4	1.00	1.20
----------------	---	----	----	-----	------	------



S64-373	-	71	12.5	1.3	0.80	1.00
----------------	---	----	------	-----	------	------



S64-375	13-0760-89U-R1	76	13	1.3	0.89	1.19
----------------	----------------	----	----	-----	------	------

All blades shown actual size (1:1). All measurements in mm.

Zimmer® is a registered trademark of Zimmer Inc.

cm 1 2 3 4 5 6 7 8 9 10 11 12 13 14 15 16



Smith & Nephew® Sterile Packed Compatible Blades

Sagittal Saws

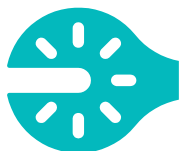

S71

Dyonics® Power

MicroAire® Sterile Packed Compatible Blades

Sagittal Saws



S78

Series 7000
SmartDriver™
SmartDriverXT



S72

Series 5000

Reciprocating Saws



S77

Series 5000
SmartDriver™
SmartDriverXT

All blades shown actual size (1:1). All measurements in mm.

Smith & Nephew® (Formerly Dyonics® Products) is a registered trademark of Smith & Nephew Inc. MicroAire® is a registered trademark of MicroAire Surgical Instruments Inc. Tuke Saw™ is a trademark of MatOrtho®

cm 1 2 3 4 5 6 7 8 9 10 11 12 13 14 15 16





Arthrex® Sterile Packed Compatible Blades

Sagittal Saws



S74

DrillSaw Mini 300™
Power System 300



S75

DrillSaw Max 600™
Power System 300

MatOrtho® Sterile Packed Compatible Blades

Sagittal Saws



S95

Tuke Saw™

All blades shown actual size (1:1). All measurements in mm.

Smith & Nephew® (Formerly Dyonics® Products) is a registered trademark of Smith & Nephew Inc. MicroAire® is a registered trademark of MicroAire Surgical Instruments Inc. Arthrex® is a registered trademark of Arthrex Inc. Tuke Saw™ is a trademark of MatOrtho®

in 1 2 3 4 5 6



Smith & Nephew® Sterile Packed Compatible Blades

Part No.	OEM Part No.	Useable Length	Blade Width	Tooth Pitch	Blade Thickness	Cut Thickness
----------	--------------	----------------	-------------	-------------	-----------------	---------------



S71-804	7205804	25.5	9.4	0.8	0.40	0.55
----------------	---------	------	-----	-----	------	------



S71-806	7205806	25.5	4.5	0.8	0.40	0.55
----------------	---------	------	-----	-----	------	------

All blades shown actual size (1:1). All measurements in mm.

Smith & Nephew® (Formerly Dyonics® Products) is a registered trademark of Smith & Nephew Inc. MicroAire® is a registered trademark of MicroAire Surgical Instruments Inc. Tuke Saw™ is a trademark of MatOrtho®

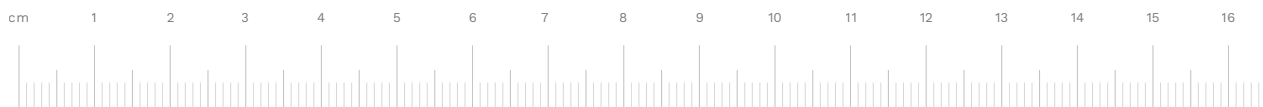



MicroAire® Sterile Packed Compatible Blades

Part No.	OEM Part No.	Useable Length	Blade Width	Tooth Pitch	Blade Thickness	Cut Thickness
----------	--------------	----------------	-------------	-------------	-----------------	---------------



S72-001	1200-001	21.5	12.7	0.7	0.30	0.50
----------------	----------	------	------	-----	------	------



S72-005	1200-005	20	6.9	0.7	0.30	0.50
----------------	----------	----	-----	-----	------	------



S72-006	1200-006	15	4.1	0.7	0.30	0.50
----------------	----------	----	-----	-----	------	------



S72-007	1200-007	15	4.3	0.8	0.30	0.50
----------------	----------	----	-----	-----	------	------



S72-009	1200-009	18	10.2	0.7	0.30	0.50
----------------	----------	----	------	-----	------	------



S72-013	1200-013	29	12.7	0.7	0.30	0.50
----------------	----------	----	------	-----	------	------

All blades shown actual size (1:1). All measurements in mm.

Smith & Nephew® (Formerly Dyonics® Products) is a registered trademark of Smith & Nephew Inc. MicroAire® is a registered trademark of MicroAire Surgical Instruments Inc. Arthrex® is a registered trademark of Arthrex Inc. Tuke Saw™ is a trademark of MatOrtho®



MicroAire® Sterile Packed Compatible Blades

S77

Part No.	OEM Part No.	Useable Length	Blade Height	Tooth Pitch	Blade Thickness	Cut Thickness
----------	--------------	----------------	--------------	-------------	-----------------	---------------



S77-001	1400-001	25.4	8	0.7	0.40	0.70
----------------	----------	------	---	-----	------	------



S77-002	1400-002	38	7	0.7	0.40	0.70
----------------	----------	----	---	-----	------	------

Smith & Nephew® / MicroAire® / Arthex® / MatOrtho® Sterile Packed Compatible Blades

All blades shown actual size (1:1). All measurements in mm.

Smith & Nephew® (Formerly Dyonics® Products) is a registered trademark of Smith & Nephew Inc. MicroAire® is a registered trademark of MicroAire Surgical Instruments Inc. Tuke Saw™ is a trademark of MatOrtho®



S7-5



MicroAire® Sterile Packed Compatible Blades

Part No.	OEM Part No.	Useable Length	Blade Width	Tooth Pitch	Blade Thickness	Cut Thickness
----------	--------------	----------------	-------------	-------------	-----------------	---------------

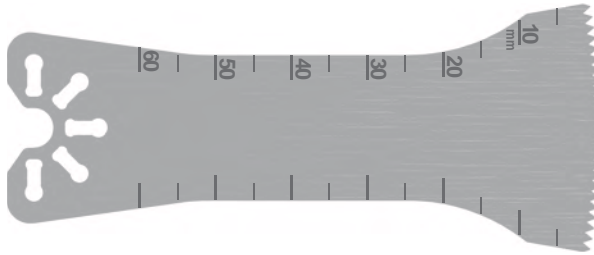

S78-051	ZO-7151	63	33.3	1.4	0.64	0.90
----------------	---------	----	------	-----	------	------

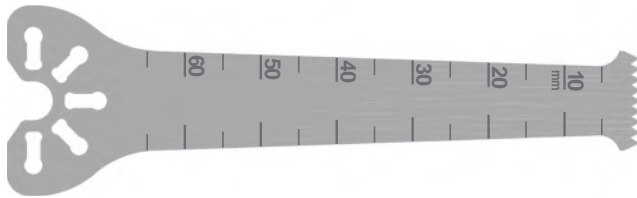

S78-052	ZO-7052	67	13	1.4	0.64	0.90
----------------	---------	----	----	-----	------	------

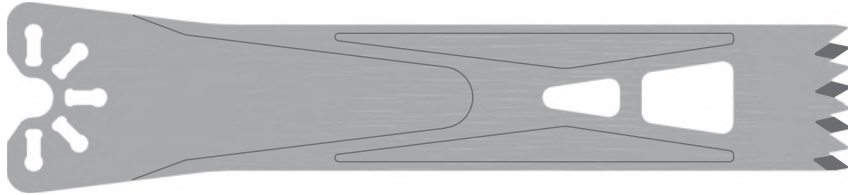

S78-123	ZO-7123	95	19.5	2.6	1.27	1.27
----------------	---------	----	------	-----	------	------



S78-145	ZO-7145	30	10.7	1.3	0.64	0.80
----------------	---------	----	------	-----	------	------

All blades shown actual size (1:1). All measurements in mm.

Smith & Nephew® (Formerly Dyonics® Products) is a registered trademark of Smith & Nephew Inc. MicroAire® is a registered trademark of MicroAire Surgical Instruments Inc. Arthrex® is a registered trademark of Arthrex Inc. Tuke Saw™ is a trademark of MatOrtho®



MicroAire® Sterile Packed Compatible Blades

S78

Smith & Nephew® / MicroAire® / Arthex® / MatOrtho® Sterile Packed Compatible Blades

Part No.	OEM Part No.	Useable Length	Blade Width	Tooth Pitch	Blade Thickness	Cut Thickness
----------	--------------	----------------	-------------	-------------	-----------------	---------------

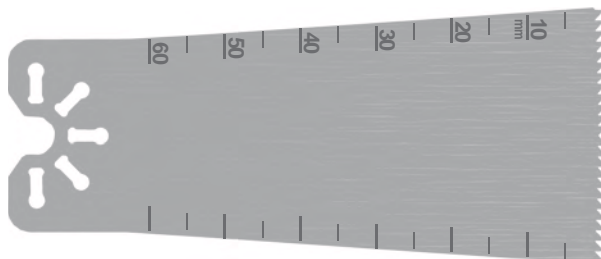

S78-156	ZO-7156	64	33.3	1.4	0.76	0.90
----------------	---------	----	------	-----	------	------

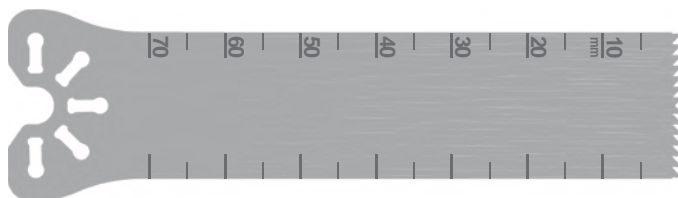

S78-172	ZO-7172	71	18	1.4	0.76	0.90
----------------	---------	----	----	-----	------	------

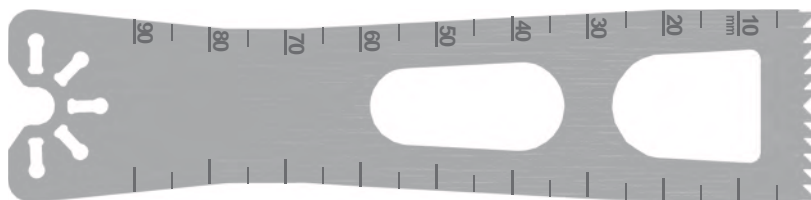

S78-206	-	90	25	2.1	1.20	1.27
----------------	---	----	----	-----	------	------

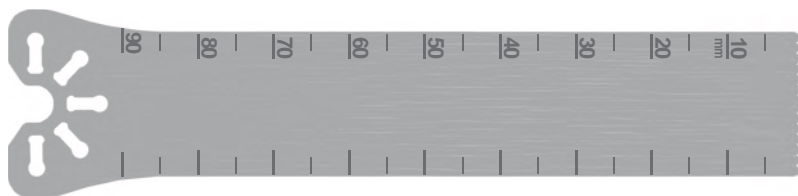

S78-274	ZO-7274	86	19.5	1.4	0.76	0.90
----------------	---------	----	------	-----	------	------

All blades shown actual size (1:1). All measurements in mm.

Smith & Nephew® (Formerly Dyonics® Products) is a registered trademark of Smith & Nephew Inc. MicroAire® is a registered trademark of MicroAire Surgical Instruments Inc. Tuke Saw™ is a trademark of MatOrtho®

cm 1 2 3 4 5 6 7 8 9 10 11 12 13 14 15 16





MicroAire® Sterile Packed Compatible Blades

Part No.	OEM Part No.	Useable Length	Blade Width	Tooth Pitch	Blade Thickness	Cut Thickness
----------	--------------	----------------	-------------	-------------	-----------------	---------------

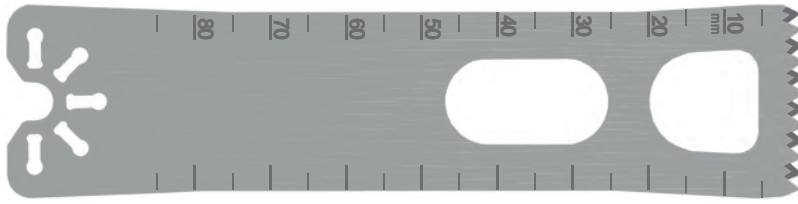

S78-556	-	90	25	2.1	0.89	0.97
----------------	---	----	----	-----	------	------

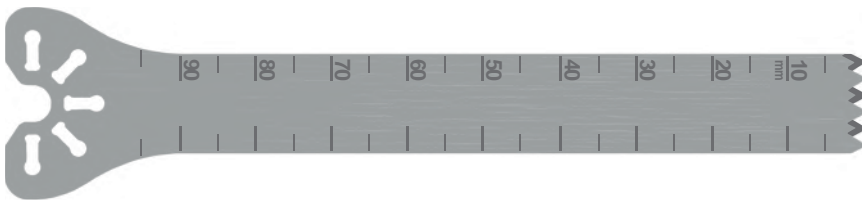

S78-654	ZO-7654	95	12.7	2.1	1.19	1.19
----------------	---------	----	------	-----	------	------

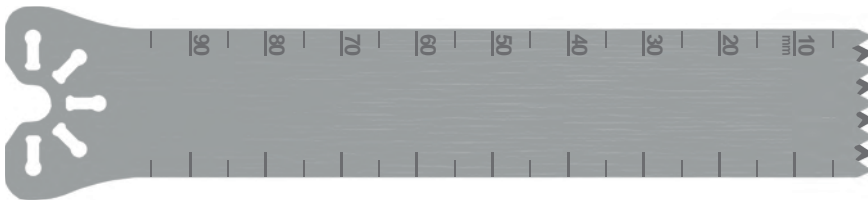

S78-682	ZO-7682	95	19.1	2.1	1.27	1.27
----------------	---------	----	------	-----	------	------

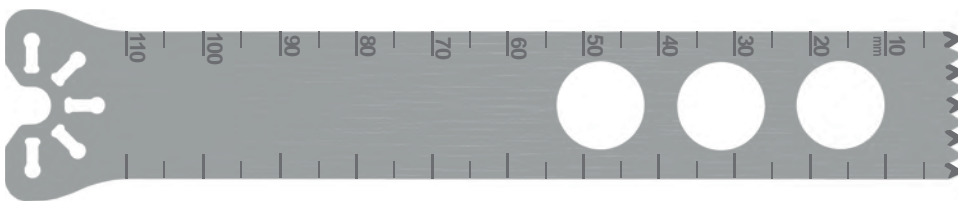

S78-685	ZO-7685	110	19.1	2.1	1.19	1.19
----------------	---------	-----	------	-----	------	------

All blades shown actual size (1:1). All measurements in mm.

Smith & Nephew® (Formerly Dyonics® Products) is a registered trademark of Smith & Nephew Inc. MicroAire® is a registered trademark of MicroAire Surgical Instruments Inc. Arthrex® is a registered trademark of Arthrex Inc. Tuke Saw™ is a trademark of MatOrtho®



MicroAire® Sterile Packed Compatible Blades

S78

Part No.	OEM Part No.	Useable Length	Blade Width	Tooth Pitch	Blade Thickness	Cut Thickness
----------	--------------	----------------	-------------	-------------	-----------------	---------------

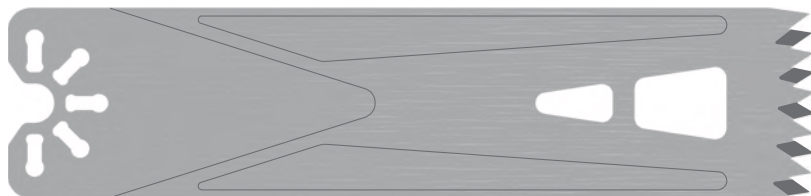

S78-3677	ZO-7163	90	25.4	2.6	1.37	1.37
-----------------	---------	----	------	-----	------	------

Smith & Nephew® / MicroAire® / Arthex® / MatOrtho® Sterile Packed Compatible Blades

All blades shown actual size (1:1). All measurements in mm.

Smith & Nephew® (Formerly Dyonics® Products) is a registered trademark of Smith & Nephew Inc. MicroAire® is a registered trademark of MicroAire Surgical Instruments Inc. Tuke Saw™ is a trademark of MatOrtho®

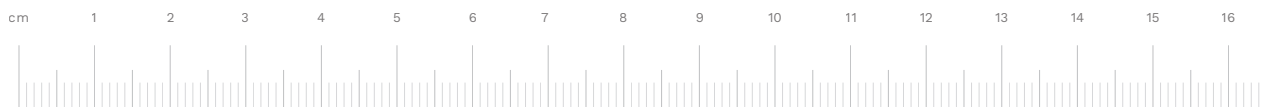



Arthrex® Sterile Packed Compatible Blades

Part No.	OEM Part No.	Useable Length	Blade Width	Tooth Pitch	Blade Thickness	Cut Thickness
----------	--------------	----------------	-------------	-------------	-----------------	---------------



S74-040	AR-300-040S	40	14	1.4	0.38	0.60
----------------	-------------	----	----	-----	------	------



S74-041	AR-300-041S	40	9.5	0.8	0.38	0.60
----------------	-------------	----	-----	-----	------	------



S74-043	AR-300-043S	25	9.5	0.6	0.38	0.60
----------------	-------------	----	-----	-----	------	------

All blades shown actual size (1:1). All measurements in mm.

Smith & Nephew® (Formerly Dyonics® Products) is a registered trademark of Smith & Nephew Inc. MicroAire® is a registered trademark of MicroAire Surgical Instruments Inc. Arthrex® is a registered trademark of Arthrex Inc. Tuke Saw™ is a trademark of MatOrtho®



Arthrex® Sterile Packed Compatible Blades

S75

Part No.	OEM Part No.	Useable Length	Blade Width	Tooth Pitch	Blade Thickness	Cut Thickness
----------	--------------	----------------	-------------	-------------	-----------------	---------------

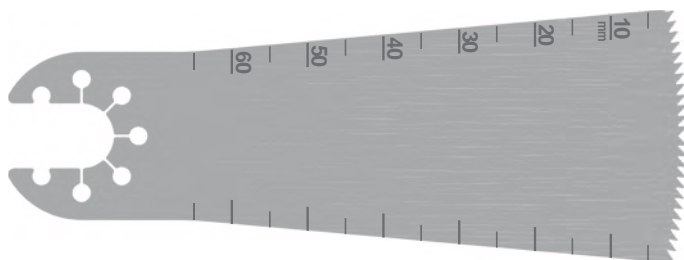

S75-2483	-	65	33	1.4	0.90	0.97
-----------------	---	----	----	-----	------	------

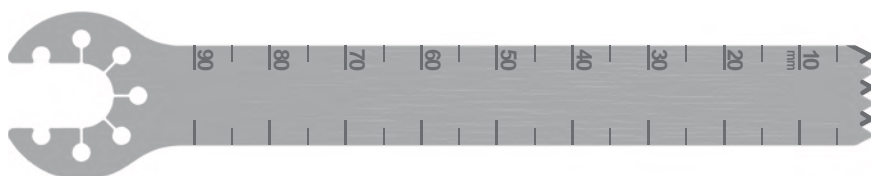

S75-6636	AR-600-001S	90	13	2.1	1.27	1.27
-----------------	-------------	----	----	-----	------	------



S75-6656	AR-600-002S	90	19	2.1	1.27	1.27
-----------------	-------------	----	----	-----	------	------

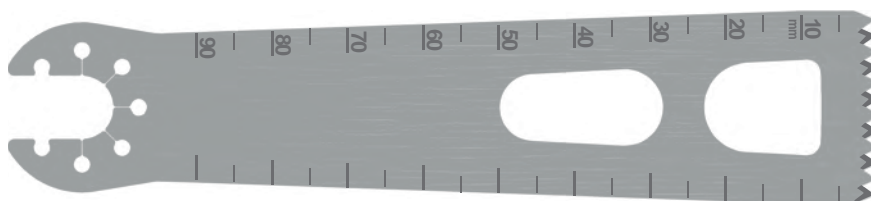

S75-6676	AR-600-005S	90	25.4	2.1	1.27	1.27
-----------------	-------------	----	------	-----	------	------

All blades shown actual size (1:1). All measurements in mm.

Smith & Nephew® (Formerly Dyonics® Products) is a registered trademark of Smith & Nephew Inc. MicroAire® is a registered trademark of MicroAire Surgical Instruments Inc. Tuke Saw™ is a trademark of MatOrtho®

cm 1 2 3 4 5 6 7 8 9 10 11 12 13 14 15 16





MatOrtho® Sterile Packed Compatible Blades

Part No.	OEM Part No.	Useable Length	Blade Width	Tooth Pitch	Blade Thickness	Cut Thickness
----------	--------------	----------------	-------------	-------------	-----------------	---------------

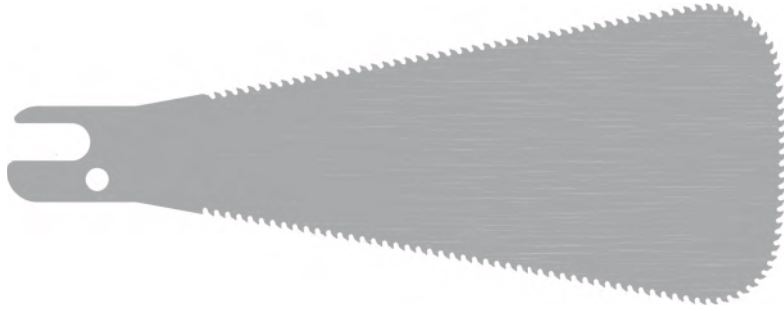

S95-100	-	90	39	1.5	0.70	0.70
----------------	---	----	----	-----	------	------



S95-101	-	70	12.4	1.4	0.80	1.20
----------------	---	----	------	-----	------	------

All blades shown actual size (1:1). All measurements in mm.

Smith & Nephew® (Formerly Dyonics® Products) is a registered trademark of Smith & Nephew Inc. MicroAire® is a registered trademark of MicroAire Surgical Instruments Inc. Arthrex® is a registered trademark of Arthrex Inc. Tuke Saw™ is a trademark of MatOrtho®



De Soutter® Sterile Packed Blades

Sagittal Saws



S89

DBK-701
KQ-707

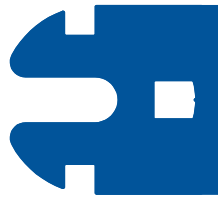

S87

DBK-700
DPX-676
KX-600



S88-1XX

NQ-700/707
NU-470
NZ-450
NI-270
NV-220



S88-4XX

DBN-470
NU-471



S86-XXXX

SU-471/2
SI-270
OI-270



S85

SU-470
SZ-450
SV-220



S92

D33-100

All blades shown actual size (1:1). All measurements in mm.

cm 1 2 3 4 5 6 7 8 9 10 11 12 13 14 15 16

De Soutter® Sterile Packed Blades

Reciprocating
Saws



S84-3XX

DBC-700
CQ-700/707/710



S22

CU-471
CZ-450
CQ-711



S83-XXXX

CI-270



S92

CU-470
CI-271
CZ-451
CV-220
D34-100

Sternum
Saws



S87

DBR-700



S81 & S82

OQ-709
DPX-170



S88-9XX

DBR-470
NQ-709



S84-4XX

DBC-470
DPC-470

All blades shown actual size (1:1). All measurements in mm.

in 1 2 3 4 5 6

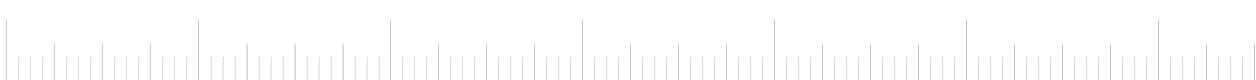

De Soutter® Sterile Packed Blades

S08

Part No.	OEM Part No.	Useable Length	Blade Height/Width	Blade Thickness	Cut Thickness	Type
S08-001	PROCEDURE PACK - 3 PACK - OXFORD CEMENTLESS - DE SOUTTER S22 & S87					



S22-381	-	15	14	2.93	2.93	CEMENTLESS
----------------	---	----	----	------	------	------------

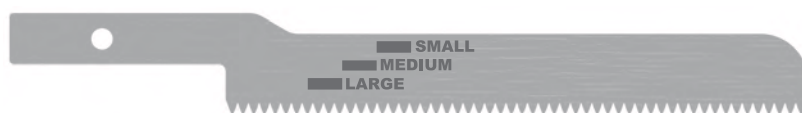

S22-364	-	76	10	1.00	1.20	-
----------------	---	----	----	------	------	---

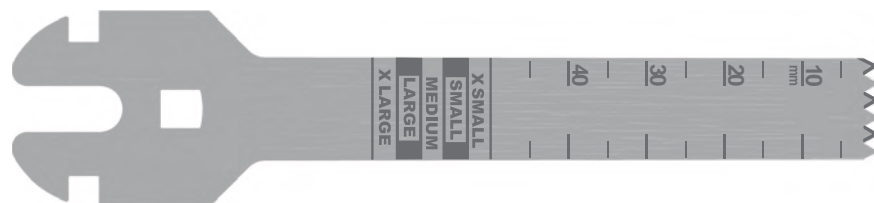

S87-561	-	85	13	0.89	0.89	-
----------------	---	----	----	------	------	---

All blades shown actual size (1:1). All measurements in mm.



De Soutter® Sterile Packed Blades

Part No.	OEM Part No.	Useable Length	Blade Height/Width	Blade Thickness	Cut Thickness	Type
----------	--------------	----------------	--------------------	-----------------	---------------	------

S08-002	PROCEDURE PACK - 3 PACK - OXFORD CEMENTLESS - DE SOUTTER S84 & S87					
----------------	--	--	--	--	--	--



S84-381	-	15	14	2.93	2.93	CEMENTLESS
----------------	---	----	----	------	------	------------

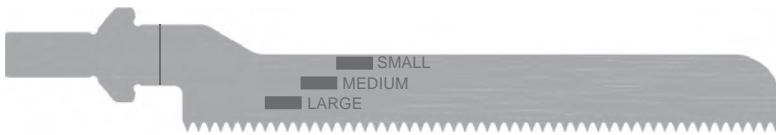

S84-364	-	76	10	1.00	1.20	-
----------------	---	----	----	------	------	---



S87-561	-	85	13	0.89	0.89	-
----------------	---	----	----	------	------	---

All blades shown actual size (1:1). All measurements in mm.



De Soutter® Sterile Packed Blades

Part No.	OEM Part No.	Useable Length	Blade Height/Width	Blade Thickness	Cut Thickness	Type
S08-003	PROCEDURE PACK - 3 PACK - OXFORD CEMENTLESS - DE SOUTTER S84 & S89					

S08



S84-381	-	15	14	2.93	2.93	CEMENTLESS
----------------	---	----	----	------	------	------------

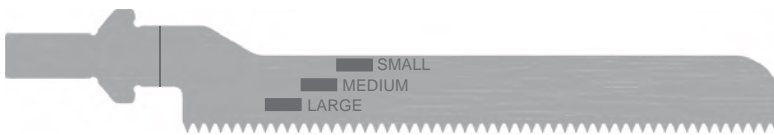

S84-364	-	76	10	1.00	1.20	-
----------------	---	----	----	------	------	---

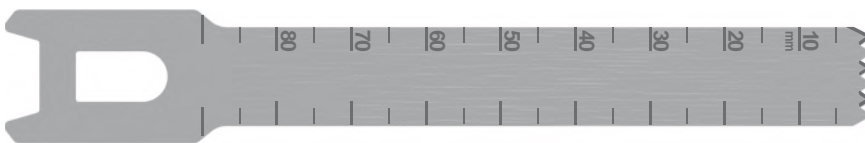

S89-6632	-	90	13	0.89	0.89	-
-----------------	---	----	----	------	------	---

All blades shown actual size (1:1). All measurements in mm.

cm 1 2 3 4 5 6 7 8 9 10 11 12 13 14 15 16



De Soutter® Sterile Packed Blades

Part No.	Useable Length	Blade Width	Tooth Pitch	Blade Thickness	Cut Thickness
----------	----------------	-------------	-------------	-----------------	---------------



S22-058	89	12.5	1.4	0.60	1.00
----------------	----	------	-----	------	------



S22-059	54.5	9.4	1.4	0.60	1.00
----------------	------	-----	-----	------	------



S22-060	38	9.4	1.1	0.40	0.60
----------------	----	-----	-----	------	------



S22-061	89	12.5	1.4	1.50	1.60
----------------	----	------	-----	------	------



S22-063	54.5	9.4	1.4	1.30	1.70
----------------	------	-----	-----	------	------



S22-273	73.5	12.5	1.3	0.80	1.00
----------------	------	------	-----	------	------



S22-275	80	12.5	1.3	1.00	1.20
----------------	----	------	-----	------	------

All blades shown actual size (1:1). All measurements in mm.



De Soutter® Sterile Packed Blades

S22

Part No.	Useable Length	Blade Width	Tooth Pitch	Blade Thickness	Cut Thickness
----------	----------------	-------------	-------------	-----------------	---------------

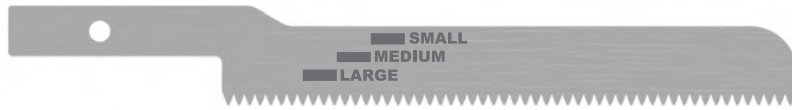

S22-364	76	10	1.4	1.00	1.20
----------------	----	----	-----	------	------

All blades shown actual size (1:1). All measurements in mm.



De Soutter® Sterile Packed Blades

Part No.	Useable Length	Blade Height	Blade Thickness	Cut Thickness	Type
----------	----------------	--------------	-----------------	---------------	------



S22-381	15	14	2.93	2.93	CEMENTLESS
----------------	----	----	------	------	------------

All blades shown actual size (1:1). All measurements in mm.



De Soutter® Sterile Packed Blades

S81

Part No.	Useable Length	Diameter	Tooth Pitch	Blade Thickness	Cut Thickness
----------	----------------	----------	-------------	-----------------	---------------



S81-101	23	64	1.6	0.46	1.00
----------------	----	----	-----	------	------



S81-102	29	76	1.4	0.46	1.00
----------------	----	----	-----	------	------

All blades shown actual size (1:1). All measurements in mm.



De Soutter® Sterile Packed Blades

Part No.	Useable Length	Diameter	Tooth Pitch	Blade Thickness	Cut Thickness
----------	----------------	----------	-------------	-----------------	---------------

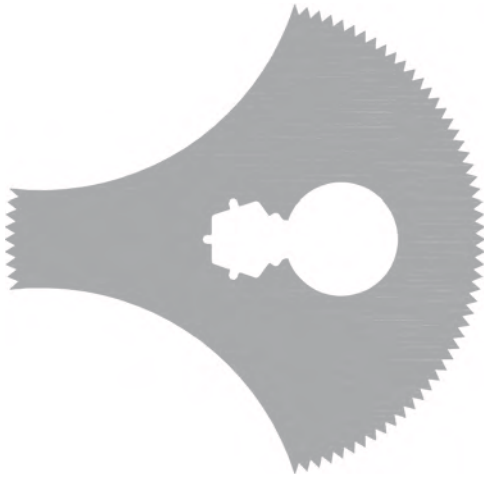

S81-105	23	64	1.6	0.46	1.00
----------------	----	----	-----	------	------



S81-106	16.5	51	1.6	0.50	1.00
----------------	------	----	-----	------	------

All blades shown actual size (1:1). All measurements in mm.



De Soutter® Sterile Packed Blades

S81

Part No.	Useable Length	Blade Width	Tooth Pitch	Blade Thickness	Cut Thickness
----------	----------------	-------------	-------------	-----------------	---------------

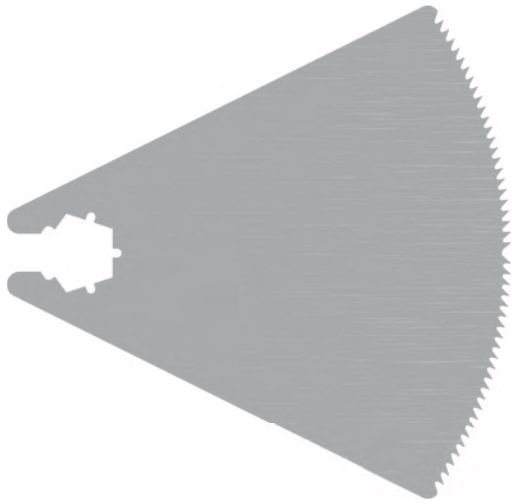

S81-200	48	66	1.4	0.50	1.00
----------------	----	----	-----	------	------



S81-201	23	63	1.3	0.50	1.00
----------------	----	----	-----	------	------

All blades shown actual size (1:1). All measurements in mm.



De Soutter® Sterile Packed Blades

Part No.	Useable Length	Blade Width	Tooth Pitch	Blade Thickness	Cut Thickness
----------	----------------	-------------	-------------	-----------------	---------------

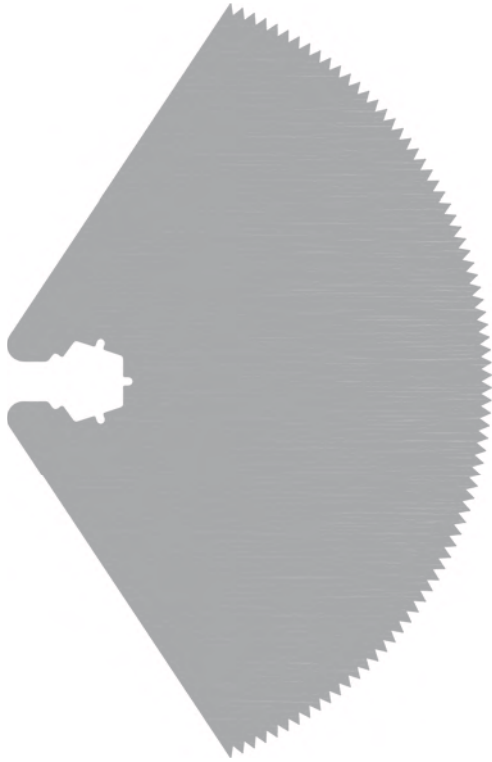

S81-202	41	93	1.6	0.50	1.00
----------------	----	----	-----	------	------

All blades shown actual size (1:1). All measurements in mm.



De Soutter® Sterile Packed Blades

Part No.	Useable Length	Blade Width	Tooth Pitch	Blade Thickness	Cut Thickness
----------	----------------	-------------	-------------	-----------------	---------------



S82-100	42	13	1.6	0.46	0.90
----------------	----	----	-----	------	------



S82-101	42	25	1.6	0.46	0.90
----------------	----	----	-----	------	------

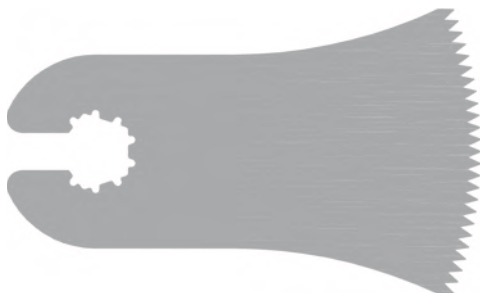

S82-102	42	38	1.6	0.46	0.90
----------------	----	----	-----	------	------

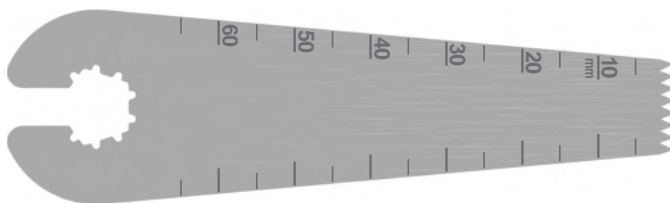

S82-103	67	12	1.6	0.80	1.20
----------------	----	----	-----	------	------

All blades shown actual size (1:1). All measurements in mm.

cm 1 2 3 4 5 6 7 8 9 10 11 12 13 14 15 16





De Soutter® Sterile Packed Blades

Part No.	Useable Length	Blade Width	Tooth Pitch	Blade Thickness	Cut Thickness
----------	----------------	-------------	-------------	-----------------	---------------



S82-104	67	25	1.6	0.80	1.20
----------------	----	----	-----	------	------

All blades shown actual size (1:1). All measurements in mm.



De Soutter® Sterile Packed Blades

S83

Part No.	Useable Length	Blade Height	Tooth Pitch	Blade Thickness	Cut Thickness	Extension Length
----------	----------------	--------------	-------------	-----------------	---------------	------------------



S83-0325	20	6.4	1.1	0.38	0.60	19.5
-----------------	----	-----	-----	------	------	------



S83-0405	25.5	7.6	1.1	0.38	0.60	0.0
-----------------	------	-----	-----	------	------	-----



S83-0428	25.5	7.6	1.1	0.60	0.80	19.5
-----------------	------	-----	-----	------	------	------



S83-0605	38	7.6	1.1	0.38	0.60	0.0
-----------------	----	-----	-----	------	------	-----



S83-1155	14.5	4	1.3	0.38	0.60	31.5
-----------------	------	---	-----	------	------	------



S83-1428	27	6.4	1.3	0.60	0.80	19.5
-----------------	----	-----	-----	------	------	------



S83-1528	33.5	6.4	1.3	0.60	0.80	19.5
-----------------	------	-----	-----	------	------	------



S83-4425	25.5	8.7	0.8	0.38	0.60	19.5
-----------------	------	-----	-----	------	------	------

All blades shown actual size (1:1). All measurements in mm.

cm 1 2 3 4 5 6 7 8 9 10 11 12 13 14 15 16



De Soutter® Sterile Packed Blades

Part No.	Useable Length	Blade Height	Tooth Pitch	Blade Thickness	Cut Thickness
----------	----------------	--------------	-------------	-----------------	---------------



S84-358	90	8	1.4	0.60	1.00
----------------	----	---	-----	------	------



S84-359	54	8	1.4	0.60	1.00
----------------	----	---	-----	------	------



S84-360	80	8	1.4	0.80	1.10
----------------	----	---	-----	------	------



S84-361	90	8	1.4	1.30	1.50
----------------	----	---	-----	------	------



S84-363	54	8	1.4	1.30	1.50
----------------	----	---	-----	------	------

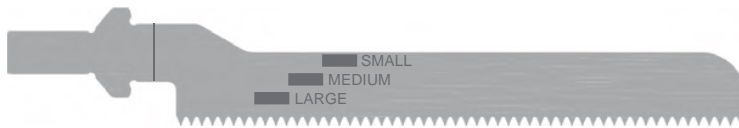

S84-364	76	10	1.4	1.00	1.20
----------------	----	----	-----	------	------

All blades shown actual size (1:1). All measurements in mm.



De Soutter® Sterile Packed Blades

Part No.	Useable Length	Blade Height	Tooth Pitch	Blade Thickness	Cut Thickness
----------	----------------	--------------	-------------	-----------------	---------------



S84-373	71	12	1.3	0.80	1.00
----------------	----	----	-----	------	------



S84-375	80	12	1.3	1.00	1.20
----------------	----	----	-----	------	------

S84

All blades shown actual size (1:1). All measurements in mm.

cm 1 2 3 4 5 6 7 8 9 10 11 12 13 14 15 16





De Soutter® Sterile Packed Blades

Part No.	Useable Length	Blade Height	Blade Thickness	Cut Thickness	Type
----------	----------------	--------------	-----------------	---------------	------



S84-381	15	14	2.93	2.93	CEMENTLESS
----------------	----	----	------	------	------------

All blades shown actual size (1:1). All measurements in mm.



De Soutter® Sterile Packed Blades

S84

Part No.	Useable Length	Blade Height	Tooth Pitch	Blade Thickness	Cut Thickness	Tooth Type
----------	----------------	--------------	-------------	-----------------	---------------	------------



S84-400	35	7	1.4	0.80	1.20	Uni directional cut
----------------	----	---	-----	------	------	---------------------



S84-401	35	7	1.4	0.80	1.20	Bi directional cut
----------------	----	---	-----	------	------	--------------------



S84-402	35	7	1.4	0.60	1.20	Uni directional cut
----------------	----	---	-----	------	------	---------------------

All blades shown actual size (1:1). All measurements in mm.



De Soutter® Sterile Packed Blades

Part No.	Useable Length	Blade Width	Tooth Pitch	Blade Thickness	Cut Thickness
----------	----------------	-------------	-------------	-----------------	---------------

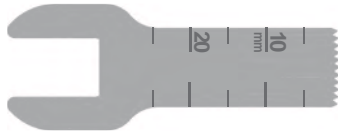

S85-100	23	10	1.0	0.38	0.70
----------------	----	----	-----	------	------



S85-101	22	10	1.1	0.38	0.70
----------------	----	----	-----	------	------

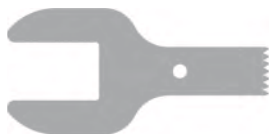

S85-102	16	6	1.1	0.38	0.70
----------------	----	---	-----	------	------



S85-103	22	6	1.1	0.38	0.70
----------------	----	---	-----	------	------



S85-104	16	10	1.1	0.38	0.70
----------------	----	----	-----	------	------



S85-105	25	4	0.8	0.38	0.70
----------------	----	---	-----	------	------

All blades shown actual size (1:1). All measurements in mm.



De Soutter® Sterile Packed Blades

S85

Part No.	Useable Length	Blade Width	Tooth Pitch	Blade Thickness	Cut Thickness
----------	----------------	-------------	-------------	-----------------	---------------



S85-106	22	19	1.1	0.38	0.70
----------------	----	----	-----	------	------



S85-107	46	19	1.1	0.38	0.70
----------------	----	----	-----	------	------



S85-108	22	15	1.1	0.38	0.70
----------------	----	----	-----	------	------



S85-109	46	15	1.1	0.38	0.70
----------------	----	----	-----	------	------



S85-110	35	10	1.4	0.38	0.70
----------------	----	----	-----	------	------



S85-111	10	10	1.1	0.38	0.70
----------------	----	----	-----	------	------

All blades shown actual size (1:1). All measurements in mm.

cm 1 2 3 4 5 6 7 8 9 10 11 12 13 14 15 16



De Soutter® Sterile Packed Blades

Part No.	Useable Length	Blade Width	Tooth Pitch	Blade Thickness	Cut Thickness
----------	----------------	-------------	-------------	-----------------	---------------



S85-115	25	7	0.8	0.38	0.43
----------------	----	---	-----	------	------



S85-118	22	9.5	0.8	0.38	0.60
----------------	----	-----	-----	------	------



S85-124	33	9	0.8	0.38	0.38
----------------	----	---	-----	------	------



S85-125	25	9	0.8	0.38	0.43
----------------	----	---	-----	------	------



S85-150	25	10	1.0	0.70	1.00
----------------	----	----	-----	------	------



S85-151	25	10	1.1	0.70	1.00
----------------	----	----	-----	------	------

All blades shown actual size (1:1). All measurements in mm.



De Soutter® Sterile Packed Blades

S85

Part No.	Useable Length	Blade Width	Tooth Pitch	Blade Thickness	Cut Thickness
----------	----------------	-------------	-------------	-----------------	---------------



S85-152	16	6	1.1	0.70	1.00
----------------	----	---	-----	------	------



S85-153	22	6	1.1	0.70	1.00
----------------	----	---	-----	------	------

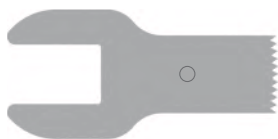

S85-154	16	10	1.1	0.70	1.00
----------------	----	----	-----	------	------



S85-156	22	10	1.1	0.70	1.00
----------------	----	----	-----	------	------



S85-157	46	19	1.4	0.70	0.90
----------------	----	----	-----	------	------



S85-158	22	15	1.4	0.70	0.90
----------------	----	----	-----	------	------

All blades shown actual size (1:1). All measurements in mm.

cm 1 2 3 4 5 6 7 8 9 10 11 12 13 14 15 16



De Soutter® Sterile Packed Blades

Part No.	Useable Length	Blade Width	Tooth Pitch	Blade Thickness	Cut Thickness
----------	----------------	-------------	-------------	-----------------	---------------



S85-159	46	15	1.4	0.70	0.90
----------------	----	----	-----	------	------

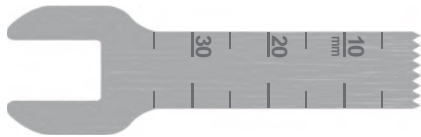

S85-160	35	10	1.4	0.70	0.90
----------------	----	----	-----	------	------



S85-162	30	6	1.1	0.70	1.00
----------------	----	---	-----	------	------



S85-163	46	10	1.4	0.70	0.90
----------------	----	----	-----	------	------

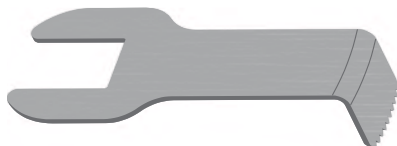

S85-176	10	10	1.0	0.70	1.00
----------------	----	----	-----	------	------

All blades shown actual size (1:1). All measurements in mm.



De Soutter® Sterile Packed Blades

Part No.	Useable Length	Blade Width	Tooth Pitch	Blade Thickness	Cut Thickness
----------	----------------	-------------	-------------	-----------------	---------------



S85-180	15	14	1.0	0.70	1.00
----------------	----	----	-----	------	------

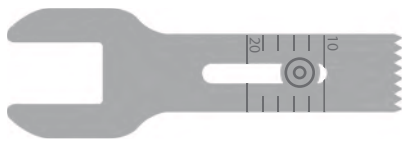

S85-200	10 to 20	10	1.4	0.60	0.80
----------------	----------	----	-----	------	------

All blades shown actual size (1:1). All measurements in mm.



S85

De Soutter® Sterile Packed Blades

S8-25

De Soutter® Sterile Packed Blades

Part No.	Useable Length	Blade Width	Tooth Pitch	Blade Thickness	Cut Thickness
----------	----------------	-------------	-------------	-----------------	---------------



S86-0312	18	5.5	0.8	0.38	0.38
S86-0315	18	5.5	0.8	0.38	0.60



S86-0322	18	7	0.8	0.38	0.38
-----------------	----	---	-----	------	------



S86-0512	25	5.5	0.8	0.38	0.38
S86-0515	25	5.5	0.8	0.38	0.60



S86-0532	25	9	0.8	0.38	0.38
S86-0534	25	9	0.8	0.51	0.51
S86-0535	25	9	0.8	0.38	0.60



S86-0622	30	7	0.8	0.38	0.38
S86-0624	30	7	0.8	0.51	0.51

All blades shown actual size (1:1). All measurements in mm.



De Soutter® Sterile Packed Blades

S86

Part No.	Useable Length	Blade Width	Tooth Pitch	Blade Thickness	Cut Thickness
----------	----------------	-------------	-------------	-----------------	---------------



S86-0632	30	9	0.8	0.38	0.38
S86-0634	30	9	0.8	0.51	0.51



S86-0715	35	5.5	0.8	0.38	0.60
-----------------	----	-----	-----	------	------



S86-0835	40	9	0.8	0.38	0.60
-----------------	----	---	-----	------	------



S86-1225	15	7	1.1	0.38	0.60
-----------------	----	---	-----	------	------



S86-1425	21	7	1.1	0.38	0.60
-----------------	----	---	-----	------	------



S86-1435	21	9	1.1	0.38	0.60
-----------------	----	---	-----	------	------

All blades shown actual size (1:1). All measurements in mm.

cm 1 2 3 4 5 6 7 8 9 10 11 12 13 14 15 16



De Soutter® Sterile Packed Blades

Part No.	Useable Length	Blade Width	Tooth Pitch	Blade Thickness	Cut Thickness
----------	----------------	-------------	-------------	-----------------	---------------



S86-1515	25	5.5	1.4	0.38	0.60
-----------------	----	-----	-----	------	------



S86-1535	25	9	1.4	0.38	0.60
-----------------	----	---	-----	------	------



S86-1555	25	13	1.4	0.38	0.60
-----------------	----	----	-----	------	------



S86-1632	30	9	1.1	0.38	0.38
-----------------	----	---	-----	------	------



S86-1735	35	9	1.4	0.38	0.60
-----------------	----	---	-----	------	------





S86-1855	40	13	1.4	0.38	0.60
-----------------	----	----	-----	------	------

All blades shown actual size (1:1). All measurements in mm.



De Soutter® Sterile Packed Blades

Part No.	Useable Length	Blade Width	Tooth Pitch	Blade Thickness	Cut Thickness
	40	19	1.4	0.38	0.60
	40	9	0.8	0.38	0.60
	25	5.5	1.4	0.38	0.60

S86

All blades shown actual size (1:1). All measurements in mm.



De Soutter® Sterile Packed Blades

Part No.	Useable Length	Blade Width	Tooth Pitch	Blade Thickness	Cut Thickness
----------	----------------	-------------	-------------	-----------------	---------------

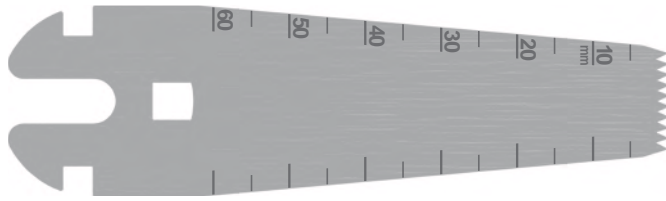

S87-050	60	14	1.4	0.38	0.60
----------------	----	----	-----	------	------

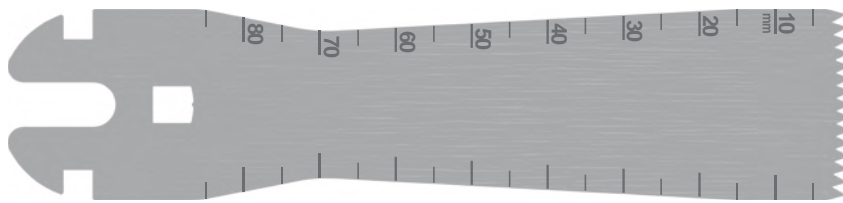

S87-100	85	25	1.7	0.80	1.00
----------------	----	----	-----	------	------

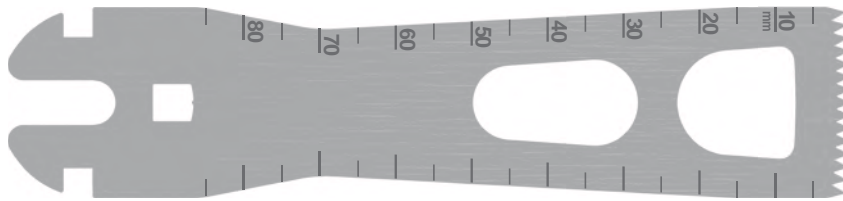

S87-101	85	25	1.7	1.20	1.27
----------------	----	----	-----	------	------

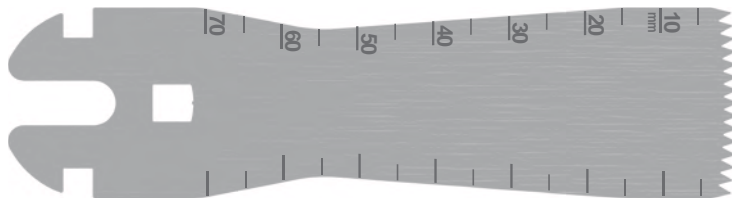

S87-102	70	25	1.7	0.80	1.00
----------------	----	----	-----	------	------

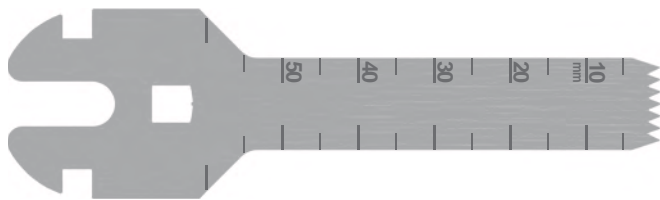

S87-103	60	12	1.6	0.60	0.80
----------------	----	----	-----	------	------

All blades shown actual size (1:1). All measurements in mm.



De Soutter® Sterile Packed Blades

S87

Part No.	Useable Length	Blade Width	Tooth Pitch	Blade Thickness	Cut Thickness
----------	----------------	-------------	-------------	-----------------	---------------

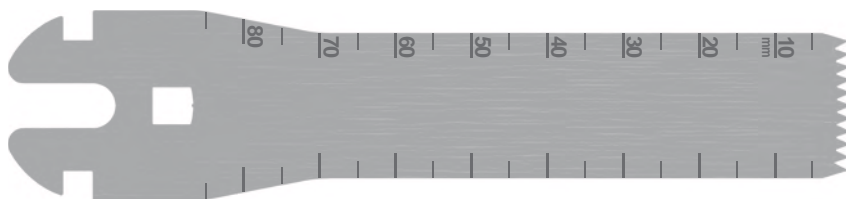

S87-104	85	19	1.7	0.80	1.00
----------------	----	----	-----	------	------

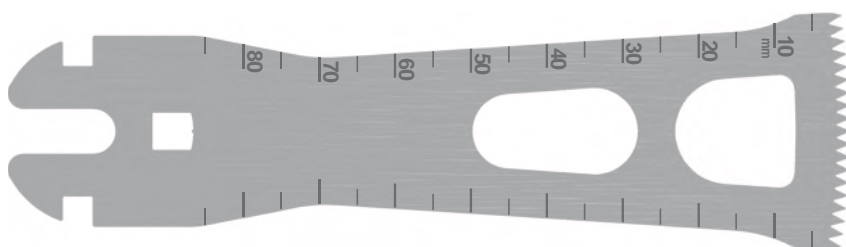

S87-105	85	31	1.7	1.20	1.27
----------------	----	----	-----	------	------



S87-106	75	25	1.7	0.60	0.80
----------------	----	----	-----	------	------

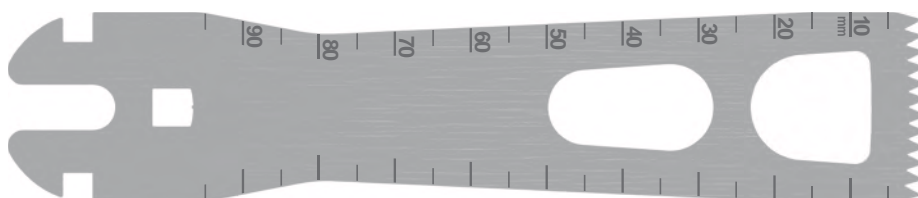

S87-107	95	25	2.1	1.20	1.27
----------------	----	----	-----	------	------

All blades shown actual size (1:1). All measurements in mm.

cm 1 2 3 4 5 6 7 8 9 10 11 12 13 14 15 16



De Soutter® Sterile Packed Blades

Part No.	Useable Length	Blade Width	Tooth Pitch	Blade Thickness	Cut Thickness
----------	----------------	-------------	-------------	-----------------	---------------

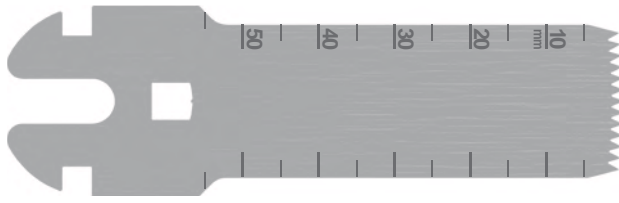

S87-108	55	20	1.5	0.51	0.75
----------------	----	----	-----	------	------

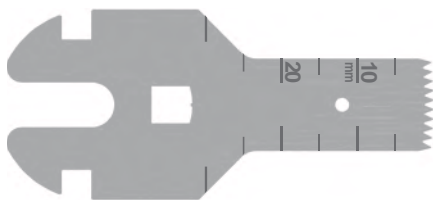

S87-109	30	12	1.3	0.51	0.80
----------------	----	----	-----	------	------

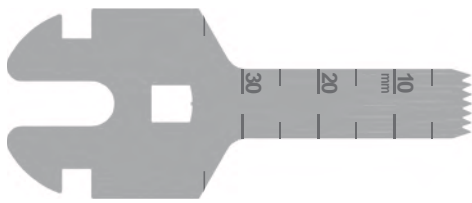

S87-110	35	9	1.3	0.60	0.80
----------------	----	---	-----	------	------

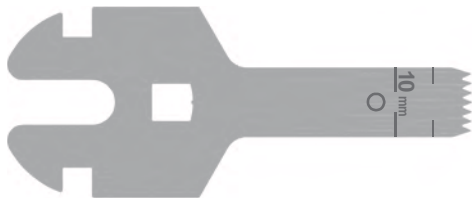

S87-111	10	9	1.3	0.60	0.80
----------------	----	---	-----	------	------

All blades shown actual size (1:1). All measurements in mm.



De Soutter[®] Sterile Packed Blades

S87

Part No.	Useable Length	Blade Width	Tooth Pitch	Blade Thickness	Cut Thickness
----------	----------------	-------------	-------------	-----------------	---------------

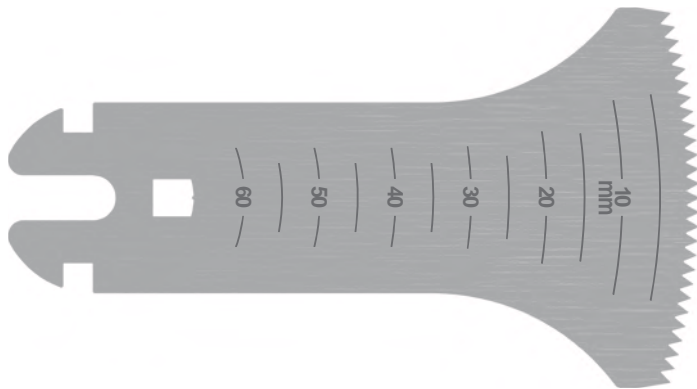

S87-112	65	50	1.9	0.60	0.80
----------------	----	----	-----	------	------

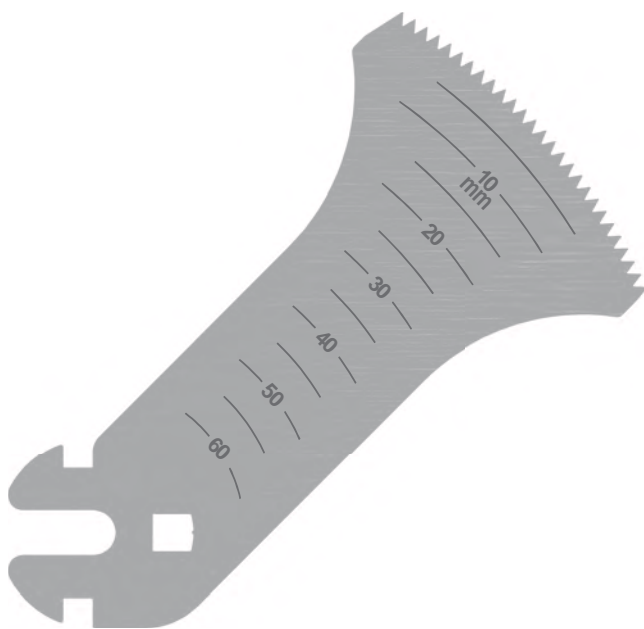

S87-113	65	50	1.9	0.60	0.80
----------------	----	----	-----	------	------

All blades shown actual size (1:1). All measurements in mm.

cm 1 2 3 4 5 6 7 8 9 10 11 12 13 14 15 16

De Soutter® Sterile Packed Blades

Part No.	Useable Length	Blade Width	Tooth Pitch	Blade Thickness	Cut Thickness
----------	----------------	-------------	-------------	-----------------	---------------

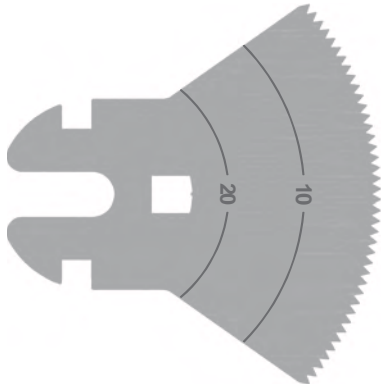

S87-118	23	50	1.4	0.51	0.90
----------------	----	----	-----	------	------

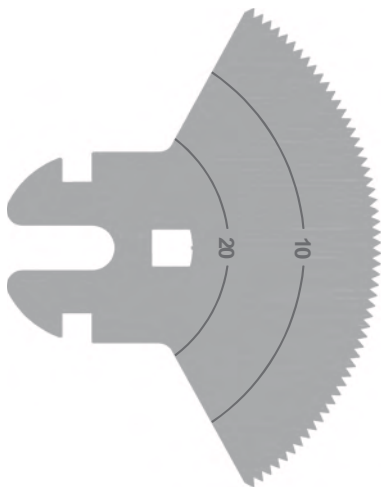

S87-119	23	63	1.4	0.51	0.90
----------------	----	----	-----	------	------

All blades shown actual size (1:1). All measurements in mm.



De Soutter® Sterile Packed Blades

Part No.	Useable Length	Blade Width	Tooth Pitch	Blade Thickness	Cut Thickness
----------	----------------	-------------	-------------	-----------------	---------------

S87

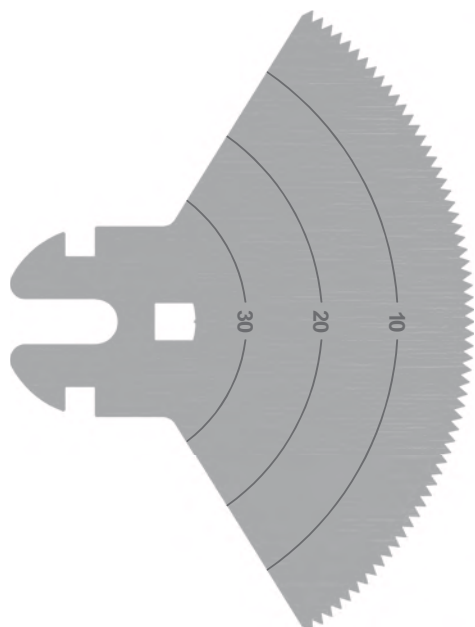

S87-120	35	82	1.6	0.51	1.00
----------------	----	----	-----	------	------

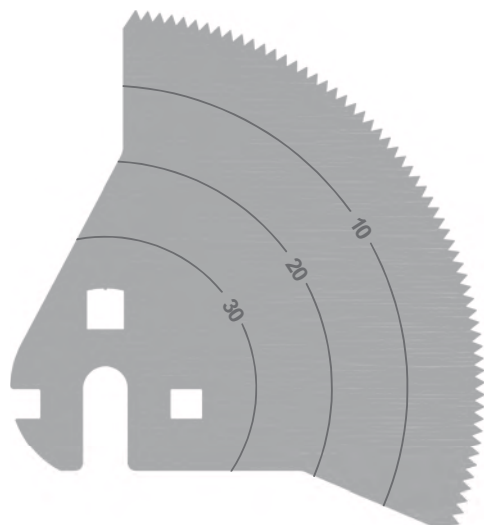

S87-121	35	82	1.6	0.51	1.00
----------------	----	----	-----	------	------

All blades shown actual size (1:1). All measurements in mm.



De Soutter® Sterile Packed Blades

Part No.	Useable Length	Blade Width	Tooth Pitch	Blade Thickness	Cut Thickness
----------	----------------	-------------	-------------	-----------------	---------------

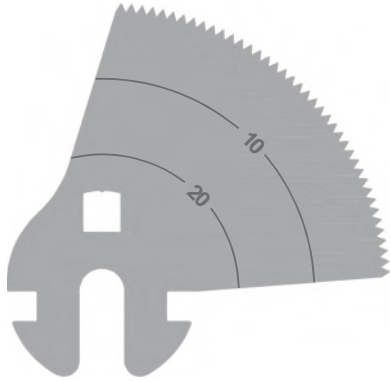

S87-123	23	50	1.4	0.51	0.90
----------------	----	----	-----	------	------

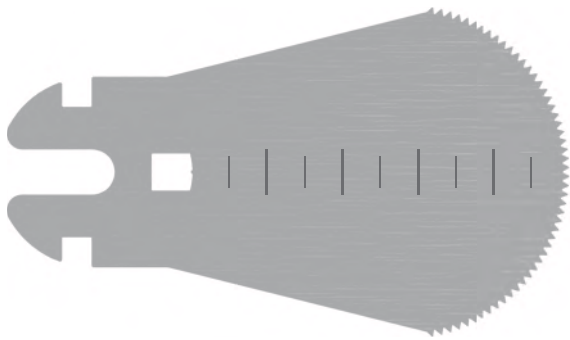

S87-125	48	43	1.2	0.60	0.80
----------------	----	----	-----	------	------



S87-130	9	13	2.1	1.27	1.50
----------------	---	----	-----	------	------

All blades shown actual size (1:1). All measurements in mm.



De Soutter® Sterile Packed Blades

S87

Part No.	Useable Length	Blade Width	Tooth Pitch	Blade Thickness	Cut Thickness
----------	----------------	-------------	-------------	-----------------	---------------

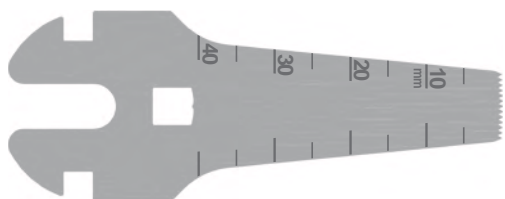

S87-134	41	9	0.7	0.38	0.60
----------------	----	---	-----	------	------

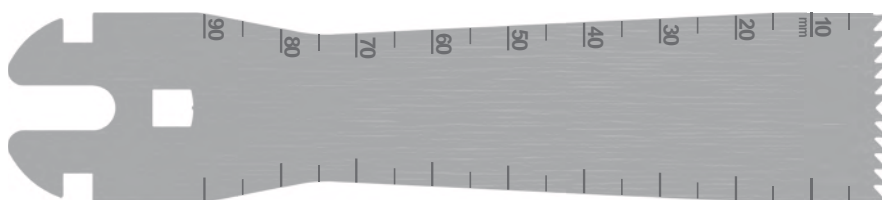

S87-200	90	25	2.1	0.80	0.97
----------------	----	----	-----	------	------

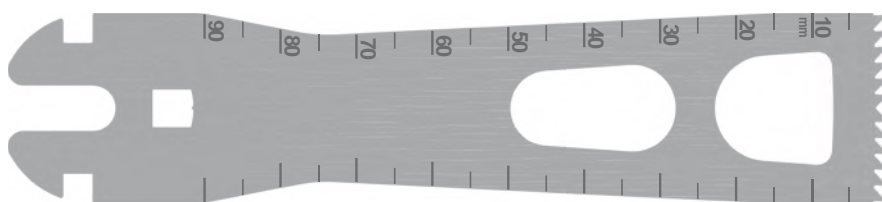

S87-206	90	25	2.1	1.20	1.27
----------------	----	----	-----	------	------



S87-207	90	25	2.1	1.20	1.27
----------------	----	----	-----	------	------



S87-208	90	25	2.1	1.47	1.47
----------------	----	----	-----	------	------

All blades shown actual size (1:1). All measurements in mm.

cm 1 2 3 4 5 6 7 8 9 10 11 12 13 14 15 16



De Soutter® Sterile Packed Blades

Part No.	Useable Length	Blade Width	Tooth Pitch	Blade Thickness	Cut Thickness
----------	----------------	-------------	-------------	-----------------	---------------

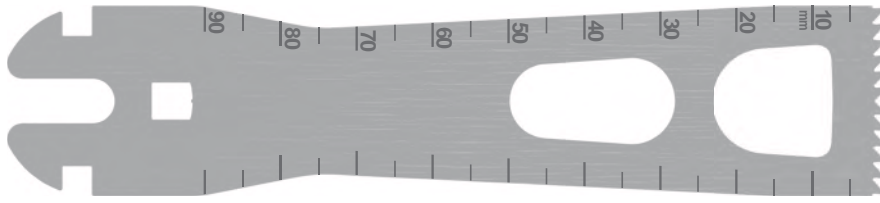

S87-209	90	25	2.1	1.47	1.47
----------------	----	----	-----	------	------

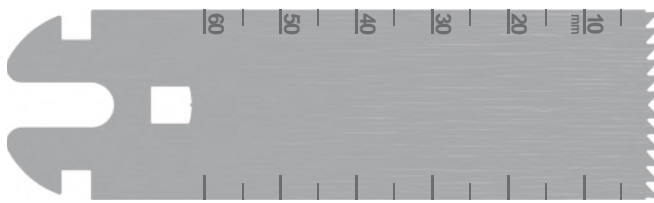

S87-219	60	25	2.1	0.80	0.90
----------------	----	----	-----	------	------

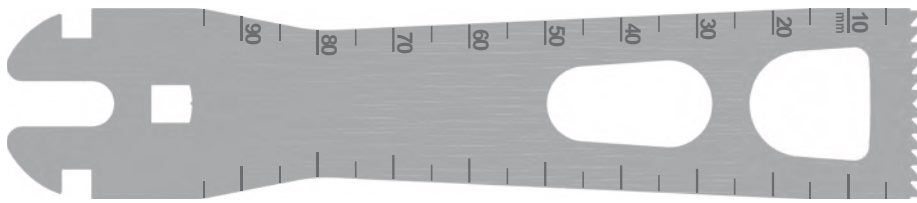

S87-228	95	25	2.1	0.80	0.90
----------------	----	----	-----	------	------

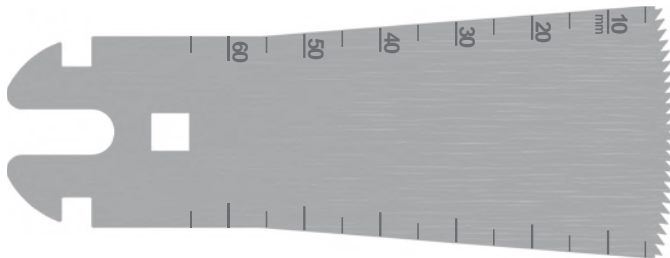

S87-256	65	33	1.4	0.80	0.95
----------------	----	----	-----	------	------

All blades shown actual size (1:1). All measurements in mm.



De Soutter® Sterile Packed Blades

S87

Part No.	Useable Length	Blade Width	Tooth Pitch	Blade Thickness	Cut Thickness
----------	----------------	-------------	-------------	-----------------	---------------

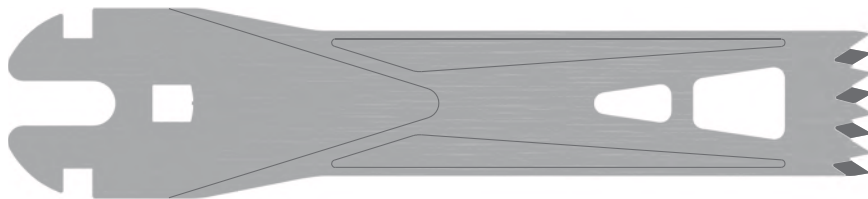

S87-323	90	19	2.6	1.27	1.27
----------------	----	----	-----	------	------

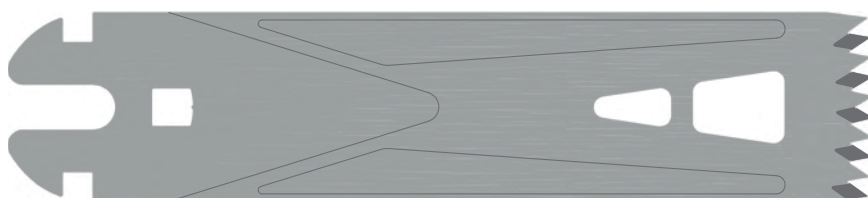

S87-325	90	25	2.6	1.00	1.00
----------------	----	----	-----	------	------

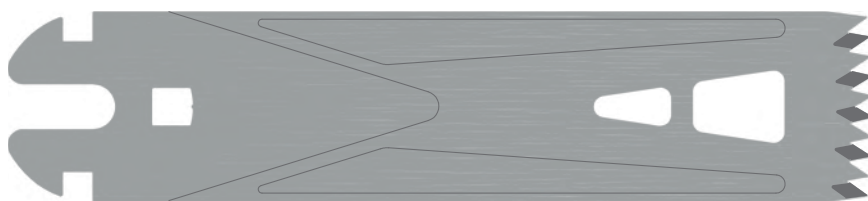

S87-326	90	25	2.6	1.27	1.27
----------------	----	----	-----	------	------

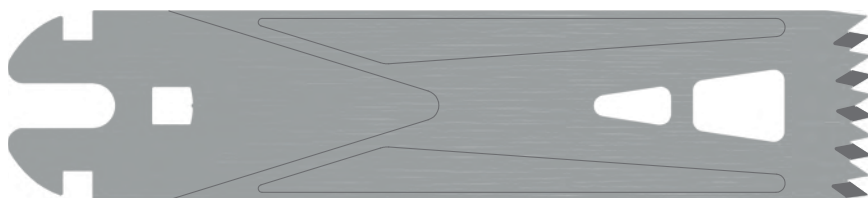

S87-327	90	25	2.6	1.37	1.37
----------------	----	----	-----	------	------

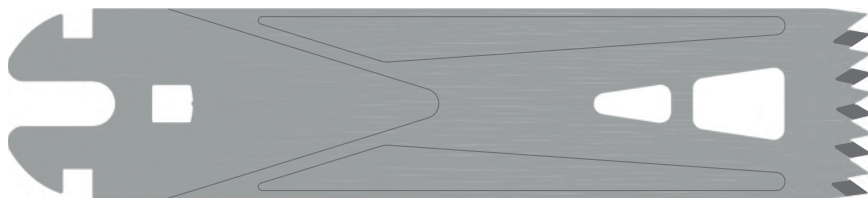

S87-328	90	25	2.6	1.47	1.47
----------------	----	----	-----	------	------

All blades shown actual size (1:1). All measurements in mm.

cm 1 2 3 4 5 6 7 8 9 10 11 12 13 14 15 16



De Soutter® Sterile Packed Blades

Part No.	Useable Length	Blade Width	Tooth Pitch	Blade Thickness	Cut Thickness
----------	----------------	-------------	-------------	-----------------	---------------

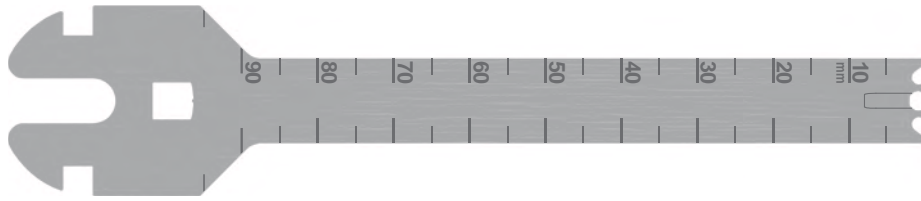

S87-411	95	11	3.4	1.20	1.27
----------------	----	----	-----	------	------

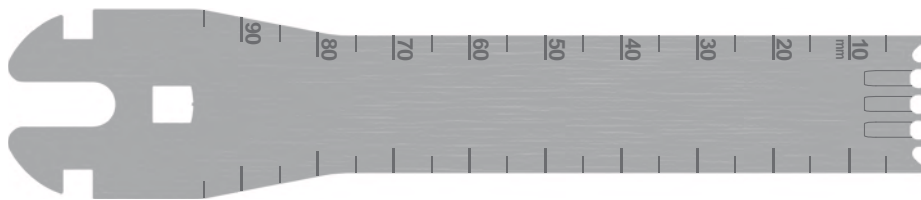

S87-413	95	18	3.4	1.20	1.27
----------------	----	----	-----	------	------

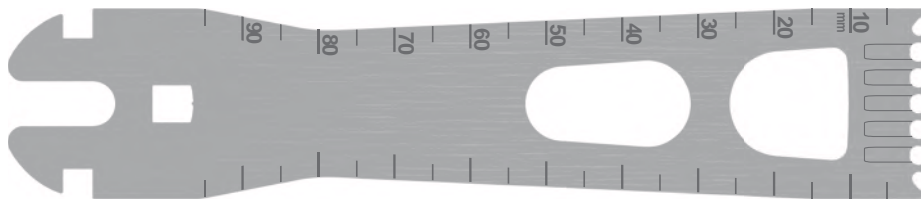

S87-416	95	25	3.4	1.20	1.27
----------------	----	----	-----	------	------

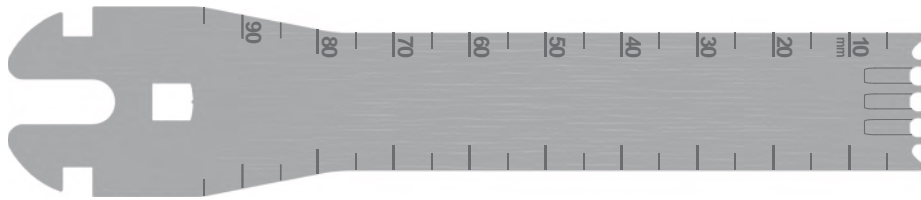

S87-423	95	18	3.4	1.27	1.27
----------------	----	----	-----	------	------

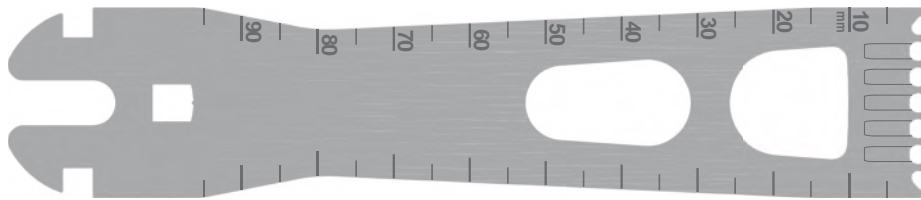

S87-426	95	25	3.4	1.27	1.27
----------------	----	----	-----	------	------

All blades shown actual size (1:1). All measurements in mm.



De Soutter® Sterile Packed Blades

S87

Part No.	Useable Length	Blade Width	Tooth Pitch	Blade Thickness	Cut Thickness
----------	----------------	-------------	-------------	-----------------	---------------

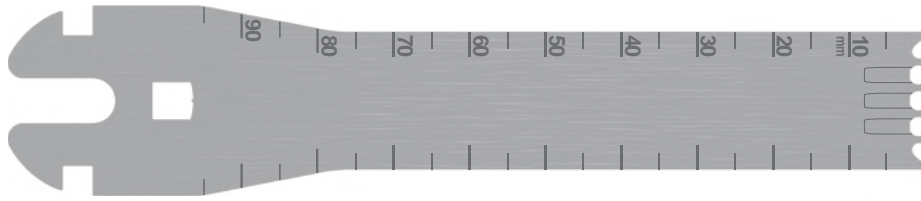

S87-433	95	18	3.4	1.00	1.00
----------------	----	----	-----	------	------

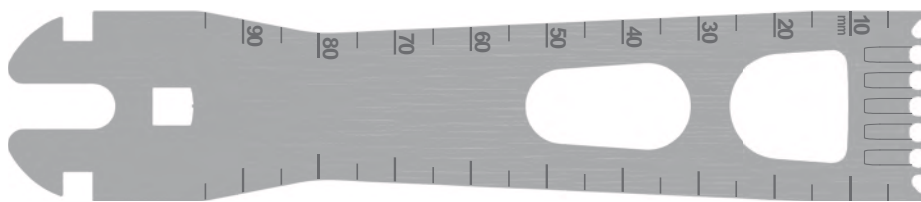

S87-436	95	25	3.4	1.00	1.00
----------------	----	----	-----	------	------

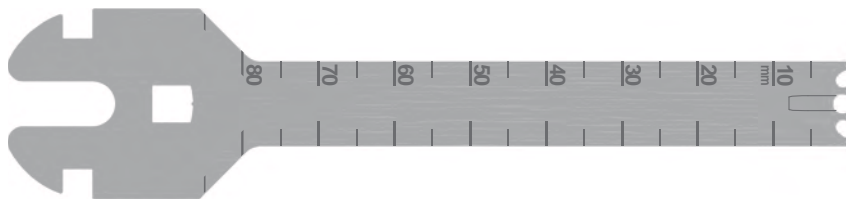

S87-451	85	11	3.4	0.90	1.00
----------------	----	----	-----	------	------



S87-469	75	11	3.4	1.47	1.47
----------------	----	----	-----	------	------



S87-500	70	10	2.1	1.20	1.27
----------------	----	----	-----	------	------

All blades shown actual size (1:1). All measurements in mm.

cm 1 2 3 4 5 6 7 8 9 10 11 12 13 14 15 16



De Soutter® Sterile Packed Blades

Part No.	Useable Length	Blade Width	Tooth Pitch	Blade Thickness	Cut Thickness
----------	----------------	-------------	-------------	-----------------	---------------

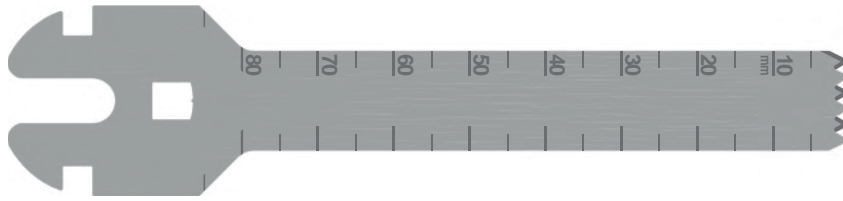

S87-501	85	13	2.1	1.20	1.27
----------------	----	----	-----	------	------

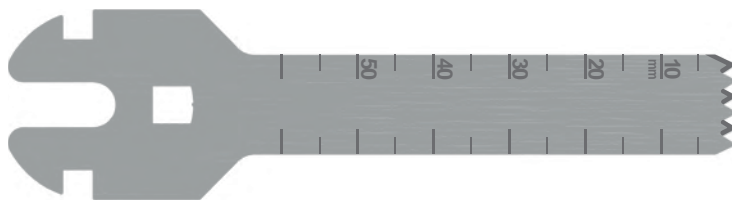

S87-502	70	13	2.1	1.27	1.27
----------------	----	----	-----	------	------

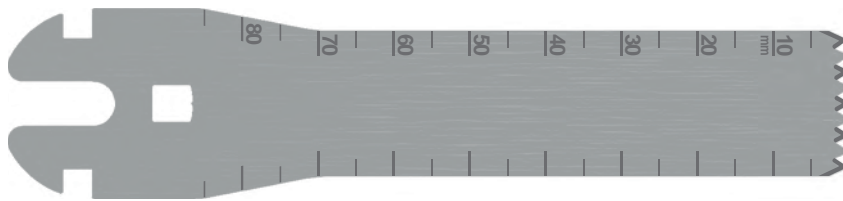

S87-503	85	19	2.1	1.20	1.27
----------------	----	----	-----	------	------

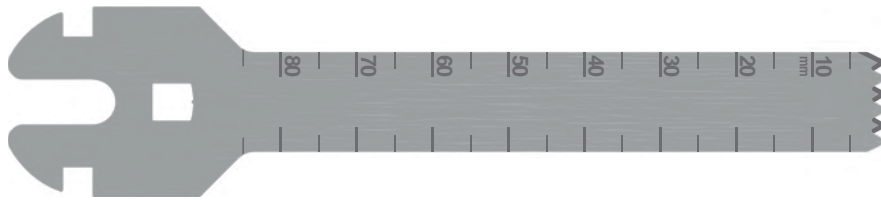

S87-505	90	13	2.1	1.30	1.37
----------------	----	----	-----	------	------

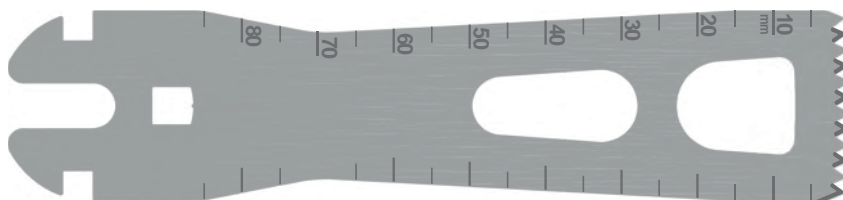

S87-506	85	25	2.1	1.20	1.27
----------------	----	----	-----	------	------

All blades shown actual size (1:1). All measurements in mm.



De Soutter® Sterile Packed Blades

Part No.	Useable Length	Blade Width	Tooth Pitch	Blade Thickness	Cut Thickness
----------	----------------	-------------	-------------	-----------------	---------------

S87

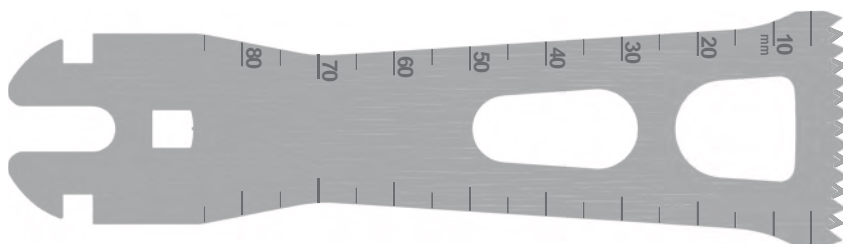

S87-508	85	31	2.1	1.20	1.27
----------------	----	----	-----	------	------

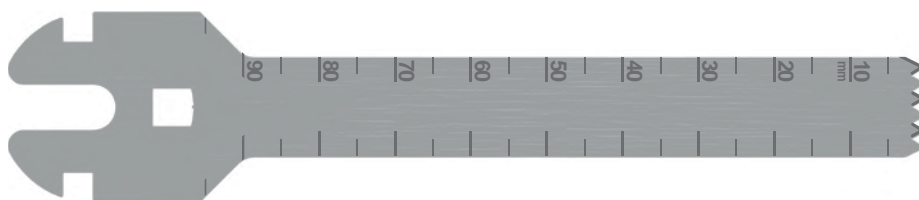

S87-510	95	13	2.1	0.89	0.89
----------------	----	----	-----	------	------

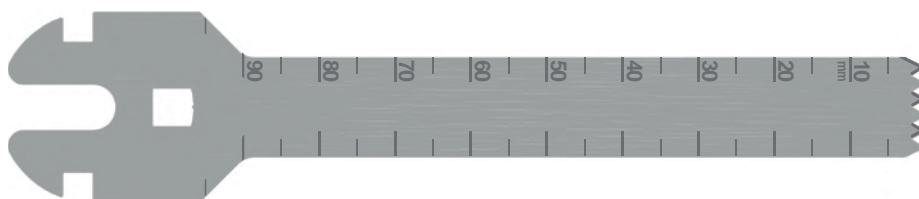

S87-511	95	13	2.1	1.20	1.27
----------------	----	----	-----	------	------

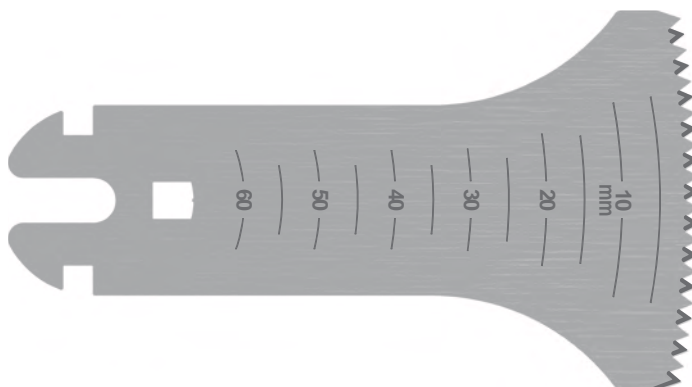

S87-512	65	50	2.1	0.60	0.60
----------------	----	----	-----	------	------

All blades shown actual size (1:1). All measurements in mm.

cm 1 2 3 4 5 6 7 8 9 10 11 12 13 14 15 16



De Soutter® Sterile Packed Blades

Part No.	Useable Length	Blade Width	Tooth Pitch	Blade Thickness	Cut Thickness
----------	----------------	-------------	-------------	-----------------	---------------

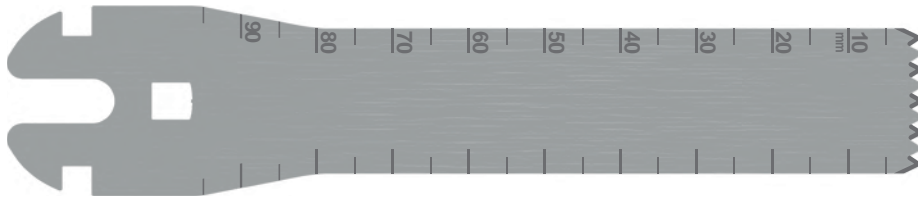

S87-513	95	19	2.1	1.20	1.27
----------------	----	----	-----	------	------

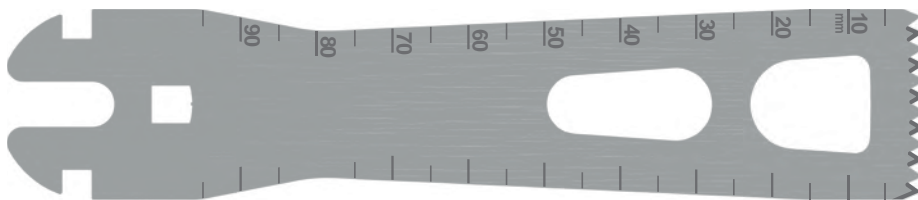

S87-515	95.0	25.0	2.1	1.19	1.19
----------------	------	------	-----	------	------

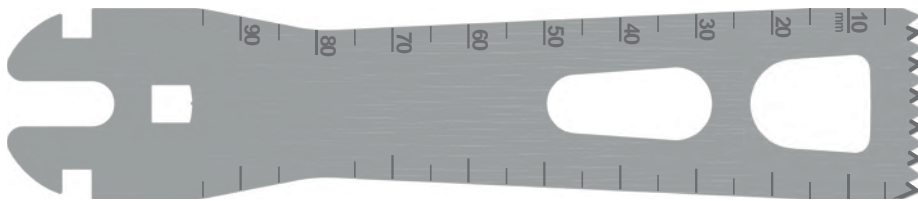

S87-516	95	25	2.1	1.20	1.27
----------------	----	----	-----	------	------

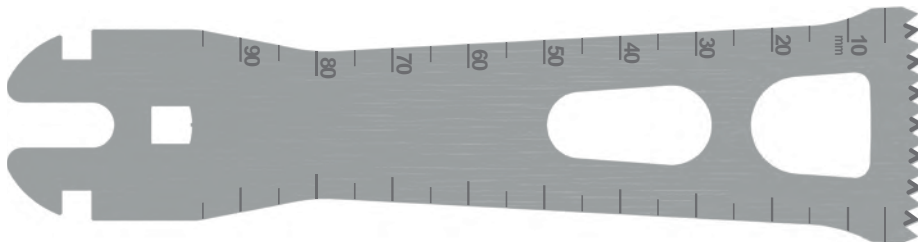

S87-518	95	31	2.1	1.20	1.27
----------------	----	----	-----	------	------

All blades shown actual size (1:1). All measurements in mm.



De Soutter® Sterile Packed Blades

S87

Part No.	Useable Length	Blade Width	Tooth Pitch	Blade Thickness	Cut Thickness
----------	----------------	-------------	-------------	-----------------	---------------

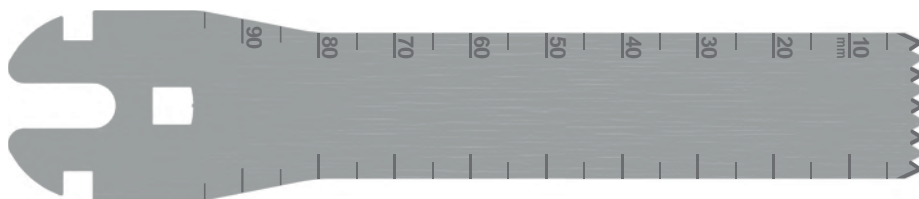

S87-521	95.0	19.0	2.1	1.07	1.07
----------------	------	------	-----	------	------

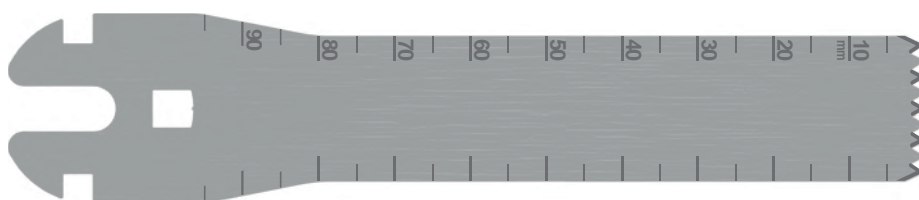

S87-522	95.0	19.0	2.1	1.19	1.19
----------------	------	------	-----	------	------

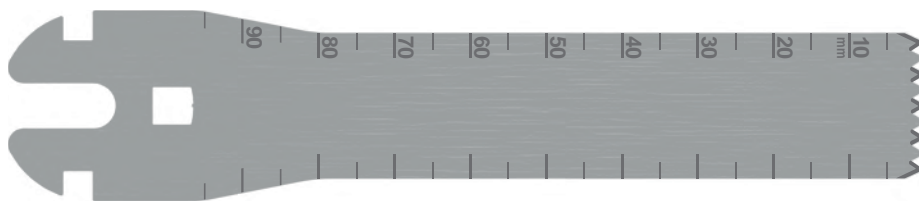

S87-523	95	19	2.1	1.27	1.27
----------------	----	----	-----	------	------

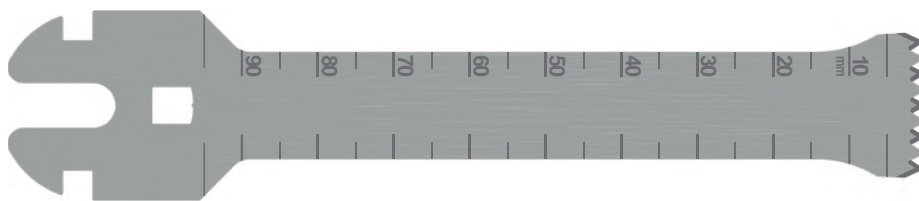

S87-525	95	19	2.1	1.27	1.27
----------------	----	----	-----	------	------

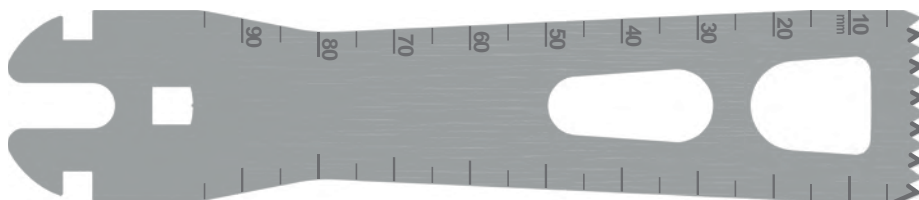

S87-526	95	25	2.1	1.27	1.27
----------------	----	----	-----	------	------

All blades shown actual size (1:1). All measurements in mm.

cm 1 2 3 4 5 6 7 8 9 10 11 12 13 14 15 16



De Soutter® Sterile Packed Blades

Part No.	Useable Length	Blade Width	Tooth Pitch	Blade Thickness	Cut Thickness
----------	----------------	-------------	-------------	-----------------	---------------

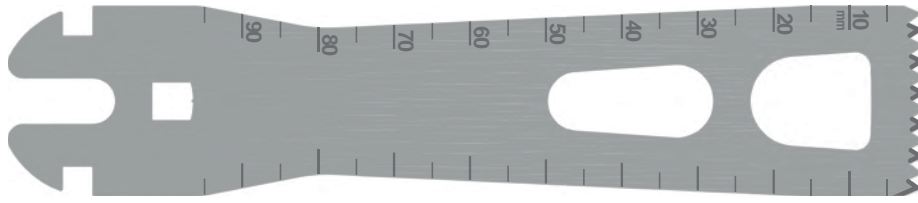

S87-527	95	25	2.1	1.30	1.37
----------------	----	----	-----	------	------

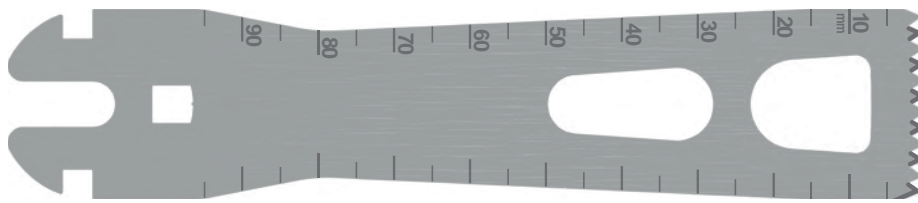

S87-528	95	25	2.1	1.47	1.47
----------------	----	----	-----	------	------

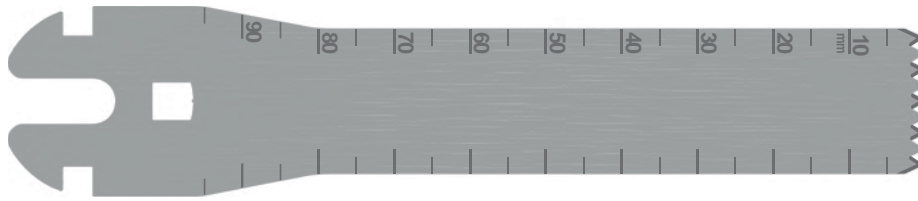

S87-533	95	19	2.1	1.00	1.00
----------------	----	----	-----	------	------

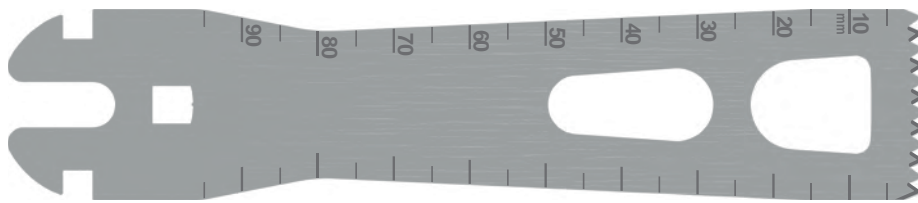

S87-536	95	25	2.1	1.00	1.00
----------------	----	----	-----	------	------

All blades shown actual size (1:1). All measurements in mm.



De Soutter® Sterile Packed Blades

S87

Part No.	Useable Length	Blade Width	Tooth Pitch	Blade Thickness	Cut Thickness
----------	----------------	-------------	-------------	-----------------	---------------

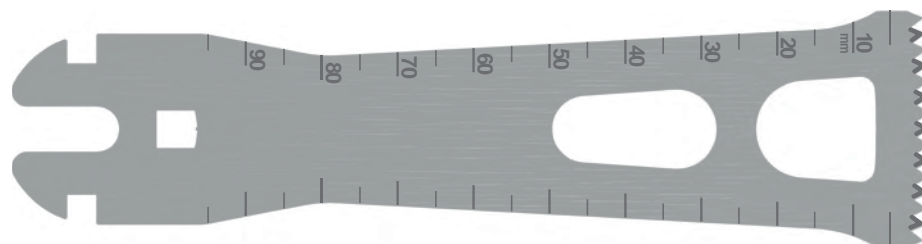

S87-538	95	31	2.1	1.30	1.37
----------------	----	----	-----	------	------

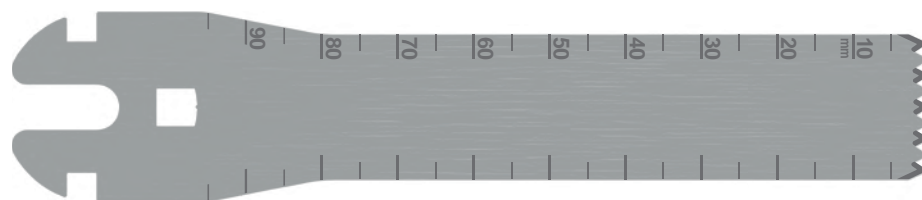

S87-543	95	19	2.1	1.47	1.47
----------------	----	----	-----	------	------



S87-545	75	13	2.1	1.27	1.27
----------------	----	----	-----	------	------



S87-547	75	13	2.1	1.37	1.47
----------------	----	----	-----	------	------

All blades shown actual size (1:1). All measurements in mm.

cm 1 2 3 4 5 6 7 8 9 10 11 12 13 14 15 16



De Soutter® Sterile Packed Blades

Part No.	Useable Length	Blade Width	Tooth Pitch	Blade Thickness	Cut Thickness
----------	----------------	-------------	-------------	-----------------	---------------

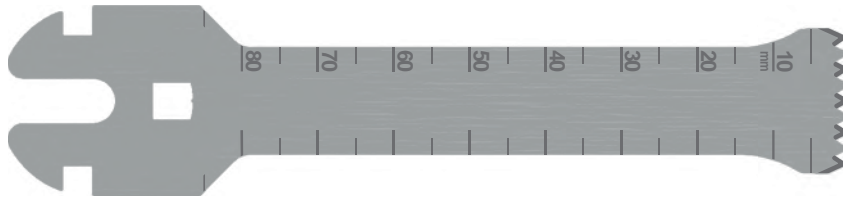

S87-548	85	19	2.1	1.30	1.37
----------------	----	----	-----	------	------

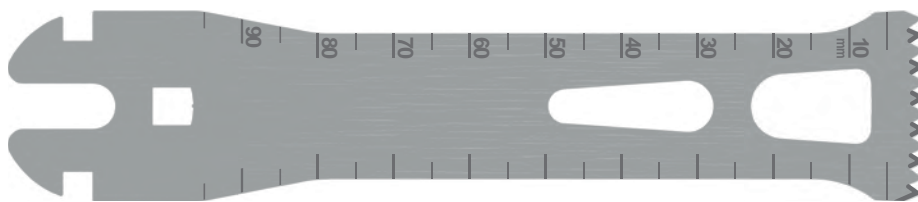

S87-549	95	25	2.1	1.27	1.27
----------------	----	----	-----	------	------

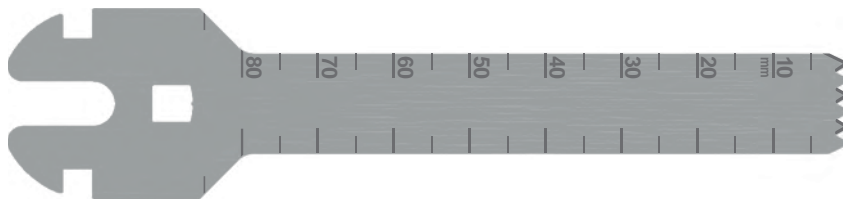

S87-551	85	13	2.1	0.90	0.97
----------------	----	----	-----	------	------

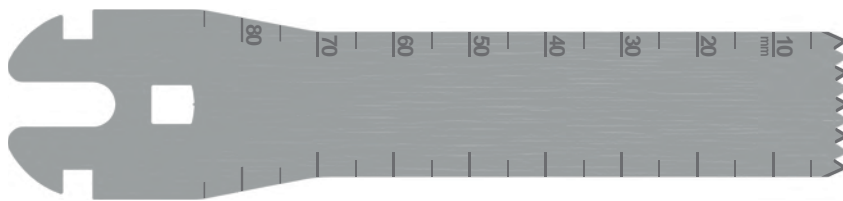

S87-553	85	19	2.1	0.90	0.97
----------------	----	----	-----	------	------

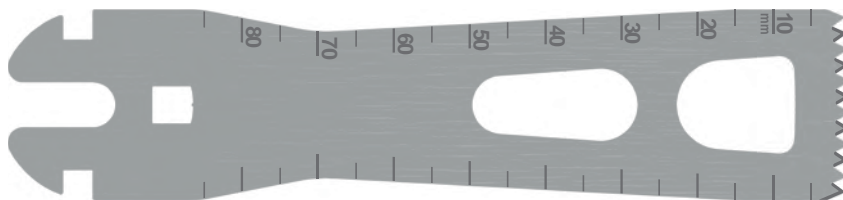

S87-556	85	25	2.1	0.90	0.97
----------------	----	----	-----	------	------

All blades shown actual size (1:1). All measurements in mm.



De Soutter® Sterile Packed Blades

Part No.	Useable Length	Blade Width	Tooth Pitch	Blade Thickness	Cut Thickness
----------	----------------	-------------	-------------	-----------------	---------------

S87

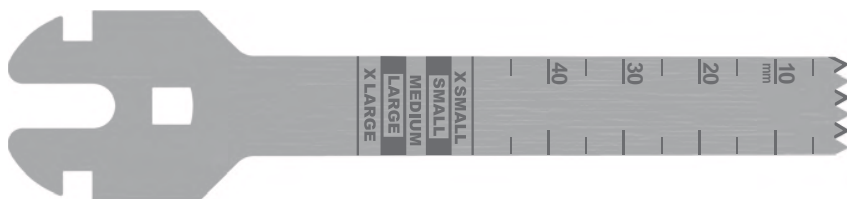

S87-561	85	13	2.1	0.89	0.89
----------------	----	----	-----	------	------

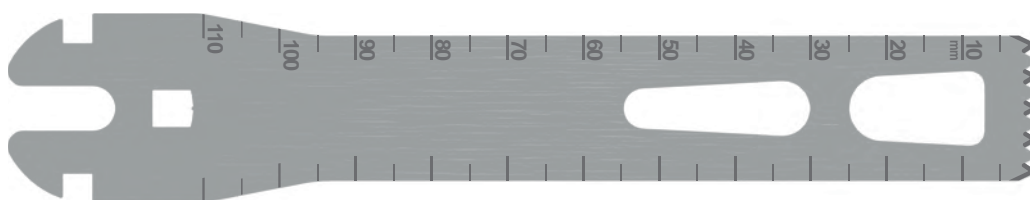

S87-563	110	19	2.1	1.27	1.37
----------------	-----	----	-----	------	------

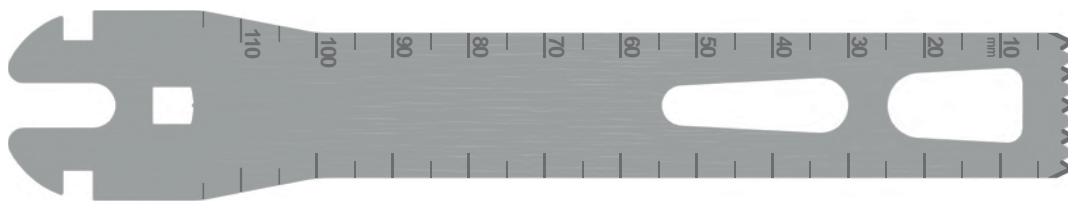

S87-585	115	19	2.1	1.20	1.27
----------------	-----	----	-----	------	------

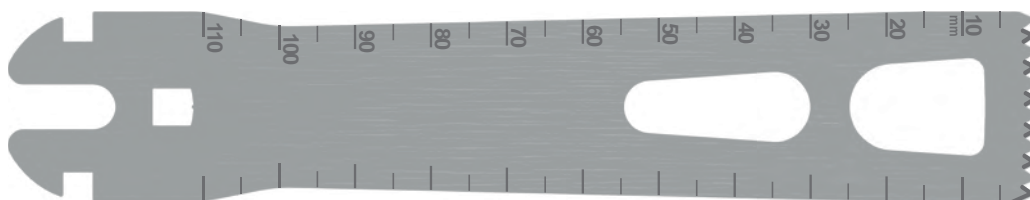

S87-595	110	25	2.1	1.20	1.27
----------------	-----	----	-----	------	------

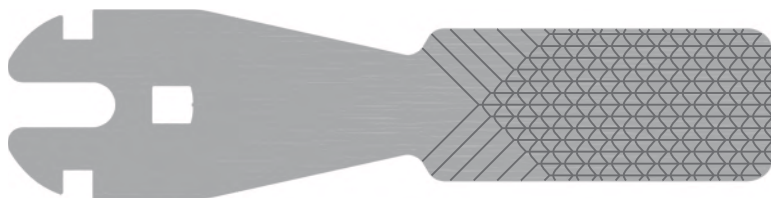

S87-600	75	20	2.2	0.70	1.25
----------------	----	----	-----	------	------

All blades shown actual size (1:1). All measurements in mm.

cm 1 2 3 4 5 6 7 8 9 10 11 12 13 14 15 16



De Soutter® Sterile Packed Blades

Part No.	Useable Length	Blade Width	Tooth Pitch	Blade Thickness	Cut Thickness
----------	----------------	-------------	-------------	-----------------	---------------

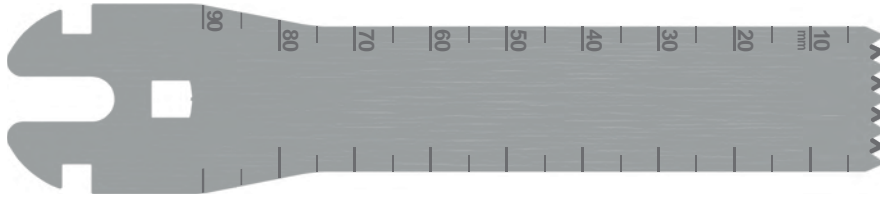

S87-5657	90	19	2.1	1.30	1.37
-----------------	----	----	-----	------	------

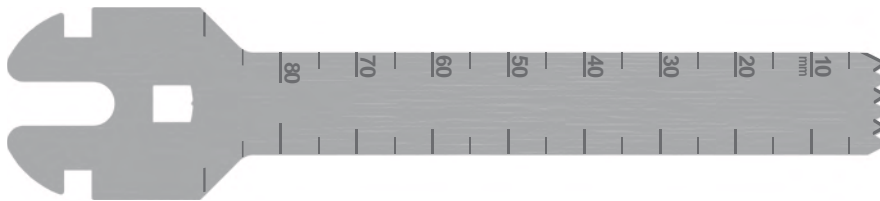



S87-6638	90	13	2.1	1.47	1.47
-----------------	----	----	-----	------	------

All blades shown actual size (1:1). All measurements in mm.

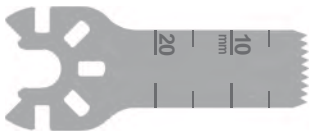
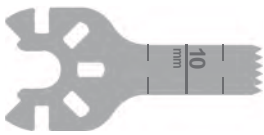
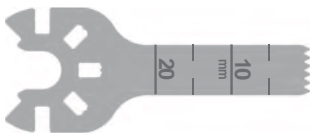

De Soutter® Sterile Packed Blades

S88

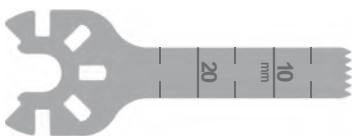
Part No.	Useable Length	Blade Width	Tooth Pitch	Blade Thickness	Cut Thickness
 S88-100	25	10	1.1	0.38	0.60
 S88-101	22	10	1.1	0.38	0.60
 S88-102	16	6.4	1.1	0.38	0.60
 S88-103	22	6.4	1.1	0.38	0.60
 S88-104	16	10	1.1	0.38	0.60
 S88-105	27	6.4	1.1	0.38	0.60

All blades shown actual size (1:1). All measurements in mm.



De Soutter® Sterile Packed Blades

Part No.	Useable Length	Blade Width	Tooth Pitch	Blade Thickness	Cut Thickness
----------	----------------	-------------	-------------	-----------------	---------------

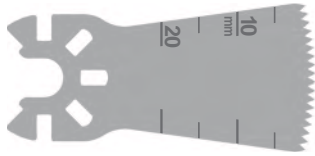

S88-106	22	19	1.1	0.38	0.60
----------------	----	----	-----	------	------



S88-107	46	19	1.1	0.38	0.60
----------------	----	----	-----	------	------

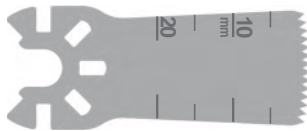

S88-108	22	15	1.1	0.38	0.60
----------------	----	----	-----	------	------



S88-109	46	15	1.1	0.38	0.60
----------------	----	----	-----	------	------



S88-110	35	10	1.3	0.38	0.60
----------------	----	----	-----	------	------



S88-111	10	10	1.1	0.38	0.60
----------------	----	----	-----	------	------

All blades shown actual size (1:1). All measurements in mm.



De Soutter® Sterile Packed Blades

S88

Part No.	Useable Length	Blade Width	Tooth Pitch	Blade Thickness	Cut Thickness
----------	----------------	-------------	-------------	-----------------	---------------



S88-113	20	10	1.3	0.38	0.60
----------------	----	----	-----	------	------



S88-114	28	3	1.1	0.38	0.60
----------------	----	---	-----	------	------



S88-115	20	3	1.1	0.38	0.60
----------------	----	---	-----	------	------

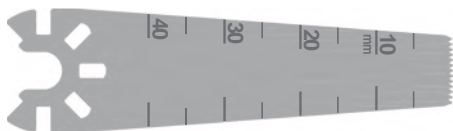

S88-134	41	9	0.7	0.38	0.60
----------------	----	---	-----	------	------

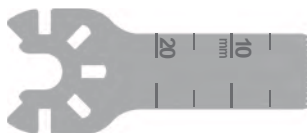

S88-138	22	9.5	0.7	0.38	0.66
----------------	----	-----	-----	------	------

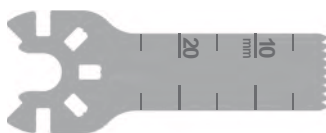

S88-150	25	10	1.1	0.70	1.00
----------------	----	----	-----	------	------

All blades shown actual size (1:1). All measurements in mm.

cm 1 2 3 4 5 6 7 8 9 10 11 12 13 14 15 16



De Soutter® Sterile Packed Blades

Part No.	Useable Length	Blade Width	Tooth Pitch	Blade Thickness	Cut Thickness
----------	----------------	-------------	-------------	-----------------	---------------

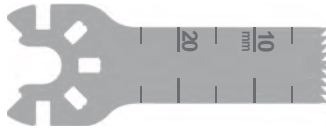

S88-151	25	10	1.1	0.70	0.80
----------------	----	----	-----	------	------



S88-152	16	6.4	1.3	0.70	1.00
----------------	----	-----	-----	------	------

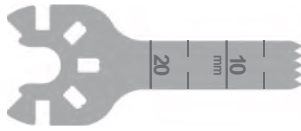

S88-153	22	6.4	1.3	0.70	1.00
----------------	----	-----	-----	------	------

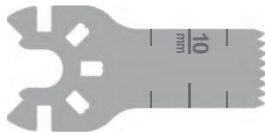

S88-154	16	10	1.3	0.70	1.00
----------------	----	----	-----	------	------

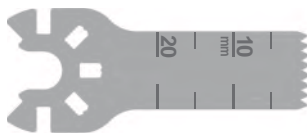

S88-156	22	10	1.3	0.70	1.00
----------------	----	----	-----	------	------



S88-157	46	19	1.3	0.70	1.00
----------------	----	----	-----	------	------

All blades shown actual size (1:1). All measurements in mm.



De Soutter® Sterile Packed Blades

Part No.	Useable Length	Blade Width	Tooth Pitch	Blade Thickness	Cut Thickness
----------	----------------	-------------	-------------	-----------------	---------------

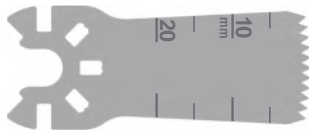

S88-158	22	15	1.3	0.70	1.00
----------------	----	----	-----	------	------



S88-159	46	15	1.3	0.70	1.00
----------------	----	----	-----	------	------



S88-160	35	10	1.3	0.70	1.00
----------------	----	----	-----	------	------

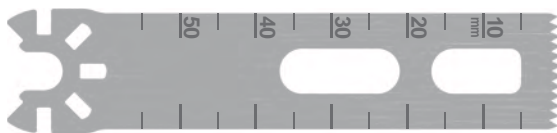

S88-162	55	15	1.3	0.70	1.00
----------------	----	----	-----	------	------



S88-180	15.5	14	1.0	0.70	1.00
----------------	------	----	-----	------	------



S88-181	15.5	14	1.0	0.70	1.00
----------------	------	----	-----	------	------

All blades shown actual size (1:1). All measurements in mm.

cm 1 2 3 4 5 6 7 8 9 10 11 12 13 14 15 16



De Soutter® Sterile Packed Blades

Part No.	Useable Length	Blade Width	Tooth Pitch	Blade Thickness	Cut Thickness
----------	----------------	-------------	-------------	-----------------	---------------

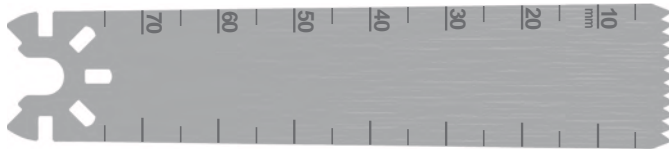

S88-470	70	19	1.7	0.80	1.00
----------------	----	----	-----	------	------

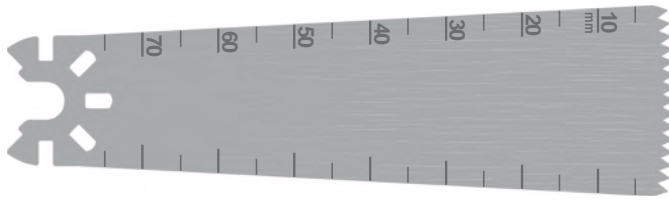

S88-475	70	25	1.7	0.60	0.80
----------------	----	----	-----	------	------

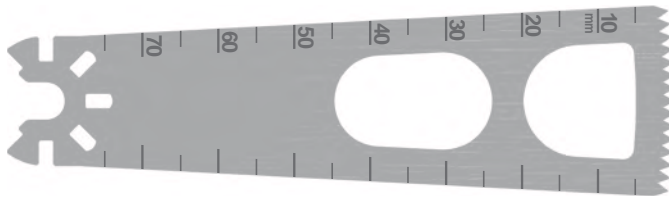

S88-476	70	25	1.7	0.80	1.00
----------------	----	----	-----	------	------

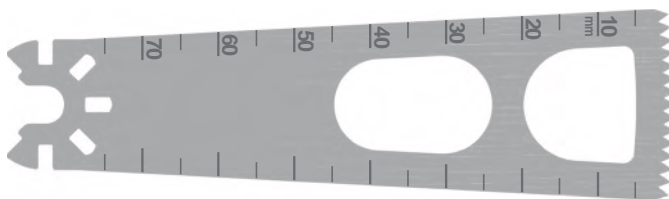

S88-477	70	25	1.7	1.00	1.20
----------------	----	----	-----	------	------

All blades shown actual size (1:1). All measurements in mm.



De Soutter® Sterile Packed Blades

S88

Part No.	Useable Length	Blade Width	Tooth Pitch	Blade Thickness	Cut Thickness
----------	----------------	-------------	-------------	-----------------	---------------

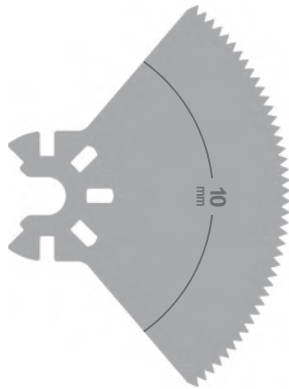

S88-908	19	50	1.4	0.38	0.60
----------------	----	----	-----	------	------

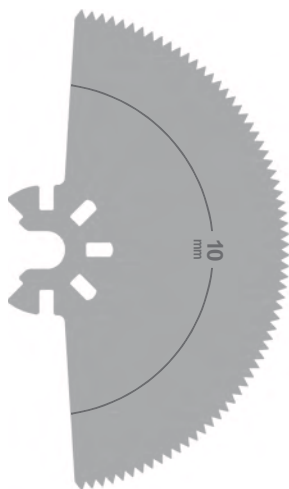

S88-909	19	63	1.4	0.38	0.60
----------------	----	----	-----	------	------

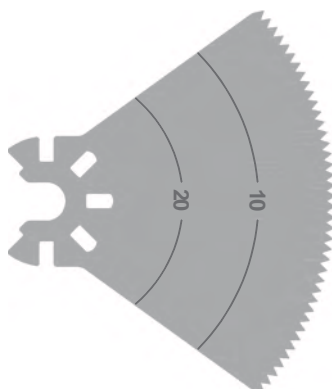

S88-918	25	50	1.4	0.38	0.60
----------------	----	----	-----	------	------

All blades shown actual size (1:1). All measurements in mm.



De Soutter® Sterile Packed Blades

Part No.	Useable Length	Blade Width	Tooth Pitch	Blade Thickness	Cut Thickness
----------	----------------	-------------	-------------	-----------------	---------------

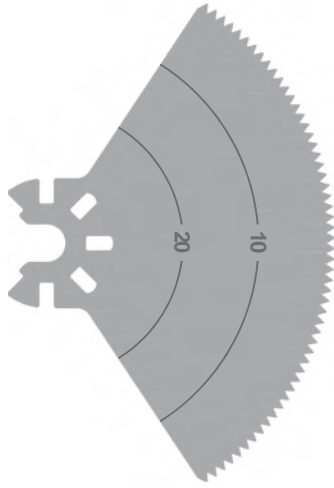

S88-919	25	63	1.4	0.38	0.60
----------------	----	----	-----	------	------

All blades shown actual size (1:1). All measurements in mm.

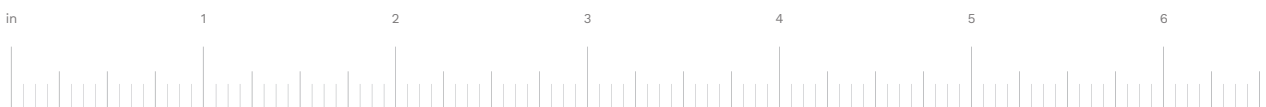

De Soutter® Sterile Packed Blades

S89

Part No.	Useable Length	Blade Width	Tooth Pitch	Blade Thickness	Cut Thickness
----------	----------------	-------------	-------------	-----------------	---------------



S89-1111	25	9	1.3	0.60	0.80
-----------------	----	---	-----	------	------

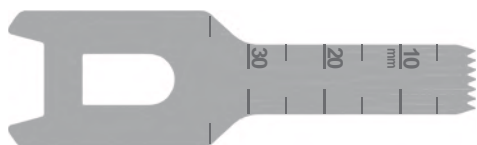

S89-1211	35	9	1.3	0.60	0.80
-----------------	----	---	-----	------	------

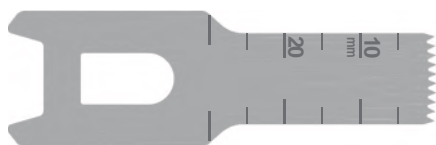

S89-1221	30	12	1.3	0.51	0.70
-----------------	----	----	-----	------	------



S89-1351	55	19	1.5	0.51	0.70
-----------------	----	----	-----	------	------



S89-1421	60	12	1.7	0.60	0.80
-----------------	----	----	-----	------	------

All blades shown actual size (1:1). All measurements in mm.

cm 1 2 3 4 5 6 7 8 9 10 11 12 13 14 15 16



De Soutter® Sterile Packed Blades

Part No.	Useable Length	Blade Width	Tooth Pitch	Blade Thickness	Cut Thickness
----------	----------------	-------------	-------------	-----------------	---------------



S89-1440	60	14	1.4	0.38	0.60
-----------------	----	----	-----	------	------

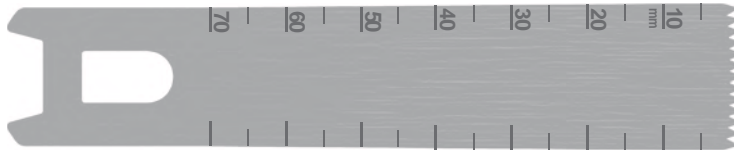

S89-1452	70	19	1.5	0.70	0.90
-----------------	----	----	-----	------	------

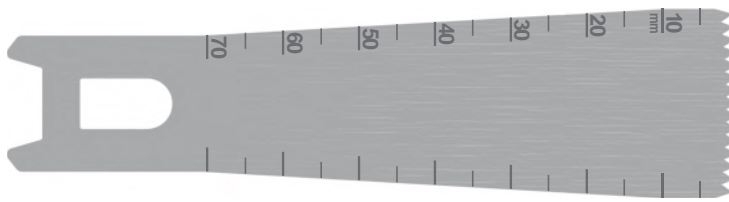

S89-1473	70	25	1.7	0.80	1.00
-----------------	----	----	-----	------	------

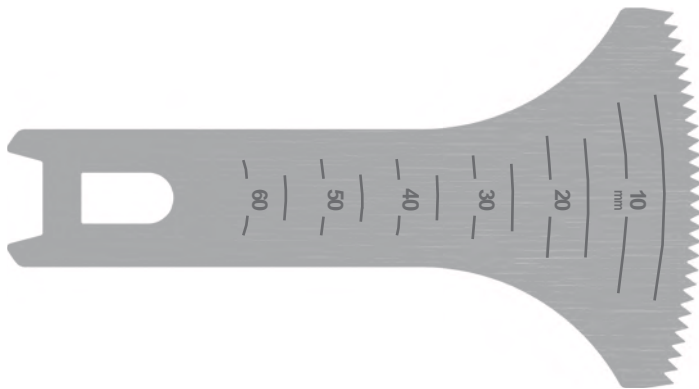

S89-1491	65	50	1.9	0.60	0.80
-----------------	----	----	-----	------	------

All blades shown actual size (1:1). All measurements in mm.



De Soutter® Sterile Packed Blades

S89

Part No.	Useable Length	Blade Width	Tooth Pitch	Blade Thickness	Cut Thickness
----------	----------------	-------------	-------------	-----------------	---------------

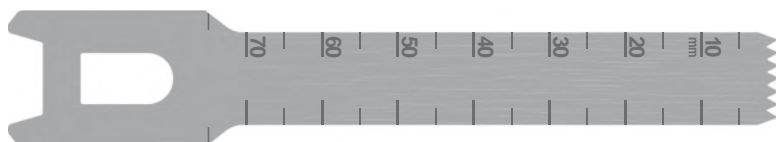

S89-1522	75	12	1.7	0.70	0.90
-----------------	----	----	-----	------	------



S89-1553	85	19	1.7	0.80	1.00
-----------------	----	----	-----	------	------

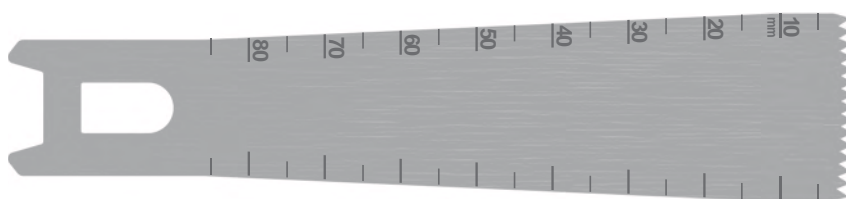

S89-1573	85	25	1.7	0.80	1.00
-----------------	----	----	-----	------	------

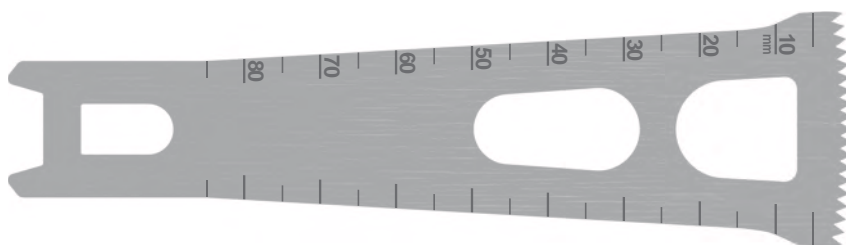

S89-1586	85	31	1.7	1.20	1.27
-----------------	----	----	-----	------	------

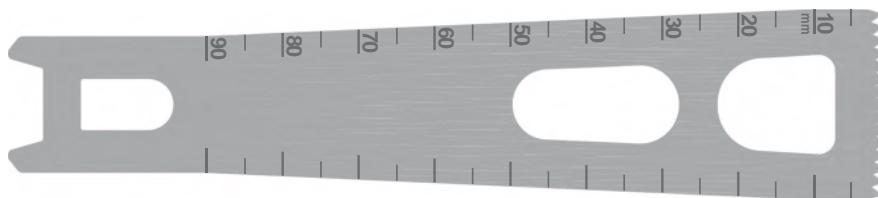

S89-1676	90	25	1.7	1.20	1.27
-----------------	----	----	-----	------	------

All blades shown actual size (1:1). All measurements in mm.

cm 1 2 3 4 5 6 7 8 9 10 11 12 13 14 15 16



De Soutter® Sterile Packed Blades

Part No.	Useable Length	Blade Width	Tooth Pitch	Blade Thickness	Cut Thickness
----------	----------------	-------------	-------------	-----------------	---------------

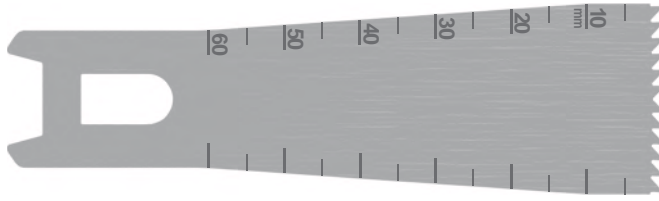

S89-2472	60	25	2.1	0.80	0.90
-----------------	----	----	-----	------	------

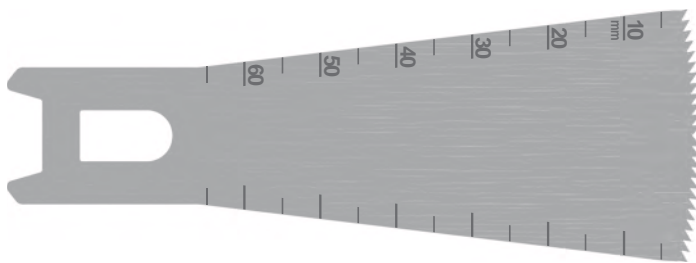

S89-2483	65	33	1.4	0.90	0.97
-----------------	----	----	-----	------	------

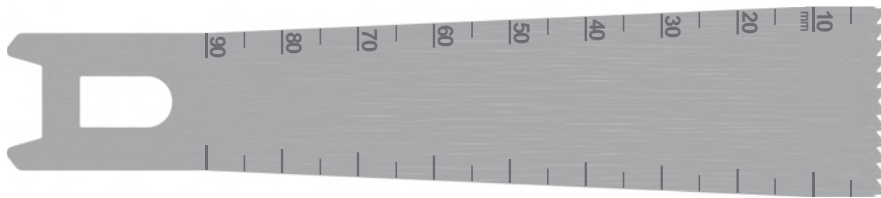

S89-2673	90	25	2.1	0.90	0.97
-----------------	----	----	-----	------	------

S89-2676	90	25	2.1	1.20	1.27
-----------------	----	----	-----	------	------

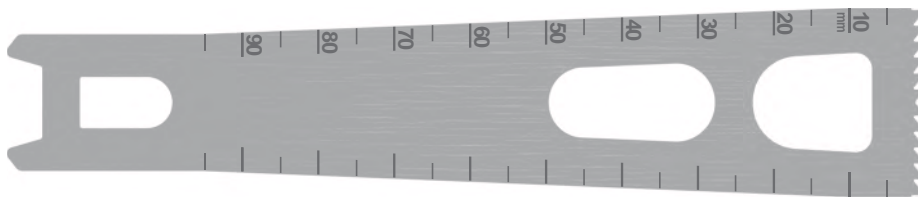

S89-2772	95	25	2.1	0.80	0.90
-----------------	----	----	-----	------	------

All blades shown actual size (1:1). All measurements in mm.



De Soutter® Sterile Packed Blades

S89

Part No.	Useable Length	Blade Width	Tooth Pitch	Blade Thickness	Cut Thickness
----------	----------------	-------------	-------------	-----------------	---------------

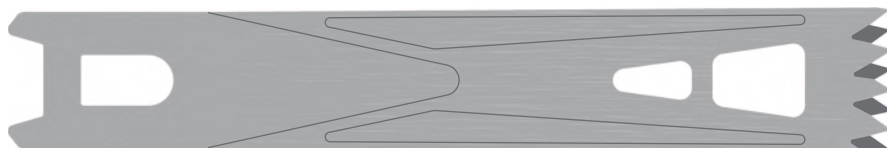

S89-3656	90	19	2.6	1.27	1.27
-----------------	----	----	-----	------	------

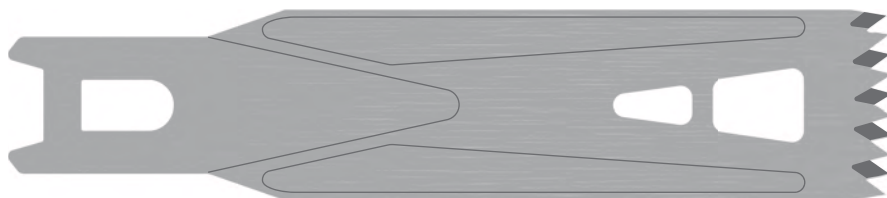

S89-3673	90	25	2.6	1.00	1.00
S89-3675	90	25	2.6	1.19	1.19
S89-3676	90	25	2.6	1.27	1.27
S89-3677	90	25	2.6	1.37	1.37
S89-3678	90	25	2.6	1.47	1.47

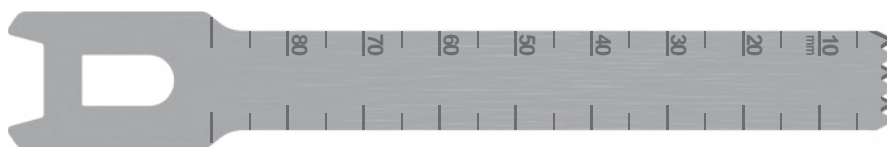

S89-5632	90	13	2.1	0.80	0.89
S89-5633	90	13	2.1	0.90	0.97
S89-5636	90	13	2.1	1.20	1.27
S89-5637	90	13	2.1	1.30	1.37



S89-5652	90	19	2.1	0.80	0.89
S89-5653	90	19	2.1	0.90	0.97
S89-5655	90	19	2.1	1.07	1.19
S89-5656	90	19	2.1	1.20	1.27
S89-5657	90	19	2.1	1.30	1.37
S89-5658	90	19	2.1	1.35	1.47

All blades shown actual size (1:1). All measurements in mm.

cm 1 2 3 4 5 6 7 8 9 10 11 12 13 14 15 16



De Soutter® Sterile Packed Blades

Part No.	Useable Length	Blade Width	Tooth Pitch	Blade Thickness	Cut Thickness
----------	----------------	-------------	-------------	-----------------	---------------

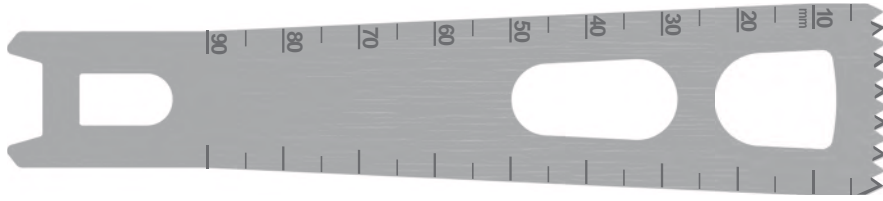

S89-5672	90	25	2.1	0.80	0.89
S89-5673	90	25	2.1	0.90	0.97
S89-5674	90	25	2.1	0.99	1.07
S89-5675	90	25	2.1	1.07	1.19
S89-5676	90	25	2.1	1.20	1.27
S89-5677	90	25	2.1	1.30	1.37
S89-5678	90	25	2.1	1.35	1.47

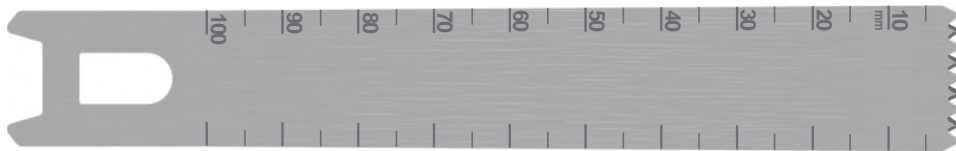

S89-5755	100	19	2.1	1.07	1.19
S89-5756	100	19	2.1	1.20	1.27
S89-5757	100	19	2.1	1.30	1.37



S89-6506	80	8	2.1	1.27	1.27
-----------------	----	---	-----	------	------

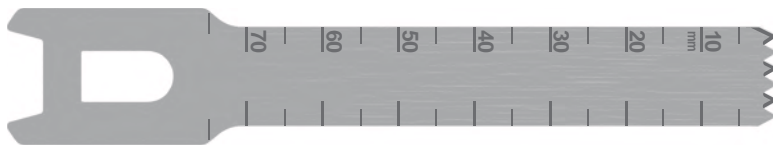

S89-6536	75	13	2.1	1.27	1.27
-----------------	----	----	-----	------	------

All blades shown actual size (1:1). All measurements in mm.



De Soutter® Sterile Packed Blades

S89

Part No.	Useable Length	Blade Width	Tooth Pitch	Blade Thickness	Cut Thickness
----------	----------------	-------------	-------------	-----------------	---------------



S89-6556	75	19	2.1	1.27	1.27
S89-6557	75	19	2.1	1.37	1.37

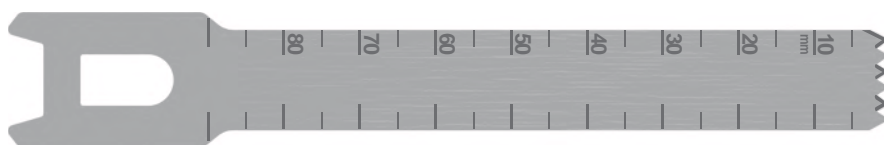

S89-6632	90	13	2.1	0.89	0.89
S89-6633	90	13	2.1	0.97	0.97
S89-6635	90	13	2.1	1.19	1.19
S89-6636	90	13	2.1	1.27	1.27
S89-6637	90	13	2.1	1.37	1.37
S89-6638	90	13	2.1	1.47	1.47



S89-6653	90	19	2.1	0.97	0.97
S89-6655	90	19	2.1	1.19	1.19
S89-6656	90	19	2.1	1.27	1.27
S89-6657	90	19	2.1	1.37	1.37
S89-6658	90	19	2.1	1.47	1.47

All blades shown actual size (1:1). All measurements in mm.

cm 1 2 3 4 5 6 7 8 9 10 11 12 13 14 15 16



De Soutter® Sterile Packed Blades

Part No.	Useable Length	Blade Width	Tooth Pitch	Blade Thickness	Cut Thickness
----------	----------------	-------------	-------------	-----------------	---------------

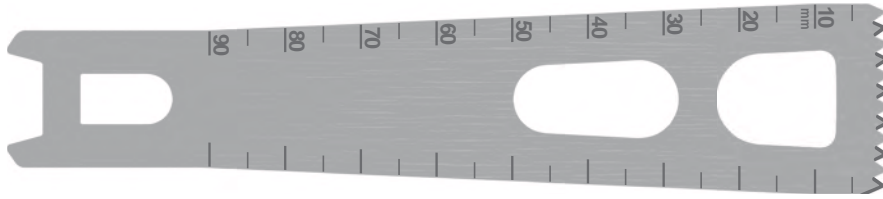

S89-6673	90	25	2.1	0.97	0.97
S89-6675	90	25	2.1	1.19	1.19
S89-6676	90	25	2.1	1.27	1.27
S89-6677	90	25	2.1	1.37	1.37
S89-6678	90	25	2.1	1.47	1.47

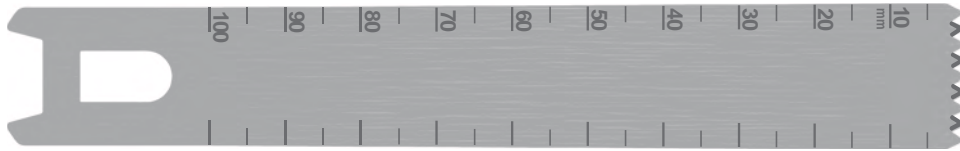

S89-6755	100	19	2.1	1.19	1.19
S89-6756	100	19	2.1	1.27	1.27
S89-6757	100	19	2.1	1.37	1.37

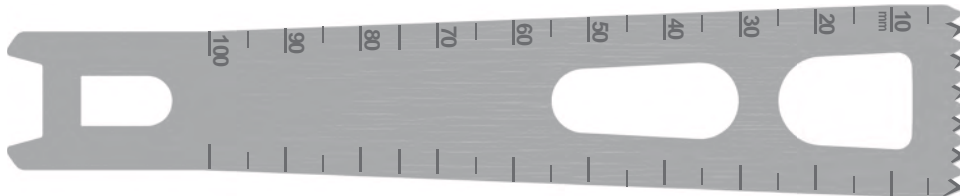

S89-6773	100	25	2.1	0.97	0.97
S89-6776	100	25	2.1	1.27	1.27

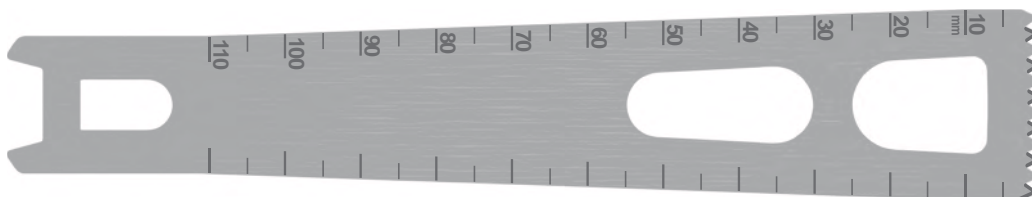

S89-6873	110	25	2.1	1.00	1.00
-----------------	-----	----	-----	------	------

All blades shown actual size (1:1). All measurements in mm.



De Soutter® Sterile Packed Blades

S89

Part No.	Useable Length	Blade Width	Tooth Pitch	Blade Thickness	Cut Thickness
----------	----------------	-------------	-------------	-----------------	---------------



S89-7575	75	25	2.0	1.19	1.19
-----------------	----	----	-----	------	------



S89-7633	90	13	2.0	0.97	0.97
S89-7636	90	13	2.0	1.27	1.27

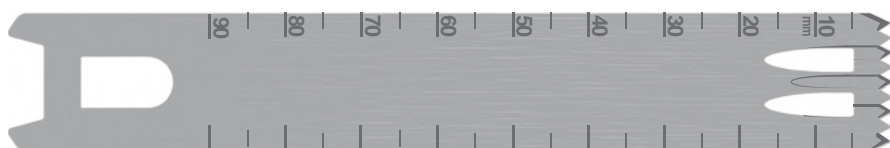

S89-7646	90	18	2.0	1.27	1.27
S89-7647	90	18	2.0	1.37	1.37



S89-7673	90	25	2.0	0.97	0.97
S89-7675	90	25	2.0	1.19	1.19
S89-7676	90	25	2.0	1.27	1.27
S89-7677	90	25	2.0	1.37	1.37

All blades shown actual size (1:1). All measurements in mm.

cm 1 2 3 4 5 6 7 8 9 10 11 12 13 14 15 16



De Soutter® Sterile Packed Blades

Part No.	Useable Length	Blade Width	Tooth Pitch	Blade Thickness	Cut Thickness
----------	----------------	-------------	-------------	-----------------	---------------

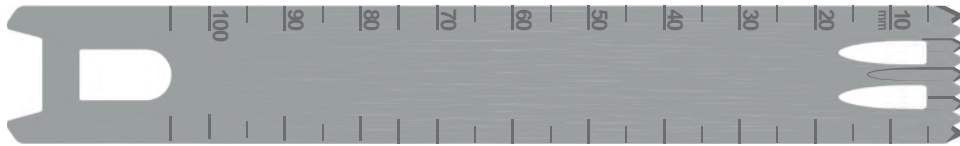

S89-7746	100	18	2.0	1.27	1.27
-----------------	-----	----	-----	------	------

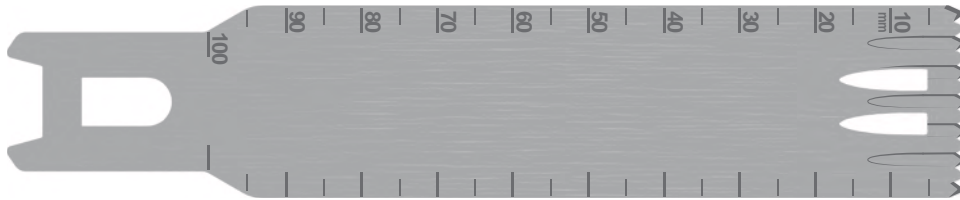

S89-7776	100	25	2.0	1.27	1.27
-----------------	-----	----	-----	------	------



S89-9536	75	13	2.1	1.27	1.27
-----------------	----	----	-----	------	------

S89-9537	75	13	2.1	1.37	1.37
-----------------	----	----	-----	------	------



S89-9656	90	19	2.1	1.27	1.27
-----------------	----	----	-----	------	------







S89-9657	90	19	2.1	1.37	1.37
-----------------	----	----	-----	------	------

All blades shown actual size (1:1). All measurements in mm.



De Soutter® Sterile Packed Blades

S92

Part No.	Useable Length	Blade Width	Tooth Pitch	Blade Thickness	Cut Thickness
 S92-120	17	4	-	-	0.51
 S92-121	21	7	-	-	0.51
 S92-122	5	8	-	-	0.51
 S92-123	9	10	-	-	0.51
 S92-124	14	12	-	-	0.51
 S92-125	21	12	-	-	0.51
 S92-126	30	12	-	-	0.51

All blades shown actual size (1:1). All measurements in mm.

cm 1 2 3 4 5 6 7 8 9 10 11 12 13 14 15 16

De Soutter® Sterile Packed Blades

Part No.	Useable Length	Blade Width	Tooth Pitch	Blade Thickness	Cut Thickness
----------	----------------	-------------	-------------	-----------------	---------------



S92-127	15	4	-	-	0.51
----------------	----	---	---	---	------



S92-132	12	13	-	-	0.51
----------------	----	----	---	---	------



S92-133	11	5.5	-	-	0.51
----------------	----	-----	---	---	------



S92-134	28	6	-	-	0.51
----------------	----	---	---	---	------

All blades shown actual size (1:1). All measurements in mm.



De Soutter® Sterile Packed Blades

S92

Part No.	Useable Length	Diameter	Tooth Pitch	Blade Thickness	Cut Thickness
----------	----------------	----------	-------------	-----------------	---------------

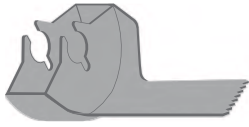

S92-137	12	9	-	-	0.51
----------------	----	---	---	---	------

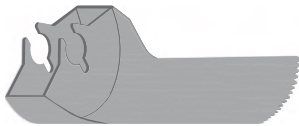

S92-138	25	13.5	-	-	0.51
----------------	----	------	---	---	------







S92-139	30	27	-	-	0.51
----------------	----	----	---	---	------

All blades shown actual size (1:1). All measurements in mm.



De Soutter® Sterile Packed Blades

Part No.	Useable Length	Blade Height	Tooth Pitch	Blade Thickness	Cut Thickness	Shank Type
						
S92-140	12	10	-	-	0.66	FLAT
						
S92-141	10	6	-	-	0.66	FLAT
						
S92-145	25	8	-	-	0.66	FLAT
						
S92-148	40	9	-	-	0.66	FLAT

All blades shown actual size (1:1). All measurements in mm.



De Soutter® Sterile Packed Blades

Part No.	Useable Length	Blade Height	Tooth Pitch	Blade Thickness	Cut Thickness	Shank Type
						
S92-151	15	6	-	-	0.66	ROUND
						
S92-152	32	6	-	-	0.66	ROUND
						
S92-154	26	9	-	-	0.66	ROUND
						
S92-156	17	6	-	-	0.66	ROUND
						
S92-157	7	8	-	-	0.81	ROUND
						
S92-158	16	5	-	-	0.94	ROUND
						
S92-159	25	7	-	-	0.94	ROUND
						
S92-160	25	7	-	-	0.94	ROUND

All blades shown actual size (1:1). All measurements in mm.

cm 1 2 3 4 5 6 7 8 9 10 11 12 13 14 15 16





De Soutter® Sterile Packed Blades

Part No.	Useable Length	Blade Height	Tooth Pitch	Blade Thickness	Cut Thickness	Shank Type
----------	----------------	--------------	-------------	-----------------	---------------	------------



S92-164	12	5.5	-	-	3.00	ROUND
----------------	----	-----	---	---	------	-------









S92-165	14	7	-	-	3.00	ROUND
----------------	----	---	---	---	------	-------

All blades shown actual size (1:1). All measurements in mm.



De Soutter® Sterile Packed Blades

S92





Part No.	Useable Length	Blade Width	Tooth Pitch	Blade Thickness	Cut Thickness
	17	4	-	-	0.66
S92-220					
	21	7	-	-	0.66
S92-221					
	5	8	-	-	0.66
S92-222					
	9	10	-	-	0.66
S92-223					
	12	14	-	-	0.66
S92-224					
	21	12	-	-	0.66
S92-225					
	30	12	-	-	0.66
S92-226					

All blades shown actual size (1:1). All measurements in mm.

cm 1 2 3 4 5 6 7 8 9 10 11 12 13 14 15 16



De Soutter® Sterile Packed Blades

Part No.	Useable Length	Blade Width	Tooth Pitch	Blade Thickness	Cut Thickness
					
S92-229	21	8	-	-	0.66
					
S92-234	28	6	-	-	0.66
					
S92-235	27	8.5	-	-	0.66
					
S92-236	32	8	-	-	0.66
					
S92-263	18.5	10	-	-	0.66

All blades shown actual size (1:1). All measurements in mm.



Dermatome

Dermatome Blades



S11

GD-113

All blades shown actual size (1:1). All measurements in mm



Dermatome

Part No.	Original Manufacturer Part No.	Blade Thickness	Cut Thickness	Tooth Pitch	Useable Length	Blade Width
----------	--------------------------------	-----------------	---------------	-------------	----------------	-------------



S11-102	-	0.23	-	-	18	52
----------------	---	------	---	---	----	----

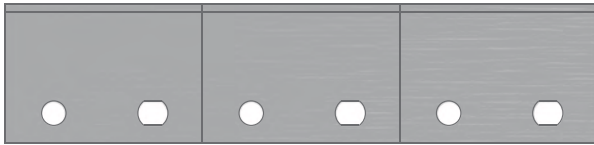

S11-103	-	0.23	-	-	18	78
----------------	---	------	---	---	----	----

All blades shown actual size (1:1). All measurements in mm



Drills / K Wires

Drills



D50

All Straight-Shank (Jacobs) Drills



D55

A.O. ® / Synthes® Drills



D56

Radiolucent



D57

Cannulated

K-Wires



K91

Passing Pin



K92

Double Trocar



K93

K Wires with Guides



K94

Single Trocar



K95

Single Trocar Partially Threaded



K96

Double Trocar Fully Threaded

All measurements in mm.

cm 1 2 3 4 5 6 7 8 9 10 11 12 13 14 15 16



Drills

Part No.	Diameter (mm)	Overall Length (mm)	Flute Length (mm)
----------	---------------	---------------------	-------------------



D50-100	1.5	70	22
D50-101	2.0	85	50
D50-102	2.5	95	50
D50-103	2.7	85	50
D50-104	3.2	130	50
D50-105	3.2	180	50
D50-106	3.5	95	50
D50-107	3.5	180	50
D50-108	4.0	156	50
D50-109	4.5	156	50
D50-110	4.5	180	50
D50-111	4.8	127	50
D50-112	5.0	180	50

All measurements in mm.



Drills

D55

Part No.	Equivalent AO Part No.	Diameter (mm)	Overall Length (mm)	Flute Length (mm)
----------	------------------------	---------------	---------------------	-------------------



D55-100	310.11	1.1	60	20
D55-101	310.15	1.5	85	30
D55-102	310.16	1.5	110	30
D55-103	310.19	2.0	100	50
D55-104	310.21	2.0	125	50
D55-105	310.25	2.5	110	50
D55-106	-	2.5	180	50
D55-107	310.26	2.7	100	50
D55-108	310.28	2.7	125	50
D55-109	310.31	3.2	145	50
D55-110	310.29	3.2	195	50
D55-111	310.35	3.5	110	50
D55-112	310.37	3.5	195	50
D55-113	310.44	4.5	145	50
D55-114	-	4.5	195	50
D55-115	-	6.0	195	50

All measurements in mm.

cm 1 2 3 4 5 6 7 8 9 10 11 12 13 14 15 16



Radiolucent Drills

Part No.	Equivalent AO Part No.	Diameter (mm)	Overall Length (mm)	Flute Length (mm)
----------	------------------------	---------------	---------------------	-------------------



D56-411	511.411	2.0	148	30
D56-412	511.412	2.5	148	30
D56-413	511.413	2.7	148	30
D56-414	511.414	3.2	148	30
D56-415	511.415	3.5	148	30
D56-416	511.416	3.6	148	30
D56-417	511.417	4.0	148	30
D56-418	511.418	4.5	148	30

All measurements in mm.

in 1 2 3 4 5 6

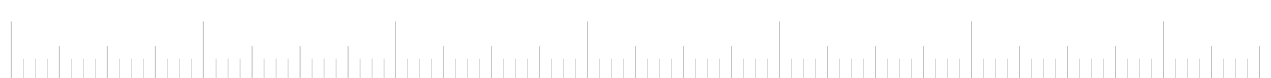

Cannulated Drills

Part No.	Equivalent Smith & Nephew Part No.	Diameter (mm)	Overall Length (mm)	Flute Length (mm)	Type
D57-450	7207315	4.5	204	10	Standard



D57

Drills / K Wires

All measurements in mm.



S10-5



Passing Pin



Part No.	Equivalent Smith & Nephew Part No.	Diameter (mm)	Overall Length (mm)	Flute Length (mm)
K91-247	7207220	2.4	385	-

All measurements in mm.

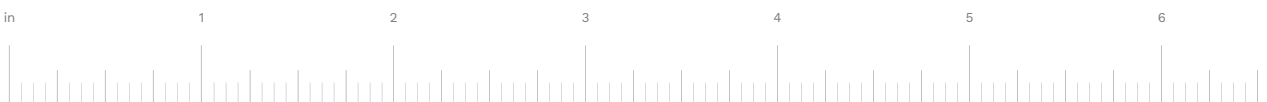

K91

Drills / K Wires

S10-6

K Wire - Double Trocar



K92

Diameter (mm)	Length (mm)					
	75	100	125	150	200	230
0.6	-	K92-064	-	-	-	-
0.7	-	-	-	K92-076	-	-
0.8	K92-083	-	K92-085	-	-	-
0.9	K92-093	K92-094	K92-095	K92-096	-	K92-099
1.0	K92-103	K92-104	-	K92-106	-	-
1.1	K92-113	K92-114	K92-115	K92-116	-	K92-119
1.2	K92-123	K92-124	K92-125	K92-126	-	-
1.25	-	-	K92-135	K92-136	-	-
1.4	-	K92-144	K92-145	K92-146	K92-148	-
1.6	K92-163	K92-164	K92-165	K92-166	K92-168	K92-169
1.8	-	-	-	K92-186	K92-188	-
2.0	-	K92-204	K92-205	K92-206	K92-208	K92-209

All measurements in mm.

cm 1 2 3 4 5 6 7 8 9 10 11 12 13 14 15 16



K Wires with Guides

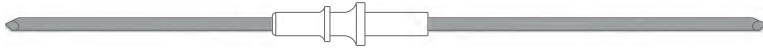

Part No.	Diameter (mm)	Overall Length (mm)
K93-064	0.6	100
K93-076	0.7	150
K93-096	0.9	150
K93-116	1.1	150
K93-166	1.6	150

All measurements in mm.

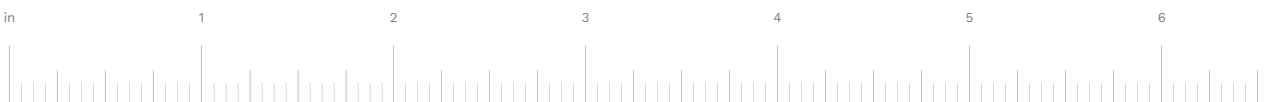

K Wire - Single Trocar



Diameter (mm)	Length (mm)				
	75	100	150	200	230
0.8	K94-083	-	-	-	-
0.9	K94-093	-	K94-096	-	K94-099
1.0	K94-103	K94-104	K94-106	-	-
1.1	-	K94-114	K94-116	-	K94-119
1.25	-	-	K94-136	K94-138	-
1.4	-	-	K94-146	-	-
1.6	-	-	K94-166	K94-168	K94-169
2.0	-	-	K94-206	K94-208	K94-209
2.5	-	-	K94-256	-	K94-259

K94

Sterile Packed Wire Guides



Part No.	Diameter (mm)
W92-060	0.6
W92-070	0.7
W92-090	0.9
W92-110	1.1
W92-160	1.6

All measurements in mm.

cm 1 2 3 4 5 6 7 8 9 10 11 12 13 14 15 16





K Wire - Single Trocar Partially Threaded



Diameter (mm)	Threaded Length (mm)	Length (mm)			
		100	150	200	230
1.5	5	K95-154	-	-	-
1.6	5	-	K95-166	-	K95-169
1.8	5	-	K95-186	-	K95-189
2.0	5	-	K95-206	K95-208	K95-209
2.4	10	-	-	K95-248	K95-249
2.8	10	-	-	-	K95-289

All measurements in mm.



K95

Drills / K Wires

S10-10

K Wire - Double Trocar Fully Threaded



Part No.	Diameter (mm)	Length (mm)
K96-124	1.2	100
K96-154	1.5	100
K96-189	1.8	230
K96-209	2.0	230
K96-249	2.4	230

K96

Drills / K Wires

All measurements in mm.



Reference

Conmed Linvatec® / Hall® Sterile Packed Compatible Blades

OEM Part No.	Part No.
5023-118	S18-118
5023-130	S18-130
5023-131	S18-131
5023-132	S18-132
5023-133	S18-133
5023-136	S18-136
5023-137	S18-137
5023-138	S18-138
5023-139	S18-139
5023-140	S18-140
5023-141	S18-141
5023-142	S18-142
5023-143	S18-143
5023-144	S18-144
5023-160	S18-160
5023-161	S18-161
5023-162	S18-162
5023-163	S18-163
5023-164	S18-164
5023-165	S18-165
5023-166	S18-166
5023-169	S18-173
5052-173	S22-273
5052-258	S22-058
5052-259	S22-059
5052-260	S22-060
5052-261	S22-061
5053-054	S22-054
5053-220	S22-020
5053-221	S22-021
5059-532	S22-032
5071-133	S15-133
5071-134	S15-134
5071-135	S15-135
5071-141	S15-205
5071-142	S15-206
5071-143	S15-200
5071-145	S15-105
5071-161	S15-561
5071-187	S15-203
5071-188	S15-204
5071-201	S15-201
5071-300	S15-6652
5071-301	S15-6653

OEM Part No.	Part No.
5071-303	S15-6655
5071-304	S15-6656
5071-305	S15-6657
5071-306	S15-6658
5071-320	S15-6672
5071-321	S15-6673
5071-323	S15-6675
5071-324	S15-6676
5071-325	S15-6677
5071-326	S15-6678
5071-340	S15-6632
5071-341	S15-6633
5071-343	S15-6635
5071-344	S15-6636
5071-529	S15-6756
5071-552	S15-103
5071-553	S15-102
5071-554	S15-207
5071-571	S15-171
5071-582	S15-220
T130-089-90	S15-6632
T130-100-90	S15-6633
T130-119-90	S15-6635
T130-127-90	S15-6636
T190-089-90	S15-6652
T190-100-90	S15-6653
T190-119-05	S15-6755
T190-119-90	S15-6655
T190-127-05	S15-6756
T190-127-90	S15-6656
T190-137-90	S15-6657
T190-147-90	S15-6658
T250-089-90	S15-6672
T250-100-90	S15-6673
T250-119-90	S15-6675
T250-127-90	S15-6676
T250-137-90	S15-6677
T250-147-90	S15-6678
V130-089-90	S15-6632
V130-100-90	S15-6633
V130-119-90	S15-6635
V130-127-90	S15-6636
V190-089-90	S15-6652
V190-100-90	S15-6653



Reference

Conmed Linvatec® / Hall® Sterile Packed Compatible Blades

OEM Part No.	Part No.
V190-119-05	S15-6755
V190-119-90	S15-6655
V190-127-05	S15-6756
V190-127-90	S15-6656
V190-137-90	S15-6657
V190-147-90	S15-6658
V250-089-90	S15-6672
V250-100-90	S15-6673
V250-119-90	S15-6675
V250-127-90	S15-6676
V250-137-90	S15-6677
V250-147-90	S15-6678

Reference

Aesculap® Sterile Packed Compatible Blades

OEM Part No.	Part No.
GC208R	S28-1140
GC209R	S28-1221
GC216R	S28-1341
GC244R	S28-536
GC296SU	S28-526
GC624R	S25-624
GC761R	S25-761
GC768R	S25-768
GC770R	S25-273
GE234SU	S28-6632
GE236SU	S28-6636
GE238SU	S28-6652
GE239SU	S28-533
GE240SU	S28-6655
GE241SU	S28-6656
GE244SU	S28-6663
GE245SU	S28-6665
GE246SU	S28-6666
GE247SU	S28-6667



Reference

Synthes® Sterile Packed Compatible Blades

OEM Part No.	Part No.
03.000.300S	S42-300
03.000.301S	S42-301
03.000.302S	S42-302
03.000.303S	S42-303
03.000.304S	S42-304
03.000.305S	S42-305
03.000.306S	S42-306
03.000.307S	S42-307
03.000.308S	S42-308
03.000.309S	S42-309
03.000.310S	S42-310
03.000.314S	S42-314
05.002.003S	S40-513
05.002.103S	S40-516
05.002.405S	S40-006
05.003.100S	S40-201
05.003.106S	S40-007
05.003.112S	S40-004
05.003.117S	S40-6657
05.003.130S	S40-008
05.003.132S	S40-005
05.003.134S	S40-6675
05.003.137S	S40-6677
511.905S	S48-905
511.912S	S48-912
519.100S	S40-010
519.150S	S40-015
519.170S	S40-017
519.190S	S40-019
519.200S	S40-020
519.210S	S40-021
519.230S	S40-023
519.250S	S40-025
532.041S	S44-041
532.042S	S44-042
532.043S	S44-043
532.044S	S44-044
532.045S	S44-045
532.046S	S44-046
532.047S	S44-047
532.048S	S44-048
532.061S	S44-061
532.062S	S44-062
532.063S	S44-063

OEM Part No.	Part No.
532.064S	S44-064
532.065S	S44-065
532.066S	S44-066
532.067S	S44-067

Reference

Stryker® Sterile Packed Compatible Blades

OEM Part No.	Part No.
2108-100	S56-100
2108-102	S56-102
2108-115	S56-115
2108-125	S56-125
2108-131	S56-131
2108-137	S56-137
2108-140	S56-141
2108-145	S56-145
2108-148	S56-148
2108-151	S56-151
2108-156	S56-156
2108-182	S56-182
2108-183	S56-183
2108-185	S56-185
2108-189	S56-189
2108-328	S56-328
2108-382-2	S56-9657
2108-382-3	S56-9656
2296-3-101	S59-101
2296-3-102	S59-102
2296-3-103	S59-103
2296-3-104	S59-104
2296-3-105	S59-105
2296-3-106	S59-106
2296-3-108	S59-108
2296-3-111	S59-111
2296-3-114	S59-114
2296-3-115	S59-115
2296-3-125	S59-125
2296-3-206	S59-206
2296-3-212	S59-212
2296-3-225	S59-225
2296-3-410	S59-410
2296-3-412	S59-412
2296-3-413	S59-413
2296-3-414	S59-414
2296-33-101	S59-601
2296-33-102	S59-602
2296-33-103	S59-603
2296-33-104	S59-604
2296-33-105	S59-605
2296-33-106	S59-606
2296-33-108	S59-608
2296-33-111	S59-611

OEM Part No.	Part No.
2296-33-114	S59-614
2296-33-115	S59-615
2296-33-125	S59-625
2296-33-206	S59-706
2296-33-212	S59-712
2296-33-225	S59-725
2296-33-410	S59-910
2296-33-411	S59-911
2296-33-412	S59-912
2296-33-413	S59-913
2296-33-414	S59-914
2296-33-51	S59-951
277-96-275	S57-275
277-96-277	S57-277
277-96-325	S57-325
298-97-100	S57-100
4111-089-090	S56-407
4111-127-090	S56-408
4118-089-090	S56-401
4118-127-090	S56-402
4125-089-075	S56-405
4125-089-090	S56-409
4125-127-090	S56-403
4125-127-100	S56-406
4125-135-090	S56-404
5400-003-254S1	S59-7985
5400-3-115	S59-7624
6113-089-090	S56-6632
6113-127-090	S56-502
6118-119-090	S56-6655
6118-127-090	S56-6656
6125-089-075	S56-6572
6125-119-090	S56-515
6125-127-090	S56-518
6125-137-090	S56-529
6125-147-090	S56-528



Reference

Zimmer® Sterile Packed Compatible Blades

OEM Part No.	Part No.
12-0901-19U-R1	S64-358
13-0760-89U-R1	S64-375

Reference

Other Sterile Packed Compatible Blades

OEM Part No.	Part No.
1200-001	S72-001
1200-005	S72-005
1200-006	S72-006
1200-007	S72-007
1200-009	S72-009
1200-013	S72-013
1400-001	S77-001
1400-002	S77-002
7205804	S71-804
7205806	S71-806
AR-300-040S	S74-040
AR-300-041S	S74-041
AR-300-043S	S74-043
AR-600-001S	S75-6636
AR-600-002S	S75-6656
AR-600-005S	S75-6676
ZO-7052	S78-052
ZO-7123	S78-123
ZO-7145	S78-145
ZO-7151	S78-051
ZO-7156	S78-156
ZO-7163	S78-3677
ZO-7172	S78-172
ZO-7274	S78-274
ZO-7654	S78-654
ZO-7682	S78-682
ZO-7685	S78-685

Reference

Index

Stericut Ref.	Page No.
D50-100	S10-2
D50-101	S10-2
D50-102	S10-2
D50-103	S10-2
D50-104	S10-2
D50-105	S10-2
D50-106	S10-2
D50-107	S10-2
D50-108	S10-2
D50-109	S10-2
D50-110	S10-2
D50-111	S10-2
D50-112	S10-2
D55-100	S10-3
D55-101	S10-3
D55-102	S10-3
D55-103	S10-3
D55-104	S10-3
D55-105	S10-3
D55-106	S10-3
D55-107	S10-3
D55-108	S10-3
D55-109	S10-3
D55-110	S10-3
D55-111	S10-3
D55-112	S10-3
D55-113	S10-3
D55-114	S10-3
D55-115	S10-3
D56-411	S10-4
D56-412	S10-4
D56-413	S10-4
D56-414	S10-4
D56-415	S10-4
D56-416	S10-4
D56-417	S10-4
D56-418	S10-4
D57-450	S10-5
K91-247	S10-6
K92-064	S10-7
K92-076	S10-7
K92-083	S10-7
K92-085	S10-7
K92-093	S10-7
K92-094	S10-7
K92-095	S10-7
K92-096	S10-7
K92-099	S10-7
K92-103	S10-7
K92-104	S10-7
K92-106	S10-7
K92-113	S10-7

Stericut Ref.	Page No.
K92-114	S10-7
K92-115	S10-7
K92-116	S10-7
K92-119	S10-7
K92-123	S10-7
K92-124	S10-7
K92-125	S10-7
K92-126	S10-7
K92-135	S10-7
K92-136	S10-7
K92-144	S10-7
K92-145	S10-7
K92-146	S10-7
K92-148	S10-7
K92-163	S10-7
K92-164	S10-7
K92-165	S10-7
K92-166	S10-7
K92-168	S10-7
K92-169	S10-7
K92-186	S10-7
K92-188	S10-7
K92-204	S10-7
K92-205	S10-7
K92-206	S10-7
K92-208	S10-7
K92-209	S10-7
K93-064	S10-8
K93-076	S10-8
K93-096	S10-8
K93-116	S10-8
K93-166	S10-8
K94-083	S10-9
K94-093	S10-9
K94-096	S10-9
K94-099	S10-9
K94-103	S10-9
K94-104	S10-9
K94-106	S10-9
K94-114	S10-9
K94-116	S10-9
K94-119	S10-9
K94-136	S10-9
K94-138	S10-9
K94-146	S10-9
K94-166	S10-9
K94-168	S10-9
K94-169	S10-9
K94-206	S10-9
K94-208	S10-9
K94-209	S10-9
K94-256	S10-9

Stericut Ref.	Page No.
K94-259	S10-9
K95-154	S10-10
K95-166	S10-10
K95-169	S10-10
K95-186	S10-10
K95-189	S10-10
K95-206	S10-10
K95-208	S10-10
K95-209	S10-10
K95-248	S10-10
K95-249	S10-10
K95-289	S10-10
K96-124	S10-11
K96-154	S10-11
K96-189	S10-11
K96-209	S10-11
K96-249	S10-11
S01-001	S1-2
S02-001	S2-2
S04-001	S4-2
S05-001	S5-2
S08-001	S8-3
S08-002	S8-4
S08-003	S8-5
S11-102	S9-2
S11-103	S9-2
S15-102	S1-3
S15-103	S1-3
S15-105	S1-3
S15-125	S1-3
S15-133	S1-4
S15-134	S1-4
S15-135	S1-4
S15-171	S1-4
S15-200	S1-4
S15-201	S1-5
S15-202	S1-5
S15-203	S1-5
S15-204	S1-5
S15-205	S1-5
S15-206	S1-6
S15-207	S1-6
S15-209	S1-6
S15-215	S1-6
S15-220	S1-6
S15-256	S1-7
S15-501	S1-7
S15-503	S1-7
S15-506	S1-7
S15-508	S1-8
S15-511	S1-8
S15-513	S1-8



Reference

Index

Stericut Ref.	Page No.
S15-516	S1-8
S15-523	S1-9
S15-524	S1-9
S15-527	S1-9
S15-553	S1-9
S15-556	S1-9
S15-561	S1-10
S15-562	S1-2, S1-10
S15-6632	S1-11
S15-6633	S1-11
S15-6635	S1-11
S15-6636	S1-11
S15-6652	S1-11
S15-6653	S1-11
S15-6655	S1-11
S15-6656	S1-11
S15-6657	S1-11
S15-6658	S1-11
S15-6672	S1-12
S15-6673	S1-12
S15-6675	S1-12
S15-6676	S1-12
S15-6677	S1-12
S15-6678	S1-12
S15-6755	S1-12
S15-6756	S1-12
S18-104	S1-13
S18-118	S1-13
S18-130	S1-13
S18-131	S1-13
S18-132	S1-13
S18-133	S1-14
S18-136	S1-14
S18-137	S1-14
S18-138	S1-14
S18-139	S1-14
S18-140	S1-15
S18-141	S1-15
S18-142	S1-15
S18-143	S1-15
S18-144	S1-15
S18-160	S1-16
S18-161	S1-16
S18-162	S1-16
S18-163	S1-16
S18-164	S1-16
S18-165	S1-16
S18-166	S1-16
S18-173	S1-17
S22-020	S1-18
S22-021	S1-18

Stericut Ref.	Page No.
S22-032	S1-19
S22-054	S1-20
S22-058	S1-21, S8-6
S22-059	S1-21, S8-6
S22-060	S1-21, S8-6
S22-061	S1-21, S8-6
S22-063	S1-21, S8-6
S22-273	S1-21, S8-6
S22-275	S1-21, S8-6
S22-364	S1-2, S1-22, S8-3, S8-7
S22-381	S1-2, S1-23, S8-3, S8-8
S25-273	S2-3
S25-364	S2-2, S2-3
S25-381	S2-2, S2-4
S25-624	S2-5
S25-761	S2-5
S25-768	S2-6
S28-206	S2-7
S28-256	S2-7
S28-502	S2-7
S28-511	S2-7
S28-513	S2-7
S28-526	S2-8
S28-527	S2-8
S28-528	S2-8
S28-533	S2-8
S28-536	S2-8
S28-1140	S2-9
S28-1211	S2-9
S28-1221	S2-9
S28-1341	S2-9
S28-6632	S2-2, S2-9
S28-6636	S2-9
S28-6652	S2-10
S28-6655	S2-10
S28-6656	S2-10
S28-6663	S2-10
S28-6665	S2-10

Stericut Ref.	Page No.
S28-6666	S2-10
S28-6667	S2-10
S40-004	S4-3, S6-2
S40-005	S4-3, S6-2
S40-006	S4-3, S6-2
S40-007	S4-3, S6-2
S40-008	S4-3, S6-2
S40-010	S4-4, S6-3
S40-015	S4-4, S6-3
S40-017	S4-4, S6-3
S40-019	S4-4, S6-3
S40-020	S4-5, S6-4
S40-021	S4-5, S6-4
S40-023	S4-5, S6-4
S40-025	S4-5, S6-4
S40-057	S4-5, S6-4
S40-200	S4-6, S6-5
S40-201	S4-6, S6-5
S40-205	S4-6, S6-5
S40-206	S4-6, S6-5
S40-209	S4-6, S6-5
S40-513	S4-7, S6-6
S40-516	S4-7, S6-6
S40-518	S4-7, S6-6
S40-528	S4-7, S6-6
S40-530	S4-7, S6-6
S40-561	S4-2, S4-8, S6-7
S40-571	S4-8, S6-7

Reference

Index

Stericut Ref.	Page No.
S40-575	S4-8, S6-7
S40-6657	S4-9, S6-8
S40-6675	S4-9, S6-8
S40-6677	S4-9, S6-8
S42-300	S4-10
S42-301	S4-10
S42-302	S4-10
S42-303	S4-10
S42-304	S4-10
S42-305	S4-10
S42-306	S4-11
S42-307	S4-11
S42-308	S4-11
S42-309	S4-11
S42-310	S4-11
S42-314	S4-11
S44-041	S4-12
S44-042	S4-12
S44-043	S4-12
S44-044	S4-12
S44-045	S4-12
S44-046	S4-12
S44-047	S4-13
S44-048	S4-13
S44-061	S4-13
S44-062	S4-13
S44-063	S4-13
S44-064	S4-13
S44-065	S4-14
S44-066	S4-14
S44-067	S4-14
S48-364	S4-2, S4-15
S48-381	S4-2, S4-16
S48-905	S4-17
S48-912	S4-17
S48-920	S4-17
S56-100	S5-3
S56-102	S5-3
S56-115	S5-3
S56-125	S5-3
S56-131	S5-4
S56-137	S5-4
S56-140	S5-4
S56-141	S5-5
S56-145	S5-5
S56-148	S5-5
S56-151	S5-5

Stericut Ref.	Page No.
S56-156	S5-5
S56-177	S5-6
S56-182	S5-6
S56-183	S5-6
S56-185	S5-6
S56-187	S5-6
S56-189	S5-7
S56-218	S5-7
S56-328	S5-7
S56-401	S5-7
S56-402	S5-7
S56-403	S5-8
S56-404	S5-8
S56-405	S5-8
S56-406	S5-8
S56-407	S5-8
S56-408	S5-9
S56-409	S5-9
S56-502	S5-9
S56-505	S5-9
S56-507	S5-9
S56-510	S5-10
S56-515	S5-10
S56-518	S5-10
S56-522	S5-10
S56-528	S5-10
S56-529	S5-11
S56-561	S5-2, S5-11
S56-585	S5-11
S56-6572	S5-12
S56-6575	S5-12
S56-6632	S5-12
S56-6655	S5-12
S56-6656	S5-12
S56-9656	S5-12
S56-9657	S5-12
S57-100	S5-13
S57-275	S5-14
S57-277	S5-14
S57-325	S5-14
S57-364	S5-2, S5-14
S57-381	S5-2, S5-15
S59-101	S5-16
S59-102	S5-16
S59-103	S5-16
S59-104	S5-16
S59-105	S5-16
S59-106	S5-17
S59-108	S5-17

Stericut Ref.	Page No.
S59-111	S5-17
S59-114	S5-17
S59-115	S5-17
S59-125	S5-18
S59-206	S5-18
S59-212	S5-18
S59-225	S5-18
S59-410	S5-18
S59-412	S5-19
S59-413	S5-19
S59-414	S5-19
S59-601	S5-16
S59-602	S5-16
S59-603	S5-16
S59-604	S5-16
S59-605	S5-16
S59-606	S5-17
S59-608	S5-17
S59-611	S5-17
S59-614	S5-17
S59-615	S5-17
S59-625	S5-18
S59-706	S5-18
S59-712	S5-18
S59-725	S5-18
S59-910	S5-18
S59-911	S5-19
S59-912	S5-19
S59-913	S5-19
S59-914	S5-19
S59-951	S5-19
S59-7624	S5-20
S59-7985	S5-20
S59-9268	S5-20
S64-358	S6-9
S64-359	S6-9
S64-361	S6-9
S64-364	S6-9
S64-373	S6-9
S64-375	S6-9
S71-804	S7-3
S71-806	S7-3
S72-001	S7-4
S72-005	S7-4
S72-006	S7-4
S72-007	S7-4
S72-009	S7-4
S72-013	S7-4
S74-040	S7-10
S74-041	S7-10
S74-043	S7-10
S75-2483	S7-11



Reference

Index

Stericut Ref.	Page No.
S75-6636	S7-11
S75-6656	S7-11
S75-6676	S7-11
S77-001	S7-5
S77-002	S7-5
S78-051	S7-6
S78-052	S7-6
S78-123	S7-6
S78-145	S7-6
S78-156	S7-7
S78-172	S7-7
S78-206	S7-7
S78-274	S7-7
S78-556	S7-8
S78-654	S7-8
S78-682	S7-8
S78-685	S7-8
S78-3677	S7-9
S81-101	S8-9
S81-102	S8-9
S81-105	S8-10
S81-106	S8-10
S81-200	S8-11
S81-201	S8-11
S81-202	S8-12
S82-100	S8-13
S82-101	S8-13
S82-102	S8-13
S82-103	S8-13
S82-104	S8-14
S83-0325	S8-15
S83-0405	S8-15
S83-0428	S8-15
S83-0605	S8-15
S83-1155	S8-15
S83-1428	S8-15
S83-1528	S8-15
S83-4425	S8-15
S84-358	S8-16
S84-359	S8-16
S84-360	S8-16
S84-361	S8-16
S84-363	S8-16
S84-364	S8-4, S8-5, S8-16
S84-373	S8-17
S84-375	S8-17
S84-381	S8-4, S8-5, S8-18
S84-400	S8-19

Stericut Ref.	Page No.
S84-401	S8-19
S84-402	S8-19
S85-100	S8-20
S85-101	S8-20
S85-102	S8-20
S85-103	S8-20
S85-104	S8-20
S85-105	S8-20
S85-106	S8-21
S85-107	S8-21
S85-108	S8-21
S85-109	S8-21
S85-110	S8-21
S85-111	S8-21
S85-115	S8-22
S85-118	S8-22
S85-124	S8-22
S85-125	S8-22
S85-150	S8-22
S85-151	S8-22
S85-152	S8-23
S85-153	S8-23
S85-154	S8-23
S85-156	S8-23
S85-157	S8-23
S85-158	S8-23
S85-159	S8-24
S85-160	S8-24
S85-162	S8-24
S85-163	S8-24
S85-176	S8-24
S85-180	S8-25
S85-200	S8-25
S86-0312	S8-26
S86-0315	S8-26
S86-0322	S8-26
S86-0512	S8-26
S86-0515	S8-26
S86-0532	S8-26
S86-0534	S8-26
S86-0535	S8-26
S86-0622	S8-26
S86-0624	S8-26
S86-0632	S8-27
S86-0634	S8-27
S86-0715	S8-27
S86-0835	S8-27
S86-1225	S8-27
S86-1425	S8-27
S86-1435	S8-27
S86-1515	S8-28
S86-1535	S8-28

Stericut Ref.	Page No.
S86-1555	S8-28
S86-1632	S8-28
S86-1735	S8-28
S86-1855	S8-28
S86-3885	S8-29
S86-4835	S8-29
S86-5515	S8-29
S87-050	S8-30
S87-100	S8-30
S87-101	S8-30
S87-102	S8-30
S87-103	S8-30
S87-104	S8-31
S87-105	S8-31
S87-106	S8-31
S87-107	S8-31
S87-108	S8-32
S87-109	S8-32
S87-110	S8-32
S87-111	S8-32
S87-112	S8-33
S87-113	S8-33
S87-118	S8-34
S87-119	S8-34
S87-120	S8-35
S87-121	S8-35
S87-123	S8-36
S87-125	S8-36
S87-130	S8-36
S87-134	S8-37
S87-200	S8-37
S87-206	S8-37
S87-207	S8-37
S87-208	S8-37
S87-209	S8-38
S87-219	S8-38
S87-228	S8-38
S87-256	S8-38
S87-323	S8-39
S87-325	S8-39
S87-326	S8-39
S87-327	S8-39
S87-328	S8-39
S87-411	S8-40
S87-413	S8-40
S87-416	S8-40
S87-423	S8-40
S87-426	S8-40
S87-433	S8-41
S87-436	S8-41
S87-451	S8-41
S87-469	S8-41

Reference

Index

Stericut Ref.	Page No.
S87-500	S8-41
S87-501	S8-42
S87-502	S8-42
S87-503	S8-42
S87-505	S8-42
S87-506	S8-42
S87-508	S8-43
S87-510	S8-43
S87-511	S8-43
S87-512	S8-43
S87-513	S8-44
S87-515	S8-44
S87-516	S8-44
S87-518	S8-44
S87-521	S8-45
S87-522	S8-45
S87-523	S8-45
S87-525	S8-45
S87-526	S8-45
S87-527	S8-46
S87-528	S8-46
S87-533	S8-46
S87-536	S8-46
S87-538	S8-47
S87-543	S8-47
S87-545	S8-47
S87-547	S8-47
S87-548	S8-48
S87-549	S8-48
S87-551	S8-48
S87-553	S8-48
S87-556	S8-48
S87-561	S8-3, S8-4, S8-49
S87-563	S8-49
S87-585	S8-49
S87-595	S8-49
S87-600	S8-49
S87-5657	S8-50
S87-6638	S8-50
S88-100	S8-51
S88-101	S8-51
S88-102	S8-51
S88-103	S8-51
S88-104	S8-51
S88-105	S8-51
S88-106	S8-52
S88-107	S8-52
S88-108	S8-52
S88-109	S8-52
S88-110	S8-52

Stericut Ref.	Page No.
S88-111	S8-52
S88-113	S8-53
S88-114	S8-53
S88-115	S8-53
S88-134	S8-53
S88-138	S8-53
S88-150	S8-53
S88-151	S8-54
S88-152	S8-54
S88-153	S8-54
S88-154	S8-54
S88-156	S8-54
S88-157	S8-54
S88-158	S8-55
S88-159	S8-55
S88-160	S8-55
S88-162	S8-55
S88-180	S8-55
S88-181	S8-55
S88-470	S8-56
S88-475	S8-56
S88-476	S8-56
S88-477	S8-56
S88-908	S8-57
S88-909	S8-57
S88-918	S8-57
S88-919	S8-58
S89-1111	S8-59
S89-1211	S8-59
S89-1221	S8-59
S89-1351	S8-59
S89-1421	S8-59
S89-1440	S8-60
S89-1452	S8-60
S89-1473	S8-60
S89-1491	S8-60
S89-1522	S8-61
S89-1553	S8-61
S89-1573	S8-61
S89-1586	S8-61
S89-1676	S8-61
S89-2472	S8-62
S89-2483	S8-62
S89-2673	S8-62
S89-2676	S8-62
S89-2772	S8-62
S89-3656	S8-63
S89-3673	S8-63
S89-3675	S8-63
S89-3676	S8-63
S89-3677	S8-63
S89-3678	S8-63

Stericut Ref.	Page No.
S89-5632	S8-63
S89-5633	S8-63
S89-5636	S8-63
S89-5637	S8-63
S89-5652	S8-63
S89-5653	S8-63
S89-5655	S8-63
S89-5656	S8-63
S89-5657	S8-63
S89-5658	S8-63
S89-5672	S8-64
S89-5673	S8-64
S89-5674	S8-64
S89-5675	S8-64
S89-5676	S8-64
S89-5677	S8-64
S89-5678	S8-64
S89-5755	S8-64
S89-5756	S8-64
S89-5757	S8-64
S89-6506	S8-64
S89-6536	S8-64
S89-6556	S8-65
S89-6557	S8-65
S89-6632	S8-5, S8-65
S89-6633	S8-65
S89-6635	S8-65
S89-6636	S8-65
S89-6637	S8-65
S89-6638	S8-65
S89-6653	S8-65
S89-6655	S8-65
S89-6656	S8-65
S89-6657	S8-65
S89-6658	S8-65
S89-6673	S8-66
S89-6675	S8-66
S89-6676	S8-66
S89-6677	S8-66
S89-6678	S8-66
S89-6755	S8-66
S89-6756	S8-66
S89-6757	S8-66
S89-6773	S8-66
S89-6776	S8-66
S89-6873	S8-66
S89-7575	S8-67
S89-7633	S8-67
S89-7636	S8-67
S89-7646	S8-67
S89-7647	S8-67



Reference

Index

Stericut Ref.	Page No.
S89-7673	S8-67
S89-7675	S8-67
S89-7676	S8-67
S89-7677	S8-67
S89-7746	S8-68
S89-7776	S8-68
S89-9536	S8-68
S89-9537	S8-68
S89-9656	S8-68
S89-9657	S8-68
S92-120	S8-69
S92-121	S8-69
S92-122	S8-69
S92-123	S8-69
S92-124	S8-69
S92-125	S8-69
S92-126	S8-69
S92-127	S8-70
S92-132	S8-70
S92-133	S8-70

Stericut Ref.	Page No.
S92-134	S8-70
S92-137	S8-71
S92-138	S8-71
S92-139	S8-71
S92-140	S8-72
S92-141	S8-72
S92-145	S8-72
S92-148	S8-72
S92-151	S8-73
S92-152	S8-73
S92-154	S8-73
S92-156	S8-73
S92-157	S8-73
S92-158	S8-73
S92-159	S8-73
S92-160	S8-73
S92-164	S8-74
S92-165	S8-74
S92-220	S8-75
S92-221	S8-75

Stericut Ref.	Page No.
S92-222	S8-75
S92-223	S8-75
S92-224	S8-75
S92-225	S8-75
S92-226	S8-75
S92-229	S8-76
S92-234	S8-76
S92-235	S8-76
S92-236	S8-76
S92-263	S8-76
S95-100	S7-12
S95-101	S7-12
W92-060	S10-9
W92-070	S10-9
W92-090	S10-9
W92-110	S10-9
W92-160	S10-9

de Soutter MEDICAL

For further information on Stericut® blades and burs
please contact the address in your area.

United Kingdom (International Head Office)

De Soutter Medical Limited
Halton Brook Business Park, Weston Road
Aston Clinton, Aylesbury, Bucks HP22 5WF
Tel: +44 (0) 1296 634 000
Fax: +44 (0) 1296 634 033
Email: info@de-soutter.com

Australia

De Soutter Medical Australia Pty Ltd
2/12-14 Apollo Drive, Hallam, Victoria 3803
Tel: +61 (0) 3 9702 4441
Fax: +61 (0) 3 9702 4484
Email: australia@de-soutter.com

Austria

De Soutter Medical Austria
Zweigniederlassung Österreich
Dietrichsteingasse 10, A-3400 Klosterneuburg
Tel: +43 (0) 676 96 71 770
Fax: +43 (0) 2243 21 656
Email: austria@de-soutter.com

Belgium

De Soutter Medical Belgium
Bessemersstraat 14, 3620 Lanaken
Tel: +32 (0) 89/47 15 37
Fax: +32 (0) 89/70 12 19
Email: belgium@de-soutter.com

France

De Soutter Medical France
1 252 Avenue Parc des Expositions
33260 La Teste de Buch
Tel: +33 (0) 5 56 54 89 36
Fax: +33 (0) 9 70 61 37 60
Email: france@de-soutter.com

Germany

De Soutter Medical Germany
Bahnhofstraße 4,
D-66625 Nohfelden
Tel: +49 (0) 68 52-99 12 46
Fax: +49 (0) 68 52-99 12 47
Email: deutschland@de-soutter.com

Italy

De Soutter Medical italia
Localita' Fornace SNC
27022 Casorate Primo - PV, Italia
Tel: +39 (0) 2 9009 4098
Fax: +39 (0) 2 9009 2673
Email: italy@de-soutter.com

Netherlands

De Soutter Medical Nederland
Gelderlandhaven 2X
3433 PG Nieuwegein
Tel: +31 (0) 85 0491480
Fax: +31 (0) 85 0491489
Email: nederland@de-soutter.com

United States of America

De Soutter Medical USA, Inc.
224 Rolling Hill Road, Suite 12A
 Mooresville, NC 28117
Tel: +1 (704) 655 9040
Fax: +1 (704) 987 2035
Email: usa@de-soutter.com

